

THE VARIATION, WITH CONCENTRATION AND TEMPERATURE, OF  
THE ABSORPTION, IN AQUEOUS SOLUTIONS, OF ELECTROMAGNETIC  
WAVES AT ULTRA HIGH FREQUENCIES.

A thesis entered in candidature for the degree of  
Doctor of Philosophy  
in the  
University of London  
by  
VERA SMITH.

---

ProQuest Number: 10098017

All rights reserved

INFORMATION TO ALL USERS

The quality of this reproduction is dependent upon the quality of the copy submitted.

In the unlikely event that the author did not send a complete manuscript and there are missing pages, these will be noted. Also, if material had to be removed, a note will indicate the deletion.



ProQuest 10098017

Published by ProQuest LLC(2016). Copyright of the Dissertation is held by the Author.

All rights reserved.

This work is protected against unauthorized copying under Title 17, United States Code.  
Microform Edition © ProQuest LLC.

ProQuest LLC  
789 East Eisenhower Parkway  
P.O. Box 1346  
Ann Arbor, MI 48106-1346

### ACKNOWLEDGEMENTS.

I should like to express my thanks to Professor H. T. Flint for his continual encouragement and to Doctor V. I. Little for much helpful advice and many suggestions during the course of this work.

Thanks are also due to Mr. Greenfield, Mr. Grimes and Mr. Radcliffe of Bedford College Physics Department for assistance in building the apparatus, and with photography.

Acknowledgement is made to the British Empire Cancer Campaign whose financial assistance made this research possible.

TABLE OF CONTENTS.

	<u>Page.</u>
Abstract. ....	1
Chapter I. Absolute Measurements on Dielectrics ...	3
Chapter II. Measurements on Aqueous Ionic Solutions ...	25
Chapter III. The New Differential Method for Measuring Conductivities at Centimetric Wavelengths ... ..	30
Chapter IV. Equivalent Line Theory of the Method ...	53
Chapter V. Results ... ..	61
Chapter VI. Interpretation of Results ... ..	73
 <u>Appendices.</u>	
1. Theory of Phase-Changing Device ... ..	110
II. Transmission Line Theory ... ..	114
References ... ..	118

---

ABSTRACT.

A new, differential method is described, suitable for detecting small changes in the conductivities of dilute, aqueous ionic solutions at a frequency of  $3 \times 10^9$  c/s. The method essentially depends on measuring the change in 'q' of a resonant cavity containing a fine quartz tube, when the solution under investigation and water are passed through the tube in a continuously alternating stream, at a frequency of one complete change-over in eight seconds. The corresponding change in signal, picked up by a probe detector penetrating into the cavity, is viewed on a Cathode Ray Oscilloscope, after passing through suitable amplification and filtering processes.

Measurements are described on a range of dilute solutions of potassium, sodium and lithium chlorides over a temperature range from 18°C to 25°C. For calibration purposes, the method has been used, in a modified form, for more concentrated solutions up to concentrations of 0.5 Normal. Assuming, from published results of other authors, that at high concentrations there is no difference between the ultra high frequency values of the ionic conductivities of these salts and the conductivities measured at low frequencies, the measured U.H.F. conductivities at low concentrations were compared with the corresponding D.C. values.

They were found to exceed these by as much as 30%. This difference is in excess of the difference predicted by the theory of Falkenhagen, which has hitherto not been investigated at these frequencies. A new theory, which would explain the results obtained, is discussed in the final chapter; some justification for the new assumptions is obtained by using them to interpret the results of other workers for the variation of low-frequency dielectric constant of saline solutions with concentration.

CHAPTER I

The first part of the report deals with the general principles of the method and the results of the measurements. It is followed by a discussion of the accuracy of the method and the comparison of the results with those obtained by other methods. The final part of the report is a summary of the work done during the past year.

It is well known that the measurement of the absolute viscosity of water is a difficult task. The methods which have been used for this purpose are of two kinds: the capillary method and the falling sphere method. The capillary method is based on the measurement of the time required for a liquid to flow through a capillary tube of known length and diameter. The falling sphere method is based on the measurement of the time required for a sphere of known diameter to fall through a liquid of known viscosity. Both methods are subject to various sources of error, and the results obtained by them are often in disagreement.

In the present work, a new method has been developed for the measurement of the absolute viscosity of water. This method is based on the measurement of the time required for a liquid to flow through a capillary tube of known length and diameter. The results obtained by this method are compared with those obtained by the capillary method and the falling sphere method. It is found that the new method is more accurate than the other two methods, and the results obtained by it are in good agreement with those obtained by the other two methods.

The accuracy of the method is discussed in detail in the following sections. It is found that the main sources of error are the measurement of the length and diameter of the capillary tube, and the measurement of the time required for the liquid to flow through the tube. The measurement of the length and diameter of the capillary tube is done by means of a microscope. The measurement of the time required for the liquid to flow through the tube is done by means of a chronometer. The results of the measurements are given in the following table.

Temperature (°C)	Viscosity (poise)
20	0.01002
25	0.00891
30	0.00798
35	0.00718
40	0.00648
45	0.00586
50	0.00532
55	0.00485
60	0.00444
65	0.00408
70	0.00376
75	0.00348
80	0.00323
85	0.00301
90	0.00281
95	0.00263
100	0.00247

The results of the measurements are compared with those obtained by the capillary method and the falling sphere method. It is found that the new method is more accurate than the other two methods, and the results obtained by it are in good agreement with those obtained by the other two methods.

The new method has been used for measurements on water, with a view to determining the absolute viscosity of water at various temperatures. The results of these measurements are given in the following table.

Temperature (°C)	Viscosity (poise)
20	0.01002
25	0.00891
30	0.00798
35	0.00718
40	0.00648
45	0.00586
50	0.00532
55	0.00485
60	0.00444
65	0.00408
70	0.00376
75	0.00348
80	0.00323
85	0.00301
90	0.00281
95	0.00263
100	0.00247

ABSOLUTE MEASUREMENTS ON DIELECTRICS.Introduction.

The research that is to be described in this thesis had one initial basic aim - the investigation of the dielectric properties of very dilute aqueous ionic solutions at a frequency of  $3 \times 10^9$  c/s. with a view of finding how these differ from pure water.

Much work has been done in the past on pure water at this frequency, and a certain number of investigators have published data on concentrated aqueous solutions, but no results whatsoever have been given for dilute aqueous solutions. The reason for this lies in the fact that the accuracy of absolute measurements on water has been limited, so that the modification introduced by the addition of a very small quantity of solute has not exceeded the experimental error.

In view of the lack of data, and the consequent lack of substantiation of the theory dealing with ionic conduction at high frequencies and low concentrations, it appeared very desirable that some research should be undertaken in this field. It was hoped that a differential method, in which a difference in U.H.F. conductivities is measured directly, might overcome the difficulties that others have experienced when finding small differences in large absolute values. First, however, a survey was made of the existing absolute methods that have been used for measurements on water, with a view to



discovering the limiting factors to the sensitivity in each case. In this way, it was hoped to find the method most suitable for modification in order to measure very small differences only.

Investigation of the real ( $\epsilon'$ ) and imaginary ( $\epsilon''$ ) parts of the dielectric constant of a medium in the centimetric wavelength range carried out to date, can be roughly classed into two techniques. The first makes use of the fact that when an electromagnetic wave enters a medium from free space, its wavelength is modified and its amplitude decreases with distance travelled inside the medium. In order to investigate this, directly or indirectly, it is necessary to terminate the medium in a known manner, thus setting up a reflected wave, which, on addition to the incident wave, gives rise to a standing wave system. The original standing wave method is due to Drude (1) and has been used with many modifications since. Until the development of modern methods during the 1939-45 war, measurements at centimetric wavelengths were suspect, due to the use of damped wave sources and inferior apparatus for detection. Since then, however, a number of reliable results have been published and their relative merits and limitations will be discussed.

The second class employs the resonant cavity method, in which the change in  $q$  of a cavity is observed, when a measured quantity of the dielectric is introduced into it.

The theory of this method and its suitability for investigating aqueous solutions will be discussed in the second part of this chapter.

It may be useful to summarise the relationships between the actual parameters that are usually measured in the various modifications of the standing wave method. Gaussian units will be used throughout.

### 1. Relationship between dielectric constant and conductivity.

Maxwell's hypothesis states, that if a time variable electric field,  $E e^{j\omega t}$ , is applied to a medium of dielectric constant  $\epsilon$  and conductivity  $\sigma$ , the current  $i$  is given by:

$$i = \sigma E e^{j\omega t} + \frac{\epsilon}{4\pi} \frac{\partial}{\partial t} [E e^{j\omega t}] \quad (1.1)$$

The first part of the expression is in phase with the applied voltage and corresponds to the usual ohmic conduction current. The second term is in phase quadrature with the voltage and is the displacement current. Then,

$$i = \frac{j\omega}{4\pi} \left[ \epsilon - j \frac{4\pi}{\omega} \sigma \right] E e^{j\omega t} \quad (1.2)$$

This can be written as

$$i = \frac{j\omega}{4\pi} \left[ \epsilon' - j\epsilon'' \right] E e^{j\omega t} \quad (1.3)$$

where  $\epsilon'' = \frac{4\pi\sigma}{\omega}$  is often referred to as the imaginary part of the dielectric constant, while  $\epsilon'$  is the real part.

### 11. Relationship between dielectric constant and optical constants.

For a non-magnetic, non-conducting material, Maxwell's

equations yield the relationship

$$\epsilon = n^2$$

where  $\epsilon$  is the dielectric constant. ( $\epsilon = \epsilon'$ , as  $\epsilon''$  vanishes in this case,) and  $n$  is the refractive index defined as  $\frac{\text{Radiation wavelength in vacuo}}{\text{Radiation wavelength in the medium}}$ .

To extend this to a conducting medium, the relationship can still be considered to hold if we make both the refractive index and the dielectric constant complex quantities.

Then writing  $\epsilon = \epsilon' - j\epsilon''$

and  $n = n - jk$

we obtain 
$$\left. \begin{aligned} \epsilon' &= n^2 - k^2 \\ \epsilon'' &= 2nk \end{aligned} \right\} (1.4)$$

$k$  is the absorption coefficient of the medium and it can be shown that the energy loss is proportional to  $\epsilon''$ .

### 111. Relationship between dielectric constant and propagation constants.

Solving Maxwell's equations for electromagnetic propagation in an infinite medium, we obtain the wave equations

$$\nabla^2 H = - \frac{\omega^2 \mu k}{c^2} H$$

and

$$\nabla^2 E = - \frac{\omega^2 \mu k}{c^2} E$$

where

$$k = \epsilon' - j\epsilon'' .$$

If the wave is assumed to be plane polarised and propagated in the  $z$  direction, we can assume a solution of the type

$$E = E_0 e^{+pz} e^{j\omega t}$$

where  $p$  is called the propagation constant of the medium.

Hence,

$$p^2 = \frac{-(\epsilon' - j\epsilon'')\mu\omega^2}{c^2}$$

Assuming  $\mu=1$  for the medium,  $p$  is complex and can be written as the sum of real and imaginary terms:

$$p = \alpha + j\beta$$

$$\therefore p^2 = (\alpha^2 - \beta^2) + j(2\alpha\beta) = \frac{-(\epsilon' - j\epsilon'')\omega^2}{c^2}$$

$$\therefore 2\alpha^2 = -\frac{\omega^2}{c^2} [\epsilon' - \sqrt{\epsilon'^2 + \epsilon''^2}] \quad (1.5)$$

$$\therefore 2\beta^2 = \frac{\omega^2}{c^2} [\epsilon' + \sqrt{\epsilon'^2 + \epsilon''^2}] \quad (1.6)$$

$\alpha$  is the attenuation constant and  $\beta$  the phase constant of the wave. If  $\alpha$  and  $\beta$  are known,  $\epsilon'$  and  $\epsilon''$  can be evaluated.

#### IV. Relationship between dielectric constant and wave guide propagation constant.

Equations (1.5) and (1.6) are valid for propagation in free space, an unbounded dielectric or a coaxial transmission line of infinite length filled with the dielectric. In the case of a hollow wave guide filled with the dielectric, it is necessary to introduce the cut-off wavelength,  $\lambda_c$  and the equations become:

$$p = \frac{2\pi}{\lambda} \sqrt{\left(\frac{\lambda}{\lambda_c}\right)^2 - (\epsilon' - j\epsilon'')$$

$$\therefore \alpha + j\beta = \sqrt{-\left(\frac{2\pi}{\lambda}\right)^2 (\epsilon' - j\epsilon'') + \left(\frac{2\pi}{\lambda_c}\right)^2}$$

where  $\frac{2\pi}{\lambda} = \frac{\omega}{c}$  refers to the free space wavelength of the radiation. Hence,  $\epsilon'$  and  $\epsilon''$  can again be found if  $\alpha$ ,  $\beta$  and  $\lambda_c$  are known.

#### V. Relationship between dielectric constant and reflection and transmission coefficients.

The preceding summary has shown how the dielectric constant can be evaluated in terms of measurable parameters occurring inside the dielectric itself. In many instances, however, it is inconvenient to investigate the field actually within the medium and it may be easier to study the effect that the medium has on an incident wave by measuring the effects of reflection and absorption outside the material. A common experimental procedure in the past has been to terminate the transmission line or wave guide with a reflecting plate situated behind a measured slab of the dielectric. This gives rise to two sets of standing waves, one system outside, the other inside the dielectric. It is a standard result (2) that when a transverse-magnetic wave travelling in an unbounded medium or a coaxial line filled with that medium, of dielectric constant  $\epsilon_1$  (complex), is reflected at the boundary of a second medium of dielectric constant  $\epsilon_2$ , the reflection coefficient is given by:

$$r = r_0 e^{j\phi} = \frac{\sqrt{\epsilon_1} - \sqrt{\epsilon_2}}{\sqrt{\epsilon_1} + \sqrt{\epsilon_2}} \quad (1.7)$$

Similarly the transmission coefficient (also complex)

is given by:

$$t = \frac{2\sqrt{\epsilon_1}}{\sqrt{\epsilon_1} + \sqrt{\epsilon_2}} \quad (1.8)$$

If these waves are travelling inside a dielectric-filled waveguide the relationships are obtained by writing

$\frac{\epsilon_1 - (\lambda/\lambda_c)^2}{1 - (\lambda/\lambda_c)^2}$  instead of  $\epsilon_1$ , in equations (1.7)

and (1.8), where  $\lambda_c$  is the critical wavelength. All these parameters have been used in the past, during investigations to find the dielectric constants of water.

STANDING - WAVE MEASUREMENTS OF  $\epsilon'$  AND  $\epsilon''$ .

Drude (1) first designed an apparatus in which a variable condenser filled with liquid terminated a system of Lecher wires. His wavelength (74cm.) was too long for any anomalous dispersion effect to be detected in water, although it was observable in some of the organic substances he investigated. Drude, however, predicted that water would show anomalous effects, though at lower wavelengths than were obtainable at the time.

Drude's results, like those of many workers using modifications of his technique, are suspect, owing to the fact that their only sources of centrimetric waves were damped. A summary of their work is given by Tear (3) who himself used a free wave method to measure the reflection coefficient of varying thicknesses of water film using a range of wavelengths from 27 to 4 mm. His faulty apparatus led him to claim the discovery of absorption maxima at 20, 7 and possibly 2 mm.

After the development of the magnetron, more reliable work became possible. Bätz (4) measured the reflection and absorption coefficients of water, methyl and ethyl alcohols, at wavelengths from 9 to 2.8 cm. He used a free wave method and his results were in good agreement with those obtained by extrapolating the results at longer wavelengths of Von Ardenne, Groos, and Otterbein (5).

Another worker to use the free wave technique was Knerr (6) who also used a guided wave method at higher wavelengths. His method was similar to optical practice even to the extent of using parabolic mirrors and a grating to focus and reflect his beam. He found that for water, working in the range 6 to 20 cm., the absorption increased monotonically with decrease in wavelength.

An interesting modification of Buz's method is described by Kebbel (7). On finding his results to be dependent on the orientation of his dielectric slab relative to the standing wave pattern, he frequency-modulated his magnetron by superimposing a small, variable magnetic field on the steady one. This modulation was of such a magnitude that the interference pattern due to the slab thickness remained unchanged but was no longer dependent on the position of the slab in the field.

A typical transmission line method is described by Slevogt (8) for wavelengths of 250cm., 60cm. and, in a modified form, at 16 and 10cm., who used it to investigate water and organic solutions. His concentric line system was filled with the liquid under investigation, the liquid depth varied by means of a movable short circuit and the signal measured with two thermocouples, one in the surface, the other a fixed height above the surface. Results were in good



agreement with Debye's theory. Roberts and Von Hippel (9) describe a very similar method, the only essential difference being a fixed short circuiting termination and sliding detectors. From the standing wave ratio  $\frac{E_{max.}}{E_{min.}}$  and the wavelength,  $\epsilon'$  and  $\tan \delta = \frac{\epsilon''}{\epsilon'}$  were evaluated.

Collie, Ritson and Hasted (10) used a rectangular waveguide to measure the absorption of water at 10 cm.. The attenuation was compared with that due to a calibrated piston attenuator. A resonance method was also used at the same frequency and acted as a check. In a later paper (11), the authors used sets of wave guides near cut-off to investigate the dielectric properties of water and heavy water at 10 cm. and 3.2 cm.. At 1.3 cm., a resonance method was found preferable. Good results over a temperature range from 0°C to 75°C were obtained and an accuracy of  $\pm 1\%$  was claimed.

Corroboration for Collie, Ritson and Hasted's results has since been given by Buchanan (12), Little (13), and Saxton and Lane (14). Buchanan used a null method, in which energy passing through a water cell and phase changer was balanced out against a signal which originated from the same source and passed down a cut-off attenuator. By this technique the result was obtained as a function of the settings of the

attenuator and phase changer only, and was independent of any fluctuations in output of the source and any discontinuity in the characteristic of the receiving crystal. A wavelength of 3.2 cm. was used and results obtained over a wide temperature range. Buchanan claimed an accuracy of  $\pm 1\%$  between  $20^{\circ}\text{C}$  and  $40^{\circ}\text{C}$ ., and there is no apparent reason why his apparatus should not be used at 10 cm. with equal accuracy.

The method used by Little was a modification of one first suggested by Flint and Williams (15) for measuring the terminating impedance of Lecher lines. Little developed a twin probe method using a rectangular waveguide, in which the ratio of two signals was observed, the probes being at a fixed relative distance to each other and the surface of the liquid. This method is again independent of any fluctuation in input signal and the actual law of the detectors need not be known, always assuming that both detectors obey the same law. Little's readings were taken with water at 10 cm. and from his values of  $\alpha$  and  $\beta$ ,  $\epsilon'$  could be calculated to  $\pm 0.5\%$  and  $\epsilon''$  to  $\pm 1\%$ .

Saxton and Lane (16) in their initial method used free waves to measure the reflection coefficient and absorption due to a thin film of water. Their results were in good agreement with Collie, Ritson,

and Hasted's except at very high temperatures. In their later experiments (14) they used a method similar to that of Collie, Ritson and Hasted, measuring the attenuation rate in water contained in pairs of cylindrical wave guides near cut-off. The method was to maintain a fixed rectified output by balancing the obtained attenuated signal against that produced by a standard piston attenuator. Thus, again, the crystal response and variation in output could not affect the result. All connections and probes were polystyrene filled wave guides, the  $H_{11}$  mode being used throughout. Readings were taken from  $50^{\circ}\text{C}$  down to the super cooled state and results were found to be continuous down to  $-8^{\circ}\text{C}$ . The results were consistent with previous findings and accurate to 1%. They indicated a single relaxation time for water and showed that the best value for the dielectric constant due to electronic and atomic polarisations,  $\epsilon_0$ , is 4.9 rather than 5.5, the value previously used.

The authors suggest that with further refinements in the apparatus, an accuracy of 0.1% could be reached. This seems to be the ultimate order of accuracy of any absolute method.

RESONANCE METHODS FOR DIELECTRIC CONSTANT MEASUREMENT.1. Theory.

The  $q$  of a resonant system is generally defined as:

$$q = \frac{\text{Energy stored in the system}}{\text{Energy dissipated per cycle of oscillation}} \times 2\pi$$

For a simple circuit consisting of a resistor,  $R$ , a capacitor,  $C$ , and an inductor,  $L$ , resonating at a frequency  $F = \frac{\omega}{2\pi}$ , the rate of power dissipation in the resistor is  $\frac{1}{2}RI_0^2$  where  $I_0$  is the amplitude of the current. The stored energy oscillates in antiphase between the coil,  $L$ , and the capacitor,  $C$ . At the time when it is zero in  $C$ , it has its maximum value,  $\frac{1}{2}I_0^2L$ , in  $L$ , in the form of a magnetic storage field.

Then, by definition,

$$q = \frac{\frac{1}{2}I_0^2L\omega \cdot 2\pi}{2\pi \cdot \frac{1}{2}RI_0^2} = \frac{L\omega}{R}$$

which is the conventional form of the result, and is sometimes used as an alternative definition of  $q$ .

If the space between the condenser plates is filled with a dielectric of dielectric constant

$\epsilon = \epsilon' - j\epsilon''$  and if resonance now takes place at a frequency  $\omega_r$ , the impedance will have changed from

$$Z_0 = R + j\left(L\omega_r - \frac{1}{C\omega_r}\right)$$

to a new value

$$Z_1 = R + j\left(L\omega_r - \frac{1}{\epsilon C\omega_r}\right) \\ = \left[ R + \frac{\epsilon''}{C\omega_r(\epsilon'^2 + \epsilon''^2)} + j\left(L\omega_r - \frac{\epsilon'}{C\omega_r(\epsilon'^2 + \epsilon''^2)}\right) \right]$$

Writing  $C^* = \epsilon' C$  for the new capacity and putting  $\epsilon''/\epsilon' = \tan \delta$

which is the loss factor, then assuming that  $\epsilon'$  is much greater than  $\epsilon''$ , the new value for  $q$  is given by:

$$q_1 = \frac{L\omega_r}{R + \frac{\tan\delta}{C^*\omega_r}}$$

On removal of the dielectric, if it is possible to vary the size of the capacitor until resonance again takes place at the same frequency,  $\omega_r$ , the  $q$  factor is now

$$q_0 = \frac{L\omega_r}{R}$$

$$\therefore \frac{1}{q_1} - \frac{1}{q_0} = \frac{\tan\delta}{C^*\omega_r L}$$

But at resonance,  $L C^*\omega_r^2 = 1$ .

$$\therefore \frac{1}{q_1} - \frac{1}{q_0} = \tan\delta \quad (\epsilon' \gg \epsilon'')$$

This method of finding a change in  $q$  is used for measuring  $\epsilon''/\epsilon'$  at frequencies that are low enough for the components to be treated as lumped impedances.

The  $q$  factor of a resonant circuit can be determined in two ways: the resonance curve may be traced out by varying the frequency and plotting this against the square of the current as read off directly on a square law instrument. Alternatively, the frequency may be kept constant and the resonance curve obtained by incremental changes in capacity.

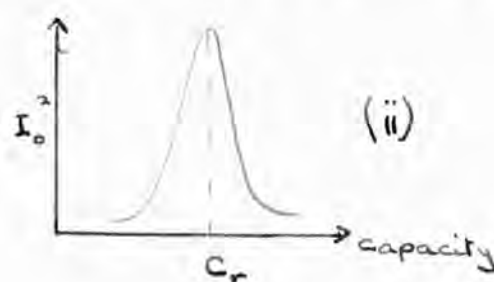
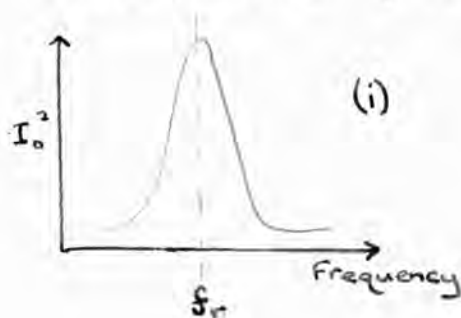

Then, in case (i), the  $q$  is given by  $f_r / \Delta f_r$ , where  $\Delta f_r$  is the width of the resonance curve at half height; in case (ii) it is  $C_r / \Delta C_r$  where  $\Delta C_r$  is again the width of the curve at half height.  $f_r$  and  $C_r$  are the resonant frequency and capacitance respectively.

The resonance method for measuring dielectric constants using an ordinary L-C-R circuit, has been applied by Hartshorn and Ward (17) in their dielectric test set, which can be used between the frequencies of  $10^4$  and  $10^8$  c/s.. At frequencies exceeding  $10^8$  c/s, the circuit of lumped impedances must be replaced by a resonant cavity of either a waveguide or transmission line type, oscillating in one of its characteristic modes. The size and type of cavity is determined by the wavelength at which it is to be stimulated, and by the properties of the medium under investigation. It is generally found that one, or at most two, modes and types of resonator are especially suitable for any particular problem.

The theory of the change in field configuration in both waveguide and transmission line systems on the introduction of a dielectric slab was first calculated by Lamont (18). A table comparing the dimensions and theoretical  $q$  factors of a typical coaxial line, an  $E_{010}$  resonator and an  $H_{01n}$  resonator, all suitable for use at ten centimetres, is given by

Willis Jackson (19). From this it is evident, that the  $qs$  of waveguide cavities are considerably greater than those of the coaxial line type, and of the former, the  $H_{01}$  resonator has the higher  $q$ . For an  $E_{010}$  resonator, the  $q$  curve can only be traced out by varying the frequency, which necessitates a tunable klystron, but when a  $H_{01n}$  resonator is used, either frequency or the resonant length of the cavity may be changed to obtain the curve. Lamont, (20), gives the field distribution and associated theoretical value of  $q$  for several wave configurations.

The resonance method for measuring  $\tan \delta$ , the loss angle, of various, near-perfect dielectrics is described in a paper by Horner, Taylor, Dunsmuir, Lamb and Jackson (21). At wavelengths greater than 50cm., the dimensions of suitable waveguide cavities would be very large, and a coaxial line was used, but at higher frequencies, the higher  $qs$  of the  $E_{010}$  or  $H_{01n}$  cavities made these preferable, and their dimensions were then practicable. Cylindrical cavities were used throughout. When the  $E_{010}$  resonator was used, energy from a variable frequency oscillator was fed to the cavity, and the size of the output signal after squarelaw detection was plotted against the frequency. The change in  $q$  on the introduction of a coaxial specimen, (in the shape of a rod for a

solid and contained in a thinwalled quartz tube for a liquid), was measured. This could be interpreted in terms of the loss-factor and relative permittivity of the rod, if the dimensions of the rod, cavity, and the current penetration of the walls were known. When the  $H_{01}$  mode was used, the actual cavity length was made variable, with the advantage that the klystron output did not have to be calibrated.

Results showed that in practice, for airfilled resonators, the measured value of the  $q$  was no more than two-thirds of the theoretically calculated value, and this had to be corrected for in each instance. Errors were estimated at less than two percent. Low loss solids and liquids only were investigated.

The same method, used for finding the absorptions of dilute solutions of organic polar substances in benzene and the paraffins is described by Jackson and Powles (22). Details of measurements on dielectric slabs at a wavelength of 1cm. are given by Penrose (23), who found an  $H_{01}$  cavity best at the higher frequency.

The use of the resonance method with pure polar liquids is beset with difficulties. Owing to the large absorptions, which greatly reduce the  $q$  and consequently the power available to the detector, it is impracticable to fill the cavity completely

---



with the liquid. A very small quantity of polar liquid in a thin-walled container is usually all that is permissible. The method has, however, been used for measurements on polar liquids by Collie, Ritson and Hasted (24). These workers found that it was not possible to arrange the specimen in such a way as to get a large frequency shift, and still have a resonance curve sharp enough to be measurable. For instance, in an  $E_{010}$  cavity, where the field is maximum along the central axis, in order to obtain a sufficiently sharp  $q$  curve, the coaxial liquid column would have to be less than 0.05mm. in diameter. Collie, Ritson and Hasted therefore chose an  $H_{01}$  resonator in which the coaxial specimen lay in a region of minimum field, and could be accordingly larger. Axial symmetry of the specimen was preferred, since it permitted an exact solution of Maxwell's Field Equations, both with the container alone and with both container and liquid present. For their results with water at a wavelength of 1.25cm., the authors claimed an accuracy of  $\pm 1\%$ , good agreement being obtained when a check was carried out by a standing wave technique.

SUMMARY AND COMPARISON OF THE TWO METHODS OF ABSOLUTE  
MEASUREMENT OF DIELECTRIC CONSTANTS.

An ideal method for measuring the dielectric constant at centimetric wavelengths should conform to the following conditions:

1. Readings should be independent of the observer's position with respect to the apparatus.
2. They should be independent of any fluctuation of the U.H.F. oscillator output.
3. Results should be independent of the detector law.
4. Since both  $\epsilon'$  and  $\epsilon''$  are very temperature dependent, rigid temperature control is desirable, implying a small, compact apparatus, and facility in taking readings quickly.
5. Results should be easily computable.
6. In general not too much of the dielectric should be necessary for one run.

The first condition eliminates all methods using free waves, since high precision independent of the observer can only be attained when the radiation is wholly enclosed in a waveguide or coaxial line.

Conditions 2 and 3 entail a 'null' method such as has been used by Buchanan, Collie, Ritson and Hasted, Little and Saxton and Lane. Resonance methods assume a steady, measured oscillator output, and square law detection.

Conditions 4 and 6, on the other hand, are better

satisfied by resonance methods, since a cavity and mode can usually be found to keep the cavity dimensions small. For the standing wave method, the apparatus is generally a few wavelengths long, while a resonant cavity is half a wavelength long only.

Condition 5 is much better fulfilled by a standing wave method, in which, by the use of fairly simple mathematical analysis,  $\epsilon'$  and  $\epsilon''$  can usually be evaluated exactly. Cavity methods, though generally more sensitive and compact, rely for calculation of results on the solution of Maxwell's Equations for a series of boundary conditions, necessitating the use of Bessel functions and using various approximations. Since the actual current penetration into the walls of the cavity cannot be evaluated exactly, an additional experiment must be performed and an empirical relationship between the theoretical  $q$  and the actual  $q$  formulated. Thus, the limit of accuracy of the resonance method is set at about 1% by the difficulty of calculating results. The possibility of using it for a differential method, in which absolute values are not required, however, appeared to promise an extension to a much higher order of sensitivity.

The limit of accuracy of the standing wave method

in its most refined form is set by the apparatus alone. Thus, Little and Buchanan both circumvent the dependence on crystal law, one by using a ratio of signals, the other a null method. The limit of the former's accuracy is set by the accuracy to which his two signals can be detected and read off on their common scale, the latter's by what he calls "systematic errors" of the apparatus such as the phase change introduced by flexing of the leads, and upset to the balance of the bridge due to generator instability. Each method is particularly suitable for a highly absorbing liquid, such as water, the accuracy decreasing with decreasing loss. There does not seem much hope that the accuracy of the absolute determination of the dielectric constant of aqueous liquids in the ten centimetre region will be substantially improved beyond  $\pm 1\%$  where the standing wave method is used, since the limit is set by a large number of independent quantities, which would all have to be improved simultaneously. The solution would appear to lie in an entirely new technique of measurement.

CHAPTER 11.

---

MEASUREMENTS ON AQUEOUS IONIC SOLUTIONS.

Equation 1.3 has shown that the relationship

$$\epsilon'' = \frac{4\pi}{\omega} \sigma$$

exists between the conductivity,  $\sigma$ , and the imaginary part of the dielectric constant,  $\epsilon''$ .

Much work in the past has been devoted to the measurement of the conductivities of ionic solutions at zero or low frequency. Wien (25), while performing experiments to test the validity of Ohm's law at very high voltages, noticed that his conductivity appeared to be frequency dependent, but his apparatus was not sensitive enough to investigate the dependence quantitatively. In 1928, Debye and Falkenhagen (26) first advanced their theory of the relationship between the conductivities of electrolytes and frequency, and subsequently a number of workers attempted to test its validity, at the highest frequencies that were then available. The Debye-Falkenhagen theory will be discussed in detail in a later chapter.

The methods used for measuring the conductivities were various, ranging from standard resonant circuit techniques such as were employed by Sack and his collaborators (27), (28), Zahn (29), and Deubner (30), to measurement of the heating effect produced in the electrolyte by an alternating current, which was used

by Malsch (31) and Deubner (32) in his second method. A comprehensive description of these methods has been given by Falkenhagen (33). In the majority of cases, the conductivities were measured relative to potassium chloride solution which was taken as a standard.

A notable exception to the usual apparatus employed at that time was that of Drake, Pierce and Dow (34). They measured the dielectric constants of a standing wave system in a concentric line, forshadowing techniques used at a later date when U.H.F. sources became available. The highest frequency used was one corresponding to a wavelength of about 1 metre.

More recently, centimetric techniques, such as described in Chapter 1, have also been applied to aqueous solutions. Collie, Ritson and Hasted (35) used the methods described in their first paper (24) to measure the dielectric constants and loss angles of a number of concentrated ionic solutions at 10cms., 3cms. and 1.25cm. They corrected  $\epsilon''$  for the conductivity contributed by the ionic conduction, subtracting values given for the low-frequency results in the International Critical Tables. From their results they calculated the static dielectric constants and relaxation times of the solutions using Debye's equation which appears to yield satisfactory results. Like Drake, Pierce and Dow, they concluded

that the dielectric constant of the solution (after correction for the ionic conduction) depends only slightly on concentration, being almost the same, though a little below, that of pure water. The results were consistent with the assumption of a single relaxation time. The accuracy in the measurement of  $\epsilon''$  was from two to four percent, consequently any deviations from the value of  $\epsilon''$  of pure water were only detectable at concentrations higher than .5Normal. With this order of accuracy, the experimenters were unable to detect a very small change in dielectric constant such as is predicted by Falkenhagen's theory at these concentrations and frequencies.

Saxton and Lane (36), following their measurements on water, describe work done on saline solutions at a wavelength of 1.58 cm. They made no attempt to separate  $\epsilon'$  and  $\epsilon''$ , but showed that the absorption coefficient at first decreases with concentration, having a minimum at 4%, and then increases again. The explanation offered is that sodium chloride in solution produces a change in the quasi-crystalline structure of water, analagous to that produced by a temperature increase. For small concentrations, (i.e. less than 4%), the equivalent rise in 'structural temperature' is such as to reduce the dipolar conductivity term by an amount exceeding the increase due to its



ionic conductivity.

In view of the lack of experimental results either supporting or disagreeing with Falkenhagen's theory, it appeared to the author that an investigation of dilute ionic solutions at centimetric wavelengths would be very desirable. All previous work appears to have been performed either at low frequencies, or if at high frequencies, then only with concentrated solutions. It was therefore decided to attempt to measure conductivities of dilute solutions of the most common chlorides at a frequency of  $3 \times 10^9$  c/s. At this frequency, which lies within the anomalous dispersion band of water, the Falkenhagen decrease in conductivity for a solution of potassium chloride .001 Normal is predicted to be just under 1%. It was therefore thought desirable to aim for a sensitivity of 0.1% in detecting conductivity changes.

CHAPTER 111

---

THE NEW DIFFERENTIAL METHOD FOR MEASURING CONDUCTIVITIES  
AT CENTIMETRIC WAVELENGTHS.

Introduction.

As the summary of absolute methods given in Chapter 1 indicates, standing wave techniques appear limited, by mechanical difficulties, to accuracies only slightly better than 1%. It was therefore deemed preferable to use a resonant cavity method. As already stated, the absolute evaluation of  $\epsilon'$  and  $\epsilon''$  is controlled by mathematical difficulties in calculating the allowance that must be made for surface effects, but this problem can be overcome by the use of a differential technique, measuring all changes in conductivity with reference to a standard liquid. Distilled water was chosen as the reference liquid.

At first, a method was tried, in which small containers of water and the liquid under consideration were introduced in turn into a cavity resonant at 10cm., each container continuously replacing the other at intervals of half a second. It was hoped that the change in signal picked up by a probe penetrating into the cavity could, after amplification, be used to calculate the relative conductivity of the liquids. It was found, however, that it was not possible to make two containers of exactly equal dimensions, which would ideally give rise to zero signal when filled with

the same liquid. The differential method, on the whole, however, gave promise of having the required sensitivity, once mechanical difficulties could be surmounted. Finally, a method was evolved, in which a thinwalled quartz tube was permanently situated in the tuned cavity, water and the salt solution being passed alternately through it. In this way it was assured that the only change in cavity signal was occasioned by the liquid interchange. It will be shown that the amplitude of signal picked up by the probe can be interpreted directly in terms of conductivity change.

#### PART 1.

##### The Apparatus.

A block diagram of the apparatus is shown in Fig.1. The two liquids to be compared were stored in reservoirs situated on a shelf some feet above the cavity, so that they flowed through the tube under their own pressure when the tap was opened. After leaving the reservoirs, the liquids passed through a temperature equalising system, consisting of several yards of intertwined, thinwalled plastic tubing coiled in a tank of water, equipped with a heater and stirrer. They then entered a two-way tap, specially designed to have no 'dead space' in which mixing might occur, before the liquids

FIG. 1.

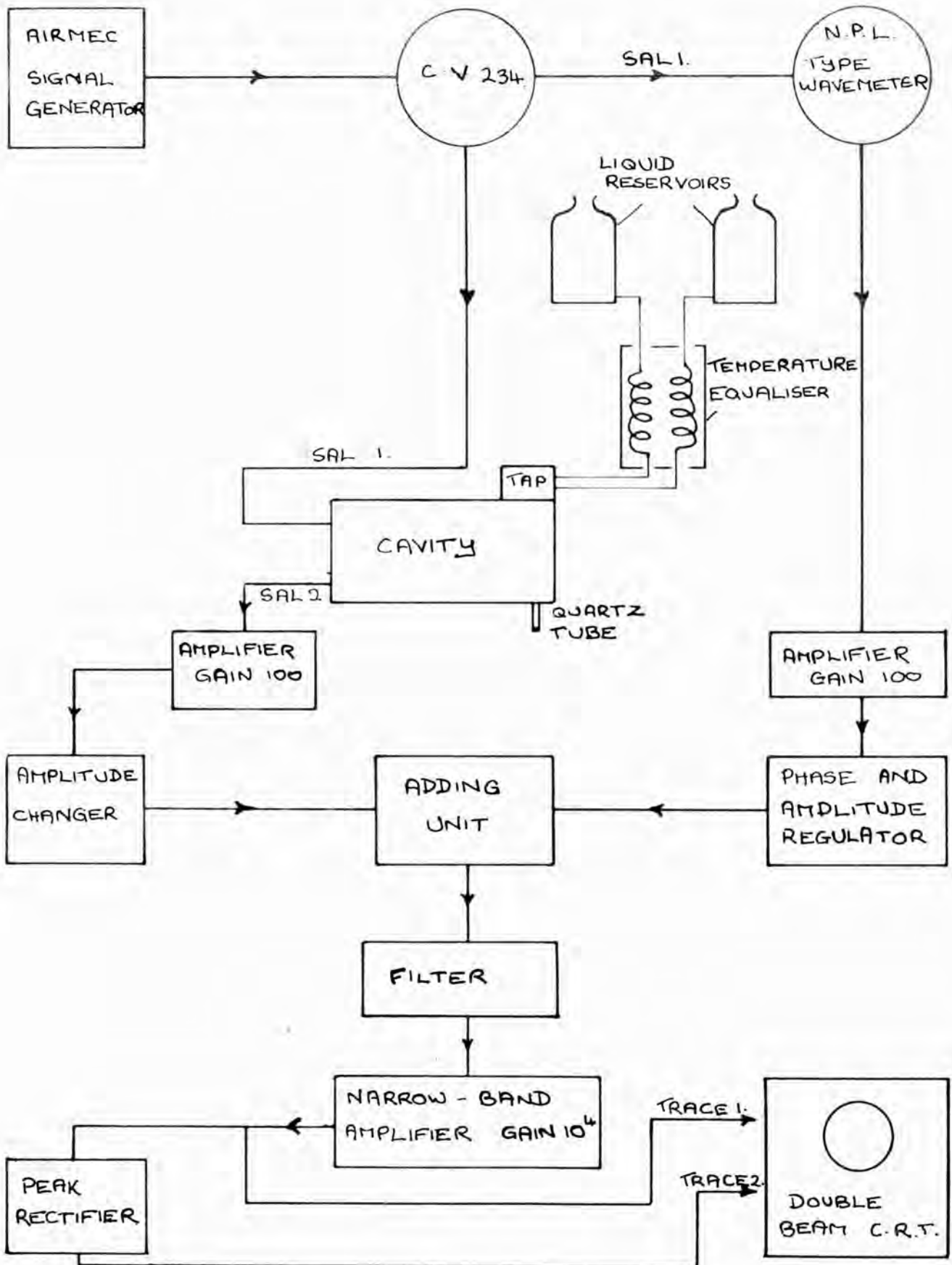

were let into the cavity tube. The tap was driven through reduction gearing by a constant speed motor, slowly enough to ensure that during one cycle each liquid completely replaced the other in the tube. It was found that a driving rate of one cycle in eight seconds fulfilled this condition; during one cycle, water flowed for three seconds, all flow ceased for one second, then the solution flowed for three seconds, followed by another waiting period of one second. A chemical analysis was performed on the last fraction of each outflowing liquid, to confirm that complete substitution had taken place. A copper-constantan thermocouple was placed on the outlet end of the quartz tube, to measure the temperature of the outflowing liquids, while tests were made to ensure that there was no temperature difference between the two liquids flowing into the cavity, by means of another thermocouple connected differentially between the inflow tubes.

The source of ten centimetre radiation was a CV 234 valve oscillator, which was amplitude-modulated at a frequency of 4330 c/s. by the sinusoidal output of an Airmec signal generator, Type 702. The U.H.F. generator valve had two output loops. One was loosely coupled via a

length of SAL.1.type cable of attenuation 10db. to the input probe of the cavity, while the other was similarly coupled to an N.P.L. type cavity wavemeter. To ensure loose coupling with the cavity, the input and detecting loops lay well back in the end face.

The output signal from the cavity was passed through a crystal to rectify the U.H.F. carrier, the resultant signal being at a frequency of 4330 c/s., with an amplitude modulation of one cycle in eight seconds, imposed upon the carrier by the liquid interchange. Any remaining U.H.F. component was attenuated completely by using SAL.2. type cable of attenuation 100db. to feed the signal into an amplifier of gain 100. From this the signal was passed through a unit in which its size could be suddenly reduced by a known small fraction by means of a hand-operated relay switch. It was then electronically added to the wavemeter signal, which had previously undergone similar attenuation, amplification and had also passed through a unit in which its amplitude and phase could be changed at will, independently of each other.

In the adding unit, the amount of 4330 c/s wavemeter signal that was added in antiphase (i.e. subtracted) to the cavity signal, could be regulated by means of a potentiometer. By

this device, the amount of signal eliminated could be controlled until the carrier was 50% modulated even for a very small initial percentage modulation of the cavity signal. The resulting difference signal was passed through an L-C network designed to filter out any harmonics originating in the crystal detector, and thence into a narrow-band amplifier of gain  $10^4$ . From this amplifier, a line passed directly to one trace of a Cossor Model 1049 Double-beam oscilloscope, and this trace was used for tuning and monitoring purposes. A second output was fed into a splitter and peak rectifier, in which the audio-frequency component was rectified, leaving only the slow ripple (1/8 c/s.). This signal was displayed on the other trace of the oscilloscope, after further amplification in the oscilloscope amplifier.

Parts of the apparatus will now be described in greater detail :

#### The Cavity.

A diagram of a cross-section of the cavity and quartz tube is given in Fig.2. Since it was desired to measure conductivity changes only, it was essential that the apparatus should not be sensitive to any small changes in the real part of the dielectric constant; it was therefore decided to use a rectangular cavity, resonating



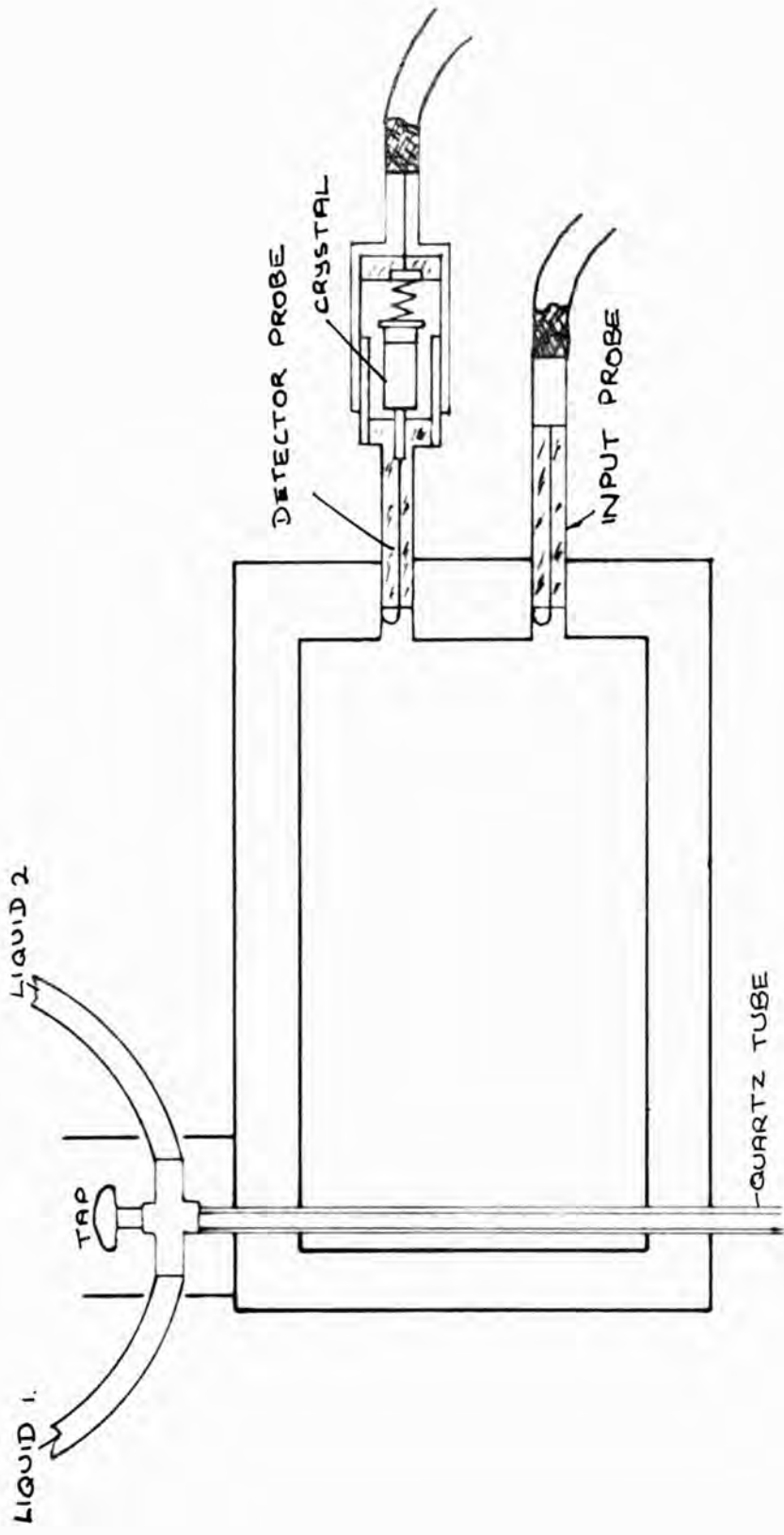

FIG. 2.

in the  $H_{011}$  mode with the quartz tube lying along the centre of one of the short faces, parallel to the lines of electric field. This is a region of minimum field, and an approximate calculation showed that a change in  $\epsilon''$  should make a hundred times more difference to the output signal than a similar change in  $\epsilon'$ .

As shown in Fig.2, the input and detecting loops lay well back within the wall of the opposite short face.

A plan of the cavity and tap is reproduced in Fig.3. The cavity was made up of two pieces of brass channel, each  $1\frac{1}{2}'' \times 1\frac{1}{2}'' \times 4\frac{1}{2}''$  ( $\pm 0.001''$ ), and of wall thickness  $\frac{1}{4}''$ . The inside surfaces were given a polished finish. The pieces were bolted together by means of a brass base-plate, and a polished plate was bolted on to form the end-plate. The front face of the cavity, containing the probes, consisted of an adjustable plunger (a), which could be moved through a traverse of 3" by means of a fine metric thread (b) worked by a milled nut (c). The plunger made good sliding contact with the inner walls of the cavity, carrying with it the input and detector loops (d) and (e). The purpose of the adjustable end plate was to tune the cavity initially at a resonant frequency of exactly  $3 \times 10^9$  c/s. The tuning was then left unaltered throughout all runs. Under

these conditions, the inside dimensions of the cavity were found to be  $3" \times 1\frac{1}{2}" \times 2"$ .

The internal diameter of the quartz tube was .04cm. and the wall thickness was also .04cm.

#### The Tap.

Drawings of the plan and elevation of the tap are shown in Figures 3 and 4.

Water and the liquid under consideration were led through about ten feet of PVC tubing which was coiled in a temperature bath. From this they entered the tap reservoirs (f) by separate brass inlet tubes (g). These were terminated by polythene inserts (h), each perforated by a small hole which was normally blocked by a brass piston (i). Each piston was rigidly fixed to another (j), which could be operated on by the cam (k), unblocking each of the holes in turn. The cam was driven through reduction gearing by an induction motor. After the passing of the cam, the pistons were returned to their resting place by means of steel return springs (l). Each liquid passed alternately, via the small brass T-piece (m) into the quartz tube (n), which was held rigid by a polythene washer (o) fixed in the cavity wall (p).

The tap was designed to have a particularly small dead-space in which mixing of the liquids

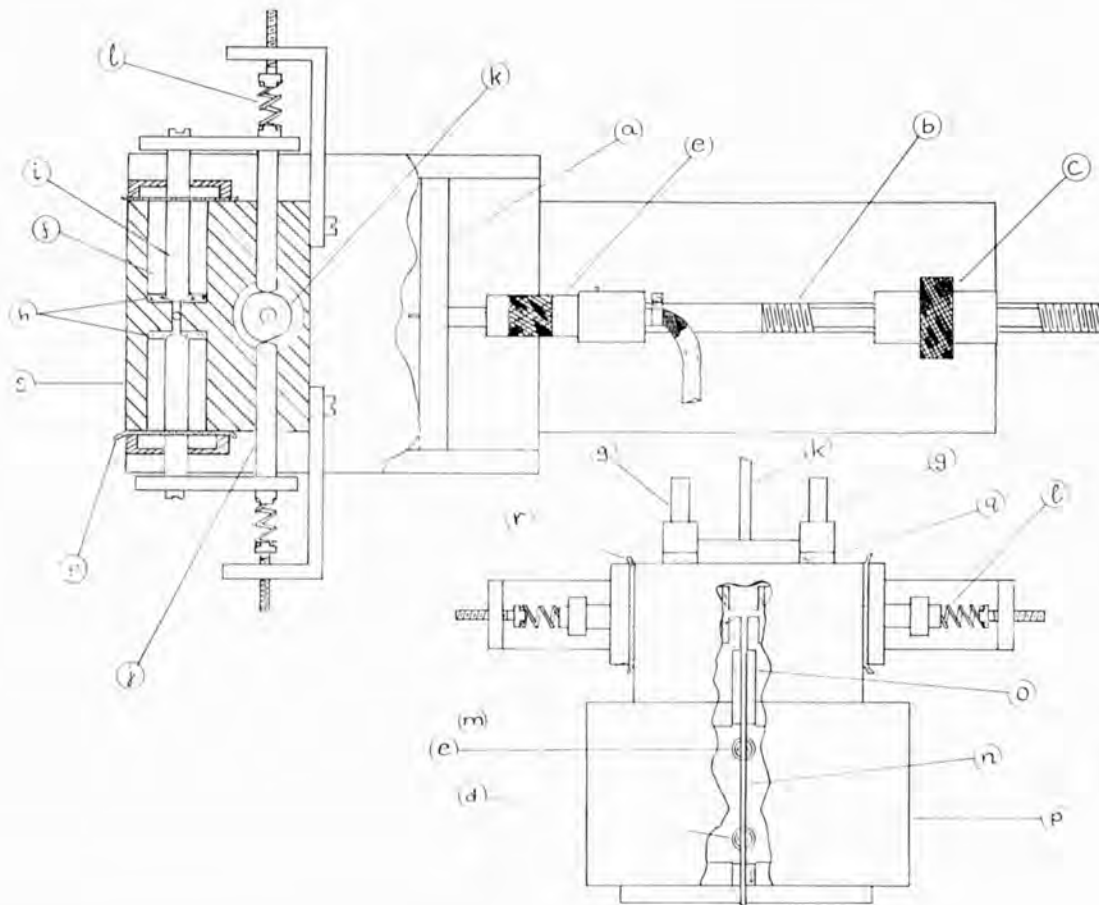

Fig. 3.

Fig. 4.

KEY.

- a - Adjustable plunger.
- b - Fine metric thread.
- c - Nurlled nut.
- d - Input loop.
- e - Detector.
- f - Liquid reservoir.
- g - Inlet tube.
- h - Polythene insets.
- i - Brass piston.
- j - Cam-driven piston.
- k - Cam and cam shaft.
- l - Return spring.
- m - T-piece, (brass).
- n - Quartz tube.
- o - Polythene washer.
- p - Cavity wall.
- q - Polythene washer.
- r - Rubber ring.
- s - Tap wall (brass).

might occur. When the tap was open, about  $\frac{1}{2}$  cc. of liquid passed through at one time, and although the first part of the jet necessarily contained a mixture, the last fraction was pure. This was tested by chemical titration against silver nitrate solution, using potassium chromate, or flurescein as indicator.

#### The Electronic Circuit.

The H.T. line for the U.H.F. oscillator was supplied by a stabilised powerpack of standard design. It was found, however, that an ordinary feed-back stabilised H.T. supply was not sufficiently steady for use with the main amplifier, phasing and adding circuits which are shown in Fig. 5. Since the ultimate sensitivity of the method depends on reducing the inherent noise level to a minimum, the best possible stability of power supplies was required. After some comparative trials, it was decided to take the H.T. supply from a number of ten-volt lead accumulators connected in series, while the heater current was provided by a six-volt battery. All were recharged nightly, and the voltage tested before and during use.

The design of a suitable amplifying circuit, having low noise and high gain, presented a serious problem. Initially, a straight amplifier was tried out, in which six stages of amplification in EF50

pentodes, each stage isolated from the following by a triode cathode follower, yielded a total gain of  $10^7$ . It was found that very careful screening of each component was required to prevent feedback pickup which led to self-oscillation of the circuit. After elimination of high frequency noise components by suitable choice of the time constant of the inter-stage coupling, it was found that the low frequency noise component was still very high. This was noise of the same frequency as the signal and could therefore not be successfully filtered out, but was so large as to mask the smaller signals completely. The trouble was due to 'flicker noise' of the valve, which is a low frequency effect, having a peak value at about  $\frac{1}{2}$  c/s and falling off so as to be negligible at high frequencies. Subsequently, carefully chosen valves of known low flicker noise were used.

The final design of amplifying circuit chosen, successfully eliminated both high and low frequency noise components. This was achieved by using amplitude modulated input signals, having a carrier frequency of 4330 c/s.. After a stage of untuned amplification, the resultant signal was passed into an L-C filter and narrow band amplifier, tuned to 4330 c/s.. This eliminated

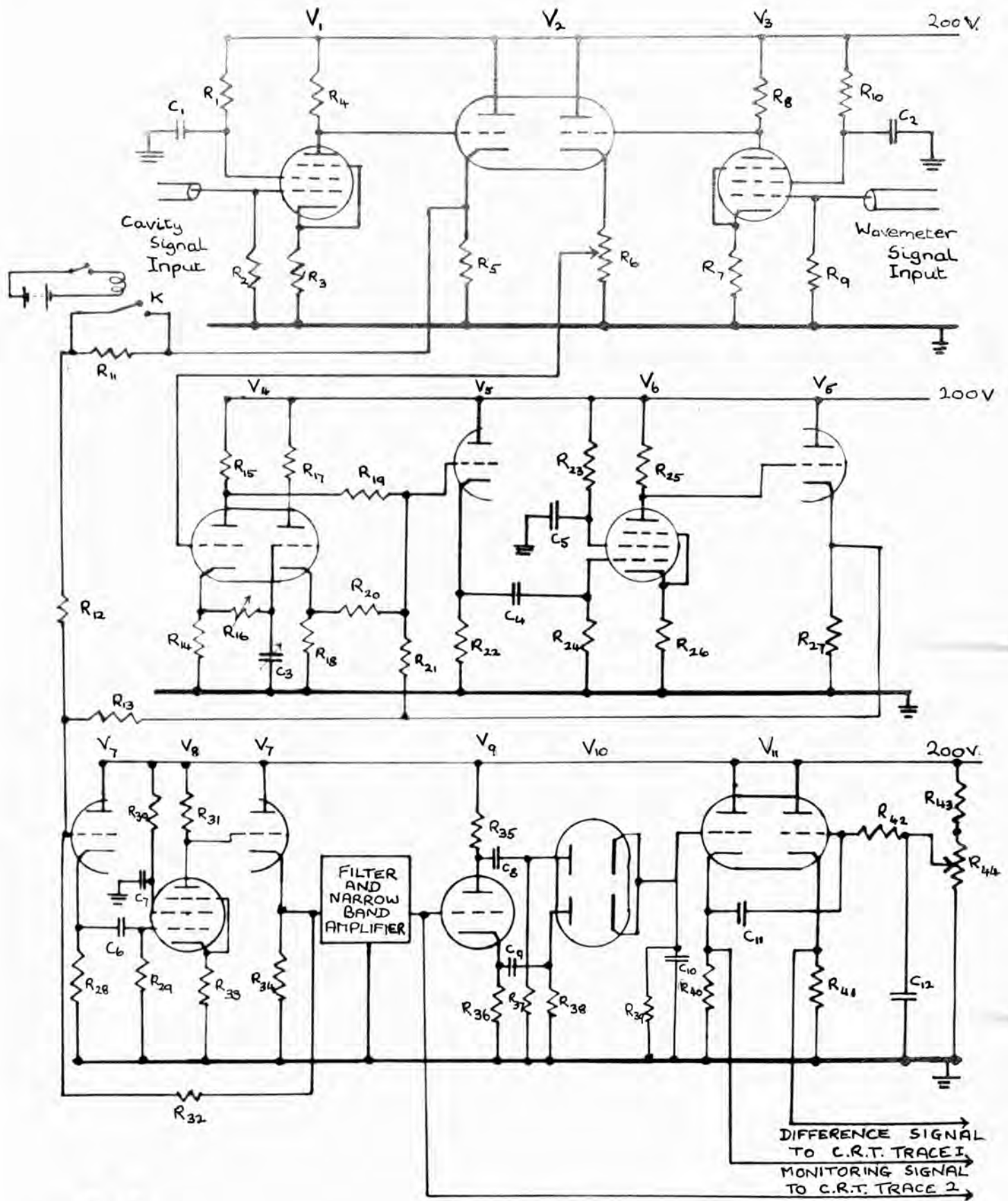

Fig. 5.

all random noise originating in the first stages, allowing only the carrier frequency to pass through. In the final stage, the signal was peak-rectified and the original signal of  $1/8$  c/s. reobtained. A balanced output then ensured that any fluctuations in the H.T. or heater voltage of the last valve were automatically compensated for and did not appear in the final display on the oscilloscope.

Details of the amplifier and adding circuits are shown in Fig.5. The cavity and wavemeter signals were fed directly to the control grids of pentodes  $V_1$  and  $V_3$ , which were type Z279 miniature pentodes. Miniature pentodes and double-triodes were used wherever possible, in order to keep the dimensions of the circuit small and reduce any tendency towards self-oscillation. After amplification by a factor 100, the outputs were taken to two cathode followers, using for compactness, the two components of a double triode B309 ( $V_2$ ). The output of the cavity signal was passed through  $R_{11}$ , which initially consisted of a calibrated 5K ohm Colvern potentiometer, but was later replaced by a fixed resistance of 3,900 ohms, and which was in series with  $R_{12}$ , a fixed resistance of 160K ohms. The resistance  $R_{11}$  could be shorted out by closing the hand operated tapping



key K. It was found by a subsidiary experiment, that the closing of K caused a diminution in the cavity signal of about 1/40 of its original size.

The amplified wavemeter output was taken from the cathode load  $R_6$ , a 40K ohm potentiometer, arranged in such a manner that any required fraction of the signal could be taken, giving complete amplitude control. The phase-changing circuit, consisting of the double triodes  $V_4$  and  $V_5$  (B309s) and the pentode  $V_6$  (2279) was especially designed for this work, and merits a brief description:

The first half of the double triode,  $V_4$ , was used to split the incoming signal into two parts one of twice the amplitude of the other and  $\pi$  out of phase with it. The larger of the signals was passed into an R-C circuit consisting of  $R_{16}$ , a variable  $\frac{1}{2}$  megohm resistor and  $C_3$ , a variable capacitance of .0003  $\mu$ f. In this network the phase and amplitude of the signal were so varied, that in a vector diagram, the locus of the radius vector would have been a semi-circle based on the maximum amplitude. The output from the network was added to the other part of the original signal in the standard adding circuit  $V_5$  and  $V_6$ . This adding circuit consisted of a high gain amplifier

( $V_6$ ) with full feedback, ensuring that the input signals underwent addition with no change in their amplitudes. The cathode follower  $V_5$  supplied the feedback path and also served as low impedance output of the resultant added signal. A mathematical analysis of the phase-changer is given in Appendix 1. This analysis shows, that the resultant signal can be varied in phase at constant amplitude as  $R_{16}$  and  $C_3$  are changed. In this way by changing  $R_6$  or  $R_{16}$  and  $C_3$ , the amplitude and phase of the wavemeter signal could be varied at will, independently of each other.

The cavity signal and wavemeter signal were added together in a similar adding circuit to the one already described, with  $V_8$  the high gain amplifying pentode, and  $V_7$  a double triode supplying a full feedback path. In practice, the phase of the wavemeter signal was adjusted until it was in exact antiphase with the cavity signal, and in this way the output from the second part of  $V_7$  gave only the difference between the two signals. This difference signal was fed into an L-C filter followed by a tuned amplifier of standard design and having a gain of  $10^4$ . In this stage, all low frequency noise was eliminated. From the output of this amplifier, the monitoring signal was taken straight to one trace of the oscilloscope, while the main output was passed into the triode  $V_9$ , connected

as a splitter, since  $R_{35} = R_{36} = 22K$  ohms. The two outputs, equal in amplitude but in antipase with each other, were led into the double diode  $V_{10}$ , type VR54, with the values of  $R_{39}$ ,  $C_{10}$  so chosen that full peak rectification took place, only the  $1/8$  c/s. signal passing on to the double-triode cathode followers  $V_{11}$ . The two components of this valve were connected by the capacitor  $C_{11}$  in such a way that the signal incident on the grid of the first part was fed in antiphase to the second grid, so that a balanced output could be taken between the cathode loads  $R_{40}$  and  $R_{41}$ , thus eliminating from the final signal any fluctuation arising in the valve  $V_{11}$  itself. The final balanced output signal of frequency  $1/8$  c/s. was led into the oscilloscope, where a further amplification of  $10^3$  took place before the signal was displayed on the second trace.

#### Analysis of the Frequency-discrimination and Resultant Signal Output.

The field inside the tuned cavity had a resonant frequency  $\omega$  where  $\omega = 3 \times 10^9$  cycles/sec. It was also amplitude modulated from the klystron at a frequency of  $p$  where  $p$  was of the order of  $4 \times 10^3$  c/s. With water in the cavity, therefore, the signal picked up by the probe of the detector can be represented by the

equation

$$E = C(1 - a \sin pt) \sin \omega t \quad (3.1)$$

where  $C$  and  $a$  are constants of the apparatus. The additional signal that was introduced by the liquid interchange had the effect of a second amplitude modulation, which could be represented by making  $C$  no longer a constant, but variable at a frequency of  $1/8$  c/s.

The probe signal was passed into a crystal rectifier, with a current response that may, in its most general terms, be written as :

$$i = A E + B E^2. \quad (3.2)$$

where  $A$  and  $B$  are constants of the crystal.

Substituting from (3.1), for the crystal current passed on to the amplifier,

$$\begin{aligned} i &= AC \sin \omega t (1 - a \sin pt) + BC^2 \sin^2 \omega t (1 - 2a \sin pt + a^2 \sin^2 pt) \\ \therefore i &= AC \sin \omega t - AC a \sin \omega t \sin pt + \frac{BC^2}{2} (1 - \cos 2\omega t) \left\{ 1 - 2a \sin pt + \frac{a^2}{2} (1 - \cos 2pt) \right\} \\ &= \frac{BC^2}{2} \left( 1 + \frac{a^2}{2} \right) + AC \sin \omega t - \frac{aAC}{2} [ \cos (\omega + p)t - \cos (\omega - p)t ] \\ &\quad + \frac{BC^2 a}{2} [ \sin (p + 2\omega)t + \sin (p - 2\omega)t ] - \frac{BC^2}{2} \left( 1 + \frac{a^2}{2} \right) \cos 2\omega t \\ &\quad - BC^2 a \sin pt - \frac{BC^2 a^2}{4} \cos 2pt \\ &\quad + \frac{BC^2}{8} [ \cos 2(p + \omega)t + \cos 2(p - \omega)t ] \end{aligned} \quad (3.3)$$

In the final expression, the first term, involving only  $C^2$ , had a frequency of  $1/8$  c/s., which period was too long to be transmitted through the first stages of the amplifier. Its contribution was effectively the same as that of a standing D.C. level, and it was not transmitted through the amplifier. Also, since  $\omega$  exceeds  $p$  by a factor of  $10^6$ , the terms involving  $\omega+p$ ,  $\omega-p$  and  $2\omega+p$ ,  $2\omega-p$  were effectively the same as  $\omega$  and  $2\omega$  respectively, and were therefore attenuated in the long lengths of attenuating cable before reaching the amplifier. The only current terms remaining are those involving  $\sin pt$  and  $\cos 2pt$ . In the tuned filter and narrow band amplifier, the frequency response was such that a frequency of  $2pt$  was attenuated 400 times as much as the main frequency  $p$ ; the second term therefore could be neglected in the final output. Hence the only signal to pass through the circuit with no loss was that given by the term  $(BC^2 a \sin pt)$ , which passed to the final peak rectification, the output having the same undulatory frequency as  $C$ , i.e.  $1/8$  c/s. Thus, since the resultant is of the form  $C^2$ , the final oscilloscope reading gave a signal proportional to the square of the signal caused by the liquid interchange.

Part 11.Experimental Procedure.Concentrations of 0 - 0.75 gm./ litre.

Freshly distilled water was used for the reference liquid in one reservoir. With this water in the quartz tube, the end face of the cavity was adjusted until the cavity was resonant at exactly  $3 \times 10^9$  c/s., using the calibrated wavemeter to monitor the output frequency of the CV234. The sliding cavity wall was then kept in this setting throughout all further proceedings.

The solution to be investigated was placed in the other reservoir, and a check was made on the temperature of each liquid entering the cavity to ensure absolute equality. The water in the temperature equalising bath was initially cold, but heated up slowly and steadily throughout a run at such a rate, that the temperatures of the liquids emerging from the quartz tube rose from just below  $18^\circ\text{C}$  to just above  $25^\circ\text{C}$  in an hour. This temperature was read by means of a copper-constantan thermocouple with one junction in ice, the other penetrating a short way up the outlet end of the quartz tube.

At the beginning of a run, the motor driving the tap was set in motion and the heater in the temperature bath was turned on. With the liquids running alternately

through the tube, the rate of temperature rise was sufficiently slow to enable the relative change in signal to be read at intervals of  $\frac{1}{4}^{\circ}$  C. At each temperature, the thermocouple reading was noted, the amplitude of the peak rectified signal ( $S_1$ ) on trace 2 of the oscilloscope was recorded as one liquid replaced the other in the tube, and the hand-manipulated relay switch was closed suddenly. This caused the resistance  $R_{11}$  (Fig.5) to be shorted out, and had the same effect as a reduction of the cavity signal by  $1/42$  of its value. The amplitude of the signal due to this change was also read off on trace 2, ( $S_{11}$ ). The value of the resistance  $R_{11}$  was chosen in such a way that the size of  $S_{11}$  was of the same order as  $S_1$  for very dilute solutions. Although, in theory,  $R_{11}$  could have been changed for every concentration, as long as the effective change of signal due to shorting it were known, it was found in practice that a fixed value of 3,900 Ohms was suitable for all solutions up to and including a concentration 0.75 gm/lit. potassium chloride.

A slightly different method of measurement was also tried and found equally successful: Instead of shorting out a fixed resistance,  $R_{11}$ , and thus comparing the signal caused by the liquid interchange with a fixed fraction of the cavity signal, the

resistance  $R_{11}$  was replaced by a calibrated, 3" Colvern potentiometer of 5K ohms. It was then found possible to find settings of the potentiometer such that, for any given size of interchange signal, the signal due to closing K exactly balanced it out. The reading of the potentiometer dial was recorded at this value. By a subsidiary experiment, it was possible to calculate the equivalent fractional diminution in cavity signal corresponding to any setting of the potentiometer. Therefore, effectively the ratio of the same quantities was measured as in the first method described. It was found, in practice, that it was not necessary to use this 'nulling' technique over the range of liquids and concentrations investigated, since a fixed value for  $R_{11}$  gave sufficient sensitivity. The modification would, however, prove useful with a range of solutions for which the signal varies more than in the present work.

Temperature runs were performed on solutions of potassium, sodium and lithium chlorides, the concentrations increasing in eighths of a gram per litre. For every run, a graph of the ratio  $S_1/S_{11}$  was plotted against temperature. The large number of points, taken at intervals of  $\frac{1}{4}$ °C, enabled small, random noise fluctuations to be ignored, a smoothed



curve being drawn for each solution. The lowest concentrations that gave a measurable signal above background noise were  $1/8$  gm./lit. for potassium chloride and  $1/4$  gm./lit. for sodium and lithium chlorides. At the end of every run, a chemical analysis of the last fraction of each liquid passing through the quartz tube was performed.

Concentrations of  $7/8$  to  $46/8$  gm./litre.

In order to extend the range of concentration to be investigated, a number of runs were performed with solutions of concentrations up to  $46/8$  gm./lit., for potassium chloride only. To keep the signal  $S_1$ , caused by the difference in cavity liquids, of the same order of magnitude as the standard signal  $S_{11}$ , the reference liquid used was not water, but a solution of potassium chloride differing from the concentration under investigation by approximately  $\frac{1}{2}$  gm/lit. For example, a run was performed with a solution of concentration  $4/8$  gm/lit. in one of the reservoirs and a concentration of  $8/8$  gm/lit. in the other. The difference in signal size for water and  $4/8$  gm/lit. was known from previous results, and thus the value of the difference-signal for water and  $8/8$  gm/lit. was obtained by addition. Some justification of this technique was given by a check run performed with concentrations of  $5/8$  gm/lit.

and  $8/8$  gm/lit. in the reservoirs. Comparing results for the difference signals due to water and  $8/8$  gm/lit. obtained in the two different ways, - using  $4/8$  gm/lit. and  $5/8$  gm/lit. as the intermediary solutions respectively, - results were found to coincide exactly. Measurements were made at intervals of concentration of  $1/2$  gm/lit., up to a concentration of  $46/8$  gm/lit.

Concentrations of  $46/8$  gm/litre to Normal Solutions.

In order to calibrate the apparatus and to test the validity of the assumptions made in evaluating the final conductivities, a number of runs were performed using concentrations of up to 1 Normal potassium chloride. A few measurements were also made with higher concentrations of sodium and lithium chlorides.

With these concentrated liquids, using water as the reference liquid, it was no longer necessary to use the relay switch and to compare the liquid interchange signal with a small fraction of the total signal. Since the great difference in concentration caused a correspondingly large interchange signal, it was possible to compare it directly with the actual size of the signal due to pure water in the quartz tube. The procedure was to run the two liquids, alternating continuously as before, and heating the temperature bath up slowly in the manner already described. Only the output signal of

the narrow-band amplifier was displayed on the oscilloscope, this having a frequency of 4330 c/s. without any rectification. As the concentrated solution replaced water in the cavity, the size of the signal was reduced by so great an amount, that the two signal amplitudes could be measured directly and their difference found to the same order of accuracy as the amplified and rectified difference which had been measured for the smaller concentration differences. In this way, the ratio of the difference in signals to the size of the larger signal was found as before. The earlier measurements, using the relay switch with weaker solutions were therefore of the same nature as these later results, the numerical values plotted differing by the factor 42, which was introduced on using the relay switch and the additional amplification in the oscilloscope amplifier.

For a check on the theory developed to interpret the output cavity signals in terms of conductivities, (to be discussed in the next chapter) the  $Q$  of the cavity was determined when air and distilled water respectively filled the quartz tube. This was done in the usual way, by altering the frequency of the C V234 until the output signal from the cavity was reduced to  $1/\sqrt{2}$  of its maximum value on each side of the maximum in turn. The frequencies corresponding

to these reductions were found using the calibrated wavemeter. It was observed that the introduction of water had the effect of reducing the  $q$  of the cavity from a value of 2000 with air in the tube to 1500 with water in the tube. The shift in the maximum tuning frequency caused by the introduction of water was just under 1 megacycle in 3000.

When the highest used concentration of potassium chloride was introduced into the tube in place of pure water, the additional frequency shift was so small that it could not be detected on the wavemeter, i.e. it was less than 1 part in  $10^4$ . This was in keeping with original intention that the liquid interchange should take place in a region of minimum electric field in order that any small differences in the real part of the dielectric constant would not cause a relative frequency shift of the  $q$  peaks. The check has shown that the required condition was adequately fulfilled.

CHAPTER IV

---

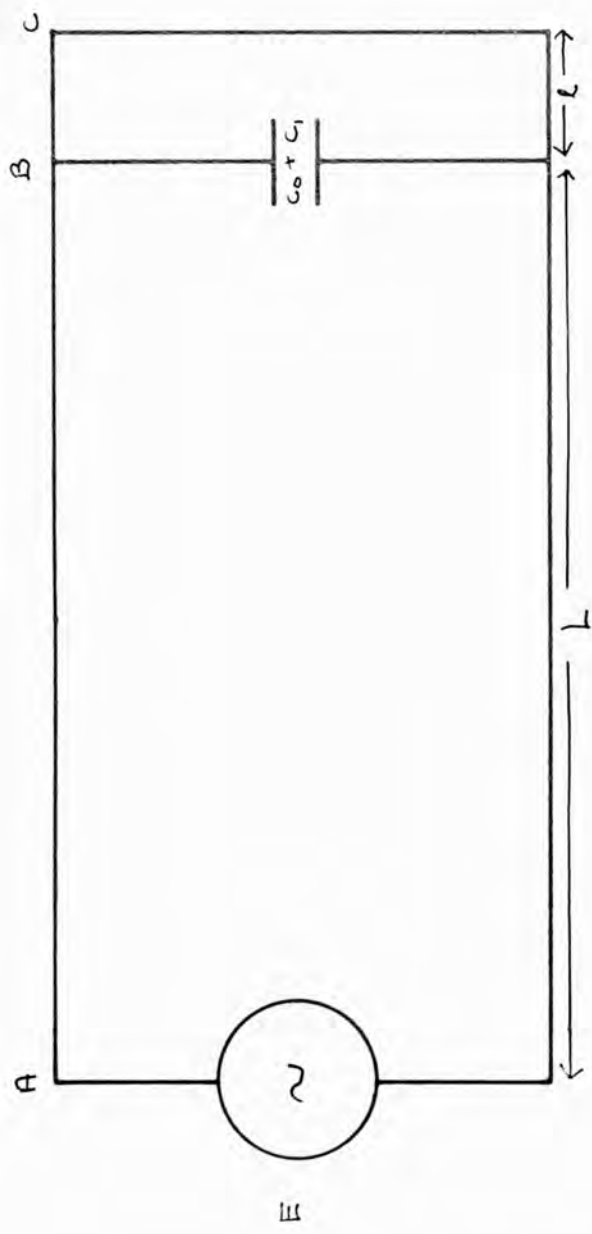

Fig. 6.

Equivalent Line Theory of the Method.

Owing to the central asymmetry of the quartz tube in the cavity, the exact calculation of the  $q$  by evaluating Maxwell's equations presents a practically insoluble problem. An approximate meaning can, however, be assigned to the output signal, by using a transmission line analogue. The technique of replacing a cavity by a transmission line, together with certain lumped impedances, is standard practice, [c.f. Reference (37)].

The standard basic relationships of transmission line theory are assumed. They are derived, for the sake of completeness, in Appendix II at the end of this thesis. A diagram of the equivalent circuit chosen to replace the cavity is shown in Fig.6.

The cavity is replaced by an equivalent line AC, of characteristic impedance  $z_0$ , short-circuited at the ends A and C. The quartz tube is represented by a capacitance  $C_0$  at B, while water is represented by another capacitance  $C_1$  in parallel with  $C_0$ , where

$$C_1 = C(\epsilon' - j\epsilon'').$$

Since the tube was situated so close to the face of the cavity, it is justifiable to assume that the length  $l$  is very small, and the line from B to C may be considered to be loss-free.

Then, if  $z_T$  is the impedance of the terminal

portion of the line, from transmission line theory,

$$\frac{1}{Z_r} = j\omega(C_0 + \epsilon' C - j\epsilon'' C) + \frac{1}{jZ_0 \tan \beta l} \quad (4.1)$$

Where  $\beta$  is the imaginary part of the propagation constant of the line BC, the real part vanishing for a loss-free line.

$$\therefore Z_r = \frac{jZ_0 \tan \beta l}{1 - \omega Z_0 \tan \beta l (C_0 + \epsilon' C) + j\omega \epsilon'' C \tan \beta l} \quad (4.2)$$

Writing

$$\bar{C} = C_0 + \epsilon' C$$

$$\bar{C}'' = \epsilon'' C$$

splitting this into real and imaginary parts, if

$$Z_r = R_r + jX_r,$$

$$R_r = \frac{(Z_0 \tan \beta l)^2 \omega \bar{C}''}{(1 - \bar{C} \omega Z_0 \tan \beta l)^2 + (\bar{C}'' \omega Z_0 \tan \beta l)^2} \quad (4.3)$$

and

$$X_r = \frac{Z_0 \tan \beta l [1 - \bar{C} \omega Z_0 \tan \beta l]}{(1 - \bar{C} \omega Z_0 \tan \beta l)^2 + (\bar{C}'' \omega Z_0 \tan \beta l)^2} \quad (4.4)$$

Similarly, if  $Z_I$  is the input impedance of AC looking from A

$$Z_I = Z_0 \left[ \frac{(R_r + jX_r) \cosh PL + Z_0 \sinh PL}{Z_0 \cosh PL + (R_r + jX_r) \sinh PL} \right] \quad (4.5)$$



Where  $P$  has its conventional meaning of propagation constant of the line  $AB$ .

Then, if  $P = \alpha + j\beta$ ,

$$\left. \begin{aligned} \cosh PL &= \cosh \alpha L \cosh \beta L + j \sinh \alpha L \sinh \beta L \\ \sinh PL &= \sinh \alpha L \cosh \beta L + j \sinh \beta L \cosh \alpha L \end{aligned} \right\} (4.6)$$

For a given frequency,  $\alpha$ ,  $\beta$ ,  $P$  and  $L$  are fixed constants of the line and we can write :

$$\cosh PL = a + jb$$

$$\sinh PL = A + jB$$

$$\therefore Z_1 = Z_0 \left[ \frac{(R_T + jX_T)(a + jb) + Z_0(A + jB)}{Z_0(a + jb) + (R_T + jX_T)(A + jB)} \right] (4.7)$$

$$= Z_0 \frac{(aR_T + AZ_0 - bX_T) + j(aX_T + BZ_0 + bR_T)}{(aZ_0 + AR_T - BX_T) + j(bZ_0 + AX_T + BR_T)} (4.8)$$

At resonance, the imaginary part must vanish,

$$\therefore \frac{Z_{I \text{ Res.}}}{Z_0} = \frac{(aR_T + AZ_0 - bX_T)(aZ_0 + AR_T - BX_T)}{(aZ_0 + AR_T - BX_T)^2 + (bZ_0 + AX_T + BR_T)^2} (4.9)$$

If a voltage source  $E$  is introduced at the input  $A$ ,

the current corresponding to the resonance condition is given by :

$$\begin{aligned}
 i &= \frac{E}{Z_{I, RES}} \\
 &= \frac{E}{Z_0} \frac{(az_0 + AR_T - BX_T)^2 + (bz_0 + AX_T + BR_T)^2}{(aR_T + Az_0 - bX_T)(az_0 + AR_T - BX_T) + (aX_T + bz_0 + bR_T)(bz_0 + AX_T + BR_T)} \\
 &= \frac{E}{Z_0} \frac{(A^2 + B^2)(R_T^2 + X_T^2) + (a^2 + b^2)z_0^2 + 2X_T z_0 (bA - aB) + 2R_T z_0 (aA + bB)}{Aa(R_T^2 + X_T^2 + Z_0^2) + Bb(R_T^2 + X_T^2 + Z_0^2) + R_T z_0 (a^2 + b^2 + B^2)}
 \end{aligned}$$

Substituting for a, b, A, B, from (4.6), leads to

$$\begin{aligned}
 i &= \frac{E}{Z_0} \frac{(R_T^2 + X_T^2)(\sinh^2 \alpha L + \sin^2 \beta L) + Z_0^2 (\cosh^2 \alpha L - \sin^2 \beta L)}{\frac{1}{2} [R_T^2 + X_T^2 + Z_0^2] \sinh 2\alpha L + R_T Z_0 \cosh 2\alpha L} \\
 &\hspace{15em} + Z_0 (R_T \sinh 2\alpha L + X_T \sin 2\beta L)
 \end{aligned} \tag{4.10}$$

When the  $q$  of the cavity was determined with and without water in the quartz tube, the values were found to be 1500 and 2000 respectively. Also, the frequency shift on addition of the water was found to be less than 1 megacycle in 3000. When the water was replaced by as

strong a solution of potassium chloride as 1 Normal, no further change in tuning could be detected.

The large values for the  $q$ -factor imply that both with water and saline present,  $R_T$  was very small compared with  $Z_0$ , (since an increase in  $R_T$  has the effect of reducing the height of the  $q$  peak).

The fact that the change in tuning was so small, was taken to imply that  $X_T$  also was very small compared with  $Z_0$  (since an increase in  $X_T$  effectively displaces the  $Q$ -peak along the frequency scale), and also that  $\beta L$  was very nearly equal to  $\pi$ .

Neglecting terms containing  $\tan \beta L$  in the denominator, equation (4.3) reduces to :

$$R_T \approx (z_0 \tan \beta L)^2 \omega \epsilon'' C \quad (4.11)$$

Also putting  $z_0 \gg R_T, z_0 \gg X_T, \sin \beta L \approx 0$  in (4.10),

$$i = \frac{E}{z_0} \cdot \frac{z_0^2 \cosh^2 \alpha L}{\left(\frac{1}{2} z_0^2 \sinh 2\alpha L + R_T z_0 \cosh \alpha L\right)} \quad (4.12)$$

Combining (4.11) and (4.12),

$$i = \frac{E}{z_0} \cdot \frac{z_0^2 \cosh^2 \alpha L}{\left(\frac{1}{2} z_0^2 \sinh 2\alpha L + (z_0 \tan \beta L)^2 \omega \epsilon'' C z_0 \cosh \alpha L\right)} \quad (4.13)$$

Which is of the form

$$Z = \frac{1}{A + B \epsilon''} \quad (4.14)$$

since  $Z_0$ ,  $\propto L$ ,  $\beta l$ ,  $\omega$  and  $C$  are all constants of the circuit fixed by the dimensions of the cavity and quartz tube.

It has been shown in Equation (1.3), that  $\epsilon''$  can be written

$$\epsilon'' = \frac{4\pi}{\omega} \sigma = \frac{2}{\nu} \sigma$$

in terms of the conductivity  $\sigma$ , where  $\nu$  is the frequency. It is customary to split the conductivity of an ionic solution into two parts:

$$\sigma = \sigma_{Ds} + \sigma_{Is} \quad (4.15)$$

where  $\sigma_{Ds}$  represents the contribution to the total conductivity of the dipolar relaxation, and  $\sigma_{Is}$  is the high frequency ionic conductivity. For pure distilled water, the second contribution vanishes, and the expression becomes :

$$\epsilon''_{\omega} = \frac{2}{\nu} \sigma_{Dw} \quad (4.16)$$

If  $i_w$  is the current in the detector loop when water fills the cavity tube, and  $i_s$  is the corresponding current with salt solution in the tube, then from (4.14),

$$\frac{i_w - i_s}{i_s} = \frac{B(\epsilon_s'' - \epsilon_w'')}{A + B\epsilon_w''} \quad (4.17)$$

In practice, owing to the squarelaw detection (see Equation 3.3) the actual quantity measured is

$$\delta = \frac{(i_w)^2 - (i_s)^2}{(i_w)^2},$$

$$\therefore \frac{i_w - i_s}{i_s} = \left[ \frac{1}{\sqrt{1-\delta}} - 1 \right] = \frac{B(\epsilon_s'' - \epsilon_w'')}{A + B\epsilon_w''} \quad (4.18)$$

Since at any fixed frequency  $\epsilon_w''$  is a constant, combining Equations (4.15), (4.16) and (4.18), the result can be written

$$\left[ \frac{1}{\sqrt{1-\delta}} - 1 \right] = C(\epsilon_s'' - \epsilon_w'') = K(\sigma_{Ds} + \sigma_{Is} - \sigma_{Dw}) \quad (4.19)$$

Where  $k = \frac{2}{\nu} \cdot \frac{B}{A + B\epsilon_w''}$  is a constant.

For a fixed temperature,  $\delta$  was found from the experiments, for every liquid, and  $[(1-\delta)^{-\frac{1}{2}} - 1]$  was calculated.

CHAPTER V.

---

RESULTS.

A graph of  $\delta = \frac{\text{(Difference signal due to salt solution and water)}}{\text{(Size of signal with water in tube)}}$

against temperature was drawn from the results obtained at every concentration. This was found to be a straight line in all cases, with a certain scatter of points depending on the concentration. The limit of dilution was set by the signal that was of the same order as the noise scatter. A smoothed graph was drawn through each set of results, and from this, the values of  $\delta$  were read off at temperatures of 18°C and 25°C. These temperatures were chosen since data are available, in the International Critical Tables, of the low frequency conductivities of dilute solutions of potassium, sodium and lithium chlorides at these temperatures.

Comparison will be made between these D.C. conductivities and those obtained experimentally at the Ultra High Frequency.

Tables I - III give

$$\{[1 - \delta]^{-\frac{1}{2}} - 1\} = C(\epsilon_s'' - \epsilon_w'')$$

at 18°C and 25°C for the lowest measured concentrations of potassium, sodium and lithium chlorides respectively.

Table 1.

Low concentrations of potassium chloride.

Normality	$\{(1-\delta)^{-\frac{1}{2}}-1\}$ at 18°C ( $\pm 0.001$ )	$\{(1-\delta)^{-\frac{1}{2}}-1\}$ at 25°C ( $\pm 0.001$ )
.0021	.0020	.0029
.0043	.0036	.0044
.0064	.0051	.0066
.0086	.0062	.0076
.0107	.0071	.0085
.0128	.0090	.0108
.0150	.0102	.0125
.0171	.0127	.0151
.0171	.0116	.0146
.0214	.0157	.0185
.0300	.0211	.0243
.0385	.0247	.0317
.0470	.0333	.0376

Table 11.

Low concentrations of sodium chloride.

Normality	$\{(1-\delta)^{-\frac{1}{2}}-1\}$ at 18°C ( $\pm 0.001$ )	$\{(1-\delta)^{-\frac{1}{2}}-1\}$ at 25°C ( $\pm 0.001$ )
.0043	.0030	.0042
.0064	.0040	.0052
.0086	.0053	.0066
.0107	.0060	.0074
.0128	.0079	.0099



Table 111.

For low concentrations of lithium chloride.

Normality.	$\{(1-\delta)^{-\frac{1}{2}} - 1\}$ at 18°C (t.001)	$\{(1-\delta)^{-\frac{1}{2}} - 1\}$ at 25°C (t.001)
.0043	.0030	.0037
.0064	.0039	.0051
.0086	.0045	.0061
.0107	.0056	.0063
.0128	.0073	.0089
.0171	.0089	.0109

As has been shown in the previous chapter, at any fixed temperature,

$$\{(1-\delta)^{-\frac{1}{2}} - 1\} = \text{Constant} \times \Delta \xi_s'' \quad (5.1)$$

where  $\Delta \xi_s''$  is used for the difference in  $\xi''$  obtained by the addition of salt ions to pure distilled water. Since no values for  $\Delta \xi_s''$  have previously been obtained at these high frequencies and low concentrations, it is impossible to determine the value of the constant directly, and thus check the theory.

In their later paper, Collie, Ritson and Hasted (35) found that for chloride salts at concentrations of 0.5 Normal and above, there appears to be no difference (greater than 1%,) between the measured U.H.F. conductivities and the ionic conductivities at low

frequencies as listed in International Critical Tables. For this reason the differential method was modified to continue measurements on solutions of much higher concentration, though the sensitivity of readings was necessarily reduced by a factor of about 42, as already described. Runs were performed with concentrations up to 0.5 Normal with all three salts and one measurement was also made with 1 Normal potassium chloride. Using the available D.C. data from tables, and assuming at 0.5 Normal that the High Frequency and Low Frequency conductivities are equal, as shown by Collie, Ritson and Hasted, the conversion constant in the equation

$$\left\{ (1-\delta)^{-\frac{1}{2}} - 1 \right\} = C \times \Delta \epsilon_s \quad (5.1)$$

was evaluated from the results for 0.5 Normal potassium chloride at 18°C. As a check of the assumption, the same constant was calculated from results for 0.5 Normal potassium chloride at 25°C, and also for 1 Normal potassium chloride at the two temperatures. The constants obtained were identical within the limits of experimental error, showing that there is justification for using Collie, Ritson and Hasted's results at high concentration. A mean value for the constant was calculated from the four values, and this was used to evaluate the expected results for 0.5 Normal sodium chloride and lithium

chloride at 18°C and 25°C; agreement with the values of the given D.C. conductivities was found in each case, within the limits of experimental error. This fact was taken as a confirmation of the validity of the equation (5.1) and thus, indirectly, of the assumptions of the equivalent line theory.

The value of the constant of the apparatus given by (5.1) was found to be  $0.46 \pm .01$ .

Values of  $(1 - \delta)$  and  $\{(1 - \delta)^{-\frac{1}{2}} - 1\} = C \Delta \xi''$  for the higher concentrations of potassium, sodium and lithium chlorides are given in Tables, IV, V, VI.

Table IV.

High concentrations of potassium chloride.

Normality	$1 - \delta$		$\{(1 - \delta)^{-\frac{1}{2}} - 1\}$	
	18° C	25° C	18° C	25° C
.047	.939 ( $\pm .03$ )	.927 ( $\pm .03$ )	.032 ( $\pm .03$ )	.039 ( $\pm .03$ )
.094	.894	.877	.057	.068
.147	.849	.827	.085	.100
.188	.832	.815	.096	.108
.210	.796	.772	.121	.138
.248	.798	.763	.121	.144
.250	.760	.715	.147	.182
.295	.765	.730	.143	.171
.376	.717	.686	.181	.207
.500	.660	.625	.231	.265
1.000	.470	.443	.460	.504

Table V.

For high concentrations of sodium chloride.

Normality	$1 - \delta$		$\{(1 - \delta)^{-\frac{1}{2}} - 1\}$	
	18° C	25° C	18° C	25° C
.125	.904 ( $\pm .05$ )	.889 ( $\pm .05$ )	.052 ( $\pm .05$ )	.061 ( $\pm .05$ )
.250	.847	.823	.087	.102
.402	.761	.733	.146	.168
.500	.707	.684	.190	.209

Table VI

For high concentrations of lithium chloride.

Normality	$1 - \delta$		$\{(1 - \delta)^{-\frac{1}{2}} - 1\}$	
	18° C	25° C	18° C	25° C
.0737	.945 ( $\pm .05$ )	.939 ( $\pm .05$ )	.029 ( $\pm .05$ )	.032 ( $\pm .05$ )
.1475	.901	.896	.054	.057
.215	.875	.855	.069	.081
.295	.823	.793	.120	.123
.430	.770	.746	.140	.158
.500	.757	.737	.149	.165
.500	.769	.730	.140	.170

### Errors.

The error figure included in the tables is in each case the maximum deviation, defined as the deviation such that the probability of any point lying outside the limits is less than one part in a thousand.

In order to express the results in terms of conductivities, and not dependent on a constant of the apparatus,  $\{(1-\delta)^2 - 1\}$  was in each case multiplied by the constant  $1/0.46$ , and the values so obtained were conductivity changes,  $\Delta \epsilon''$ , since

$$0.46 \times \Delta \epsilon'' = \{(1-\delta)^2 - 1\} \quad \text{From 5.1}$$

Graphs of the conductivity  $\Delta \epsilon''$  of the salt solution at 18°C and 25°C against Normality were plotted for the three salts.

Graph 1 shows the variation of  $\Delta \epsilon''$  with concentration for the lower and middle concentration ranges, of potassium chloride. It can be seen, that the measured conductivities at these concentrations are everywhere higher than the D.C. values obtained from International Critical Tables; this deviation will be discussed in detail later. The conductivities at the higher temperature were always in excess of those at the lower temperature, a fact that is true at both U.H.F. and low frequencies and is the same for all three salts.

Graphs 11 and 111 show the variation of  $\Delta \epsilon''$  with normality for the low concentrations of sodium and lithium chlorides. It is evident that the same sort of deviation of the U.H.F. conductivities from the D.C. values exists as was observed for potassium chloride, although, owing

# I. KCl.

Specific Conductance, (ohms)<sup>-1</sup>(cm)<sup>-1</sup>

7

5

4

3

2

1

0

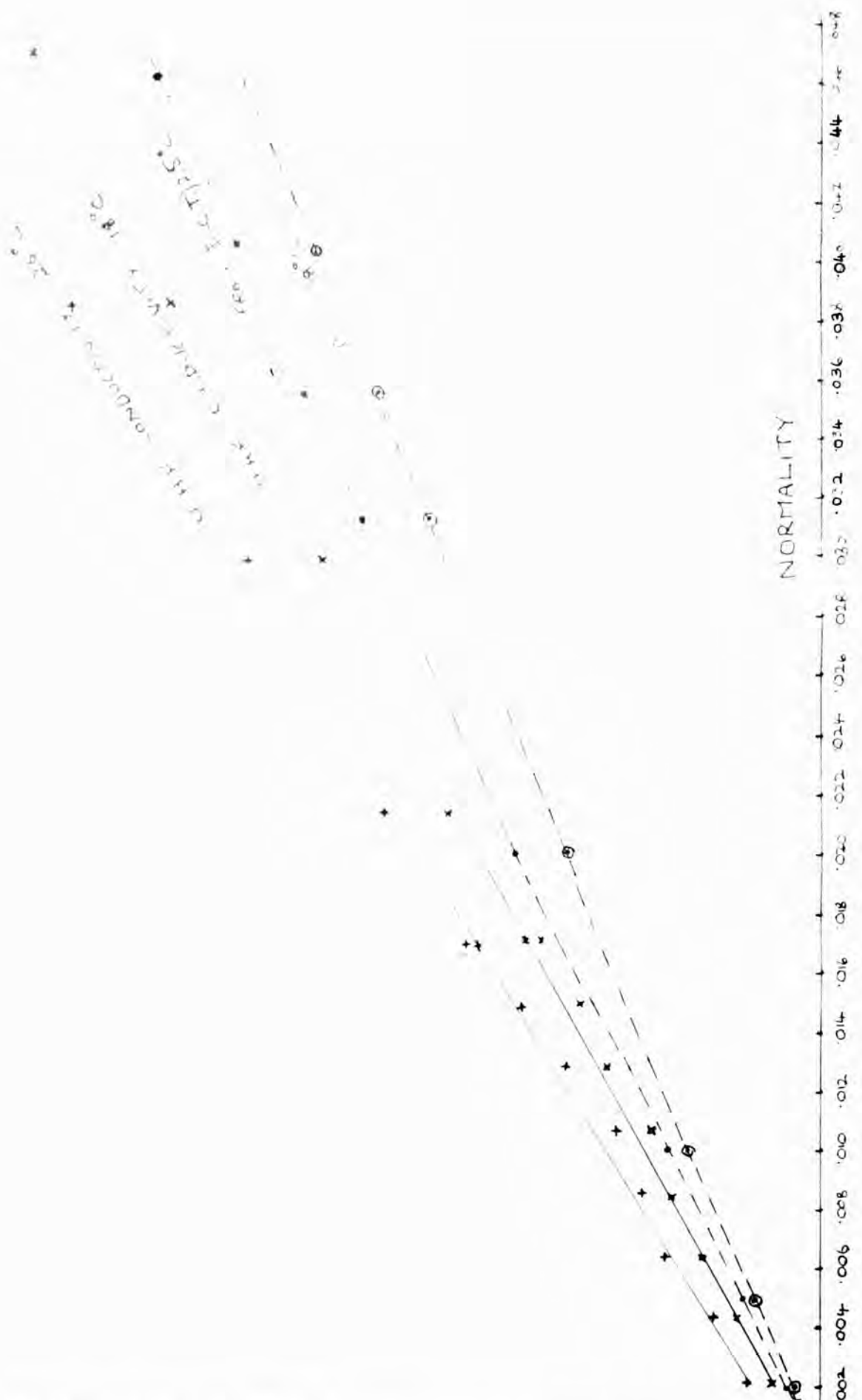

NORMALITY

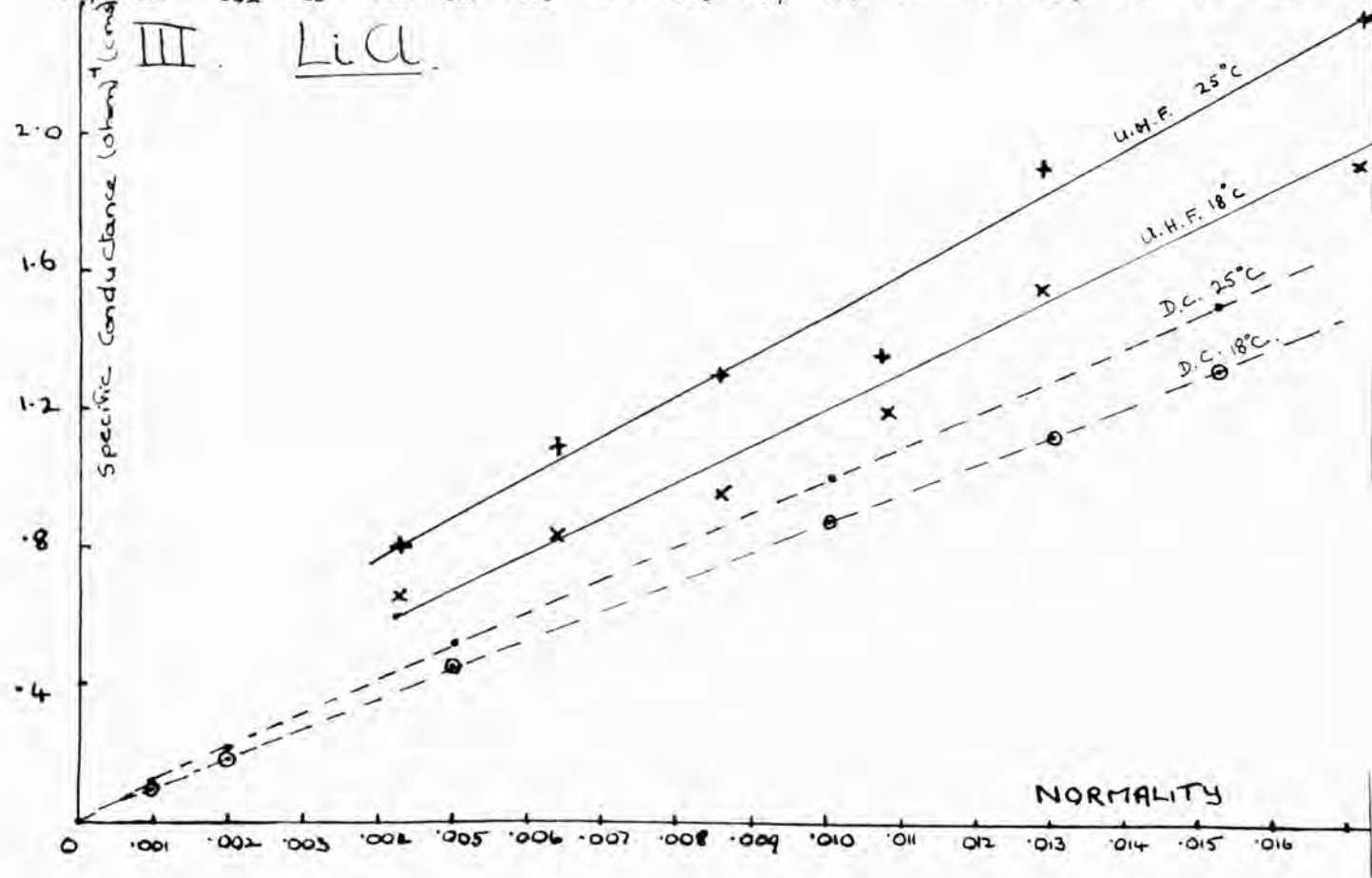
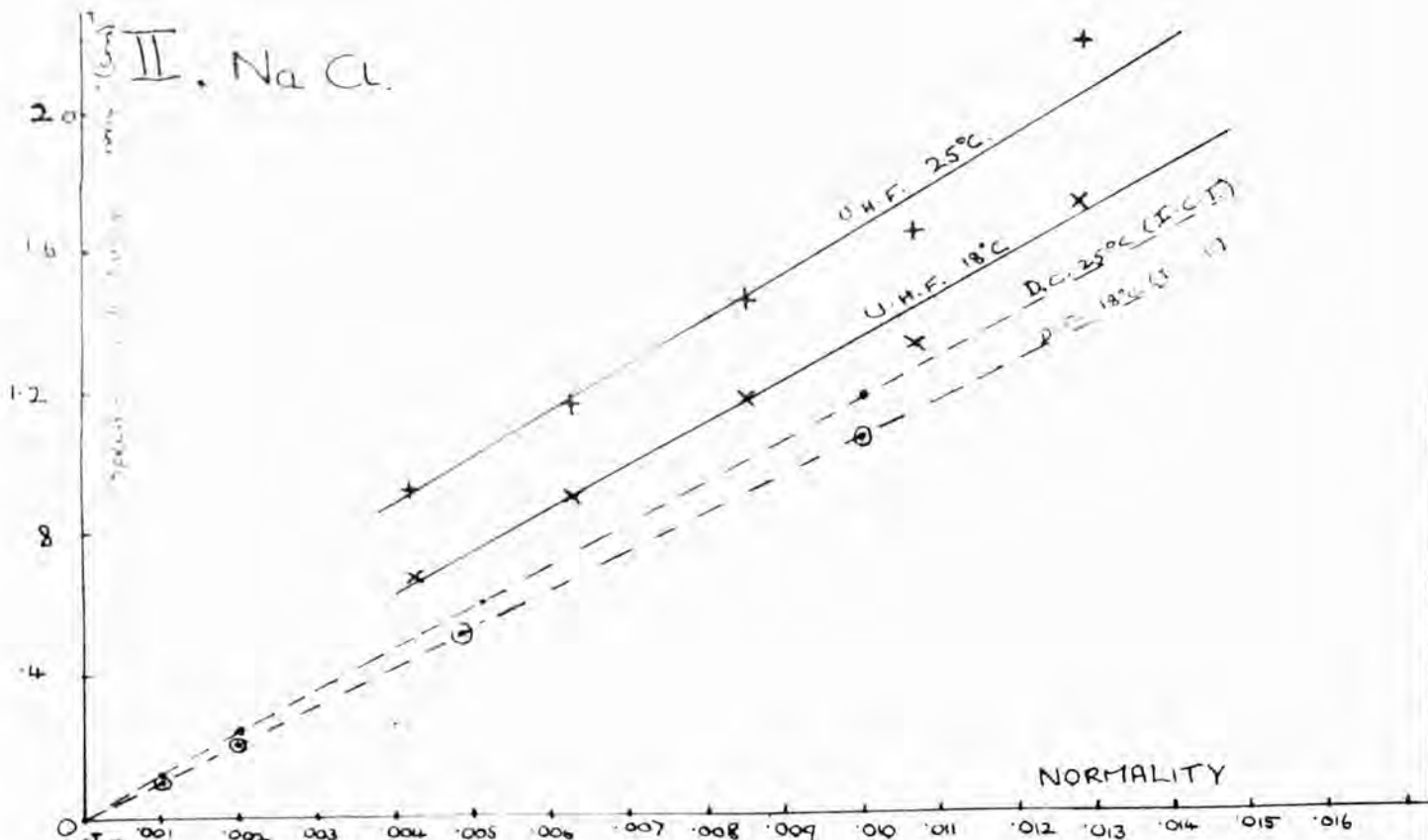

# IV KCl at 18°C

Specific Conductance (ohm<sup>-1</sup> cm<sup>-1</sup>)

18

14

20

16

12

8

4

0

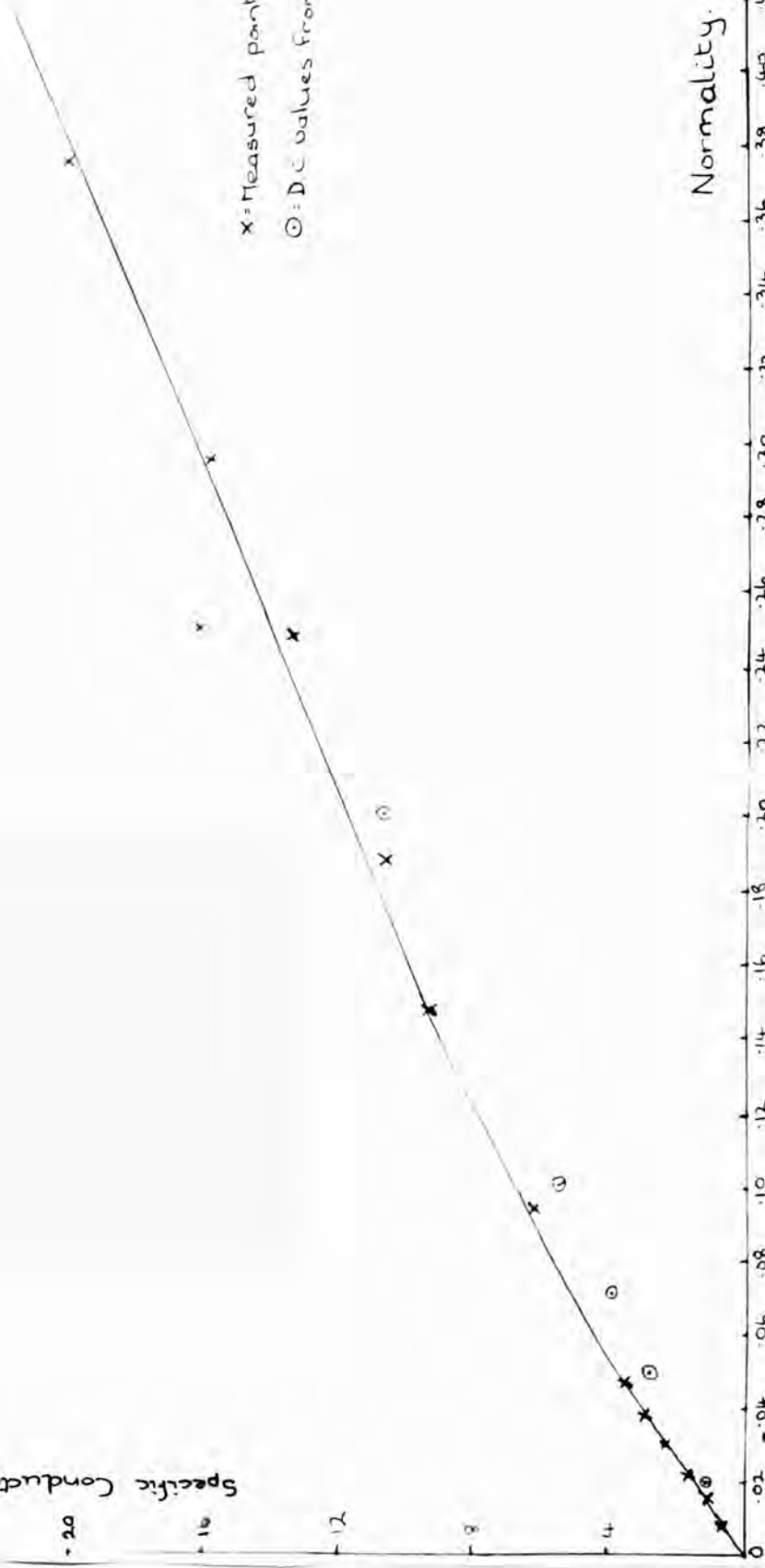

x = Measured points

o = DC values from I.C.T.

Normality

0.02 0.04 0.06 0.08 0.10 0.12 0.14 0.16 0.18 0.20 0.24 0.30 0.36 0.42 0.48 0.50



V KCl at 25°C

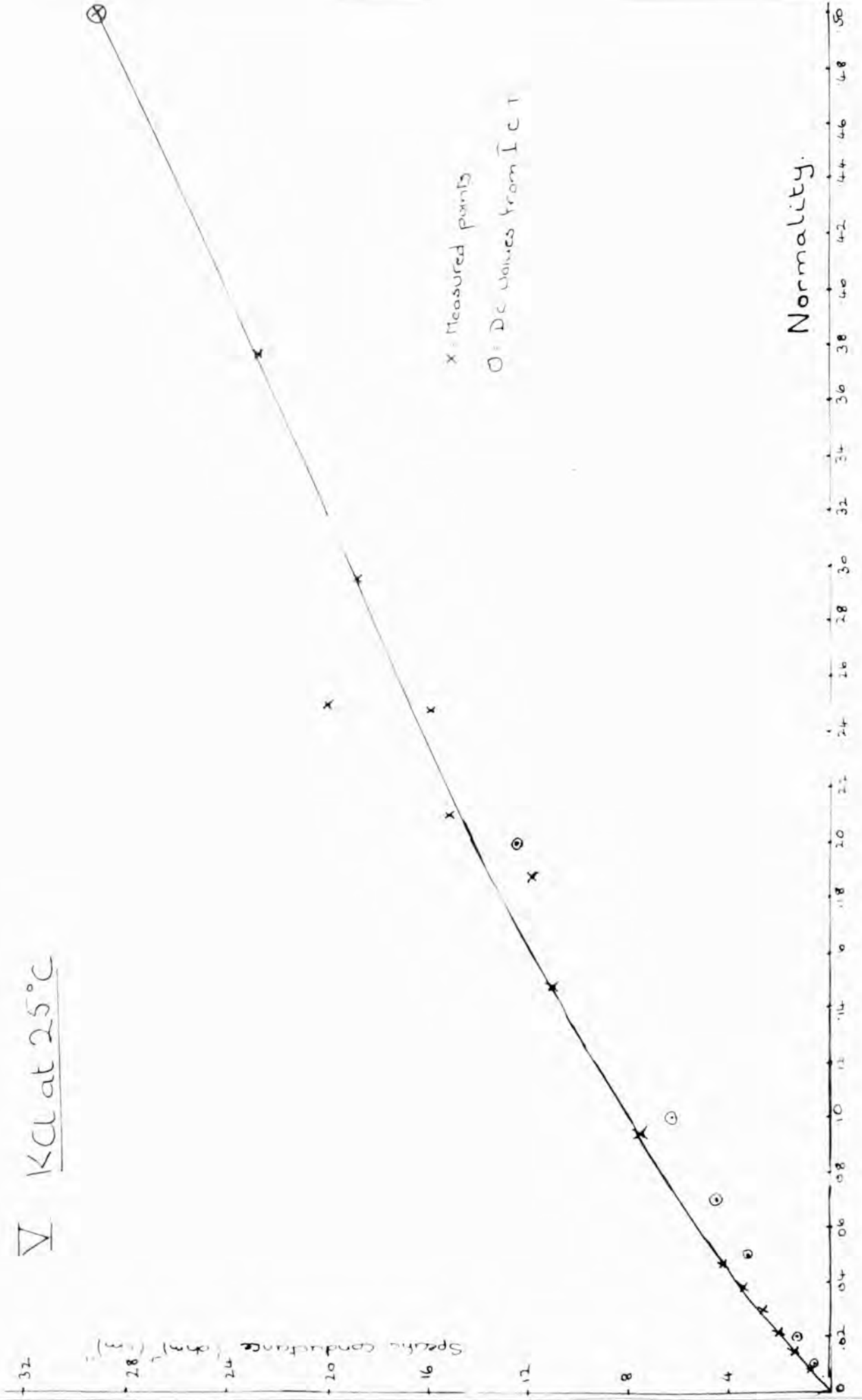

# VI. NaCl

Specific Conductance (ohm) (cm<sup>-1</sup>)

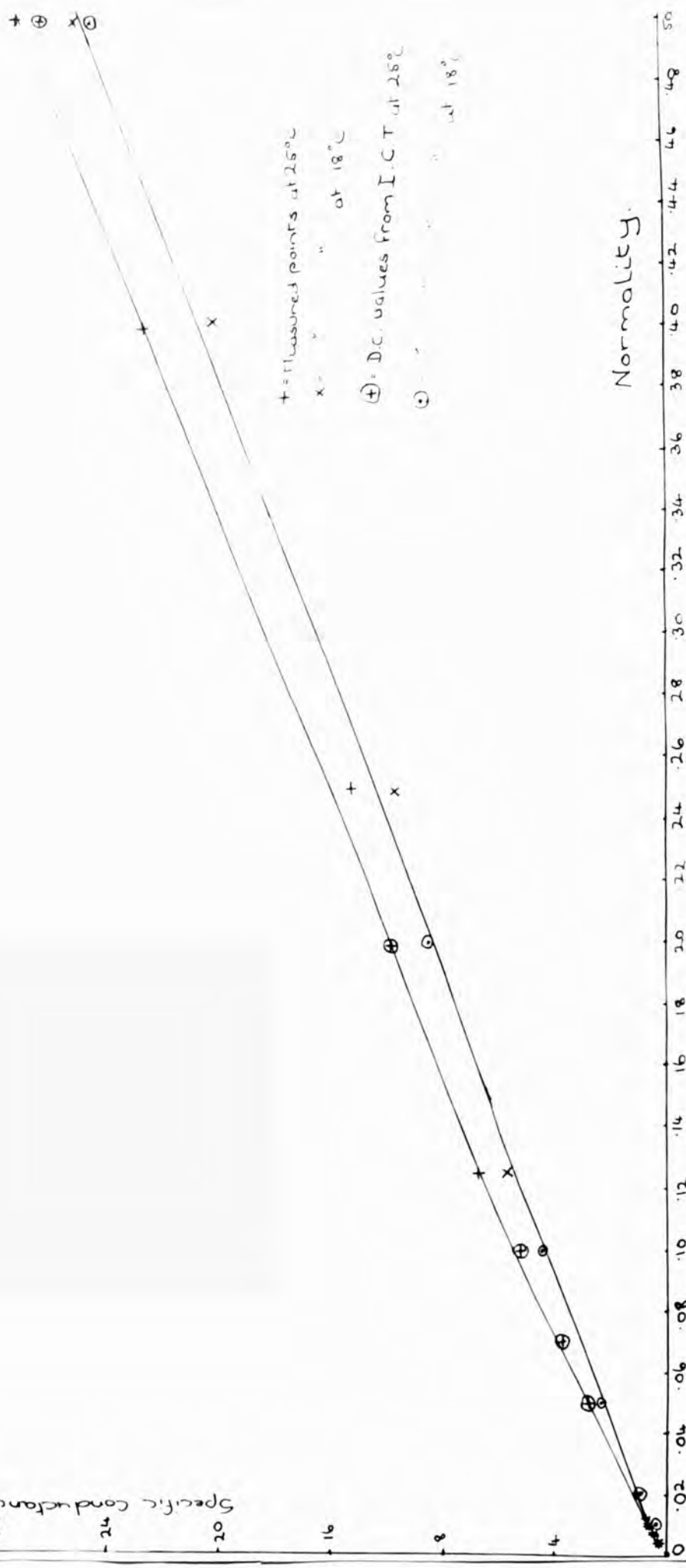

Normality

# VII. LiCl

Specific Conductance (cm<sup>-1</sup>)

⊕ + ⊙ X

⊕ = Measured points at 25°C

⊙ = DC values " " (ICT)

X = Measured points at 18°C

⊕ = DC values " " (ICT)

Normality



to the reduced size of the signal and the fewer measurements made, the results cannot be interpreted with the same accuracy.

Graphs IV and V are for the higher concentration range of potassium chloride at 18°C and 25°C respectively. The D.C. conductivity values are again included and it can be seen that at a concentration of 0.5 Normal, the two values for the conductivities coincide, the coincidence being maintained at 1 Normal.

Similar curves for the higher concentrations of sodium and lithium chlorides are reproduced in Graphs VI and VII.

Since the technique for measurements at these high concentrations necessitates a reduction in sensitivity by a factor of 42, the scatter is consequently wider than for dilute solutions. It is significant, however, that while the D.C. conductivities for potassium chloride sometimes fall within the scatter of the points, they consistently lie below the best mean line drawn through them until the values merge at 0.5 Normal. The fewer points obtained for sodium chloride and lithium chloride, together with the smaller effects observed with these salts, make it impossible to differentiate between the low frequency and high frequency conductivities at the higher concentrations.

### Conclusions.

For potassium chloride at 18° C and 25° C, the low frequency conductivities at low concentrations appear to lie considerably below the measured U.H.F. values. With increasing concentration, the difference grows less and apparently vanishes at a concentration of 0.5 Normal. This is in agreement with results observed by other workers (35).

For sodium and lithium chlorides, a similar trend, though of decreased magnitude for sodium and still smaller for lithium chloride, was found at lower concentrations. Results were not sufficiently sensitive to detect any significant difference between conductivities at U.H.F. and low frequencies in the higher concentration range.

For all liquids and at all concentrations investigated, the conductivities increased with increase in temperature over the range 18° C to 25° C.

### Scope and Limits of the New Differential Method.

If the assumptions made in the section dealing with the equivalent line theory are justified, i.e. if it is true to assume that the whole observed signal is caused by a change in  $\epsilon''$ , the method enables much smaller differences in conductivities to be measured than have been detectable at these frequencies to date. A rough numerical calculation based on the tube and cavity

dimensions shows that with the tube in its given position in a region of minimum field, a change in  $\epsilon''$  would have approximately a hundred times the effect on the output signal as would a similar change in  $\epsilon'$ . Since, according to the findings of Collie, Ritson and Hasted, the variation of  $\epsilon'$  with concentration is very small, and as no change in tuning frequency was detected over the entire concentration range, it seems reasonable to assume that the change in  $\epsilon''$  was the only quantity measured.

The final sensitivity of the method was limited only by the standing noise level in the electronic circuit. The smallest signal measurable above the mean noise level set the limit to the dilution permitted, since when the signal size is of the same magnitude as the random background noise, no further amplification can yield any additional information. As can be seen from Tables I - III, the scatter was of the order of 50% of the interchange signal for a concentration corresponding to .0021 Normal for potassium chloride and .0043 Normal for the other two chlorides. This, therefore, was the limit of sensitivity of the method with the electronic apparatus in its present form.

The second factor affecting the interpretation of the results was temperature sensitivity of  $\epsilon''$ . Owing to the difficulties of keeping the outflowing liquids

at a given temperature for any length of time, it was found preferable to perform a continuous temperature run and read off  $\delta$  at the required temperatures from a smoothed curve. Since each run took over an hour, the total amount of each liquid used was about one litre per run. For liquids which are not as readily available in as large quantities as the ones used in the present work it would be necessary to institute a rigid temperature control, when only a very short run would be required. With suitable modifications in the dimensions of the tube and in the shape and size of the cavity, the method could also be adapted for measurements on non-aqueous solutions and investigations at even higher frequencies.

CHAPTER VI.

---



INTERPRETATION OF RESULTS.The Debye-Hückel Theory of Conductivities.

In very dilute solutions of strong electrolytes, the distribution of ions is not random, since the probability of finding an ion in the vicinity of another of the same sign is less than the probability of finding it near one of opposite sign. A positive ion may therefore be considered to be surrounded by an ionic atmosphere consisting predominantly of negative ions, and conversely, negative ions would be associated with a positive ion atmosphere. A detailed analysis of the distribution of this ionic atmosphere can be found in standard textbooks dealing with the theory of electrolytes, e.g. (33), (38).

Debye and Hückel (39) have shown that due to this ionic atmosphere, the ion is subjected to two retarding influences as it moves in an electric field. The first is the so-called 'disymmetry effect' which is caused by the fact that as an ion moves, the oppositely charged atmosphere tends to lag behind, setting up an electrical retarding force. The second is the electrophoretic effect which arises as a consequence of the solvation of the surrounding atmosphere. Since the ion and the ions of its atmosphere are oppositely charged and tend to move in opposite directions under the influence of an external field, the ion is effectively moving in

a region of solvent being carried in the opposite direction by ions of opposite charge. This introduces an additional retarding force, calculable according to Stoke's Law.

Onsager (40) has modified the early Debye-Hückel theory, introducing a correction for the thermal agitation of the ions in solution. As has already been pointed out, the calculations are only valid for solutions of extreme dilution in which complete ionic dissociation can be assumed. Theories valid for more concentrated solutions, introducing a term for inter-ionic forces, have been put forward by Fuoss (41) and Bjerrum (42).

#### Variation of Conductivity with Frequency:

##### The Theory of Falkenhagen.

If an ion could be instantaneously removed from a solution, the surrounding ions that originally formed its atmosphere would take a certain time before returning to the random distribution that they theoretically occupy in the absence of the ion. This time is known as the relaxation time of the ionic atmosphere,  $\tau$ , and has been calculated by Debye and Hückel from purely dynamical considerations. They obtained the expression :

$$\tau = \frac{\rho}{2K^2kT} \quad (6.1)$$

Where  $f$  is the 'frictional coefficient' of the ions,  $\frac{1}{k}$  has the dimensions of reciprocal length and is called the thickness of the atmosphere and can be calculated for any particular solution,  $k$  is Boltzmann's constant and  $T$  is the absolute temperature. For aqueous solutions of potassium chloride, the value obtained for  $\tau$  from (6.1) is  $\frac{1}{c} \times (0.55 \times 10^{-10})$  sec. where  $c$  is the equivalent concentration of the solution.

In an alternating field of sufficiently high frequency, the ionic atmosphere will begin to lag behind the field, due to its finite relaxation time. This is analagous to the Debye dispersion effect of the dielectric constant in a high frequency alternating field. In the same way as the dipoles lag behind the applied field, the ionic atmosphere is no longer able to follow the movement of the central ion. Thus, if the conductivity of an aqueous solution is measured in an alternating field and the frequency can be increased to a value which is high compared with the relaxation time of the ionic atmosphere, the disymmetry term will decrease and finally vanish. This effect, causing an increase in the conductivity with increasing frequency, was first predicted theoretically by Debye and Falkenhagen (43).

The total molar conductivity of a solution can be represented by :

$$\Lambda = \Lambda_{\infty} - \Lambda_{100} - \Lambda_{11} \quad (6.2)$$

where  $\Lambda_{\infty}$  is the conductivity at infinite dilution and  $\Lambda_{112}$  and  $\Lambda_{11}$  are the modifications contributed by the dissymmetry and electrophoretic effects respectively, at a frequency  $\omega$ . With increasing frequency, the term  $\Lambda_{112}$  diminishes and finally disappears, causing a corresponding increase in the molar conductivity. Since the relaxation time is, in theory, inversely proportional to the concentration, there should be a certain concentration corresponding to each frequency for which the conductivity increase due to the dispersion is a maximum. Sack (27), investigating this practically, found qualitative agreement with theoretical predictions and was also able to say that the observed effects were of the right order of magnitude.

The experiments performed to investigate the validity of the Falkenhagen theory have been described in Chapter 2. All showed qualitative agreement with theory, and, at the limiting range of high dilution over which the theory is valid, fair quantitative agreement was obtained.

If equation (6.2) is applied to a solution at zero frequency, the conductivity is given by :

$$\Lambda = \Lambda_{\infty} - \Lambda_{112} - \Lambda_{11} \quad (6.3)$$

Falkenhagen (33) gives theoretically calculated values

of  $\frac{\lambda_{1.3}}{\lambda_{10}}$  for some typical electrolytes at several concentrations and wavelengths. For potassium chloride at 18°C, at a wavelength of 10 cm. the following data are obtained;

<u>Molar Concentration</u>	$\frac{\lambda_{1.3}}{\lambda_{10}}$	$\lambda_{10}$	$\lambda_{11}$
.0001	.02	.29	.505
.001	.06	.915	1.585
.01	.17	2.91	5.05

If we write the expected increase of molar conductivity due to the Falkenhagen effect in terms of a percentage, then

$$\frac{\text{Increase in conductivity at frequency } \omega}{\text{D.C. conductivity}} = \frac{(\lambda_{10} - \lambda_{1.3}) - 100}{\lambda_{\infty} - \lambda_{10} - \lambda_{11}} \%$$

At a concentration of .0001 Normal, the predicted increase in conductivity would be .2%, at a concentration of .001 Normal it would be .7% and at .01 Normal it is 2.4%. Since the basic assumptions underlying the Debye-Falkenhagen theory depend on the electrolyte being very dilute, no predictions of the increase in conductivities at higher concentrations can be made.

Graph VIII shows the percentage increase in conductivity obtained experimentally in the lower concentration range of potassium chloride at 18°C. The maximum error, as given in Table 1, has been used to

# VIII KCl at 18°C

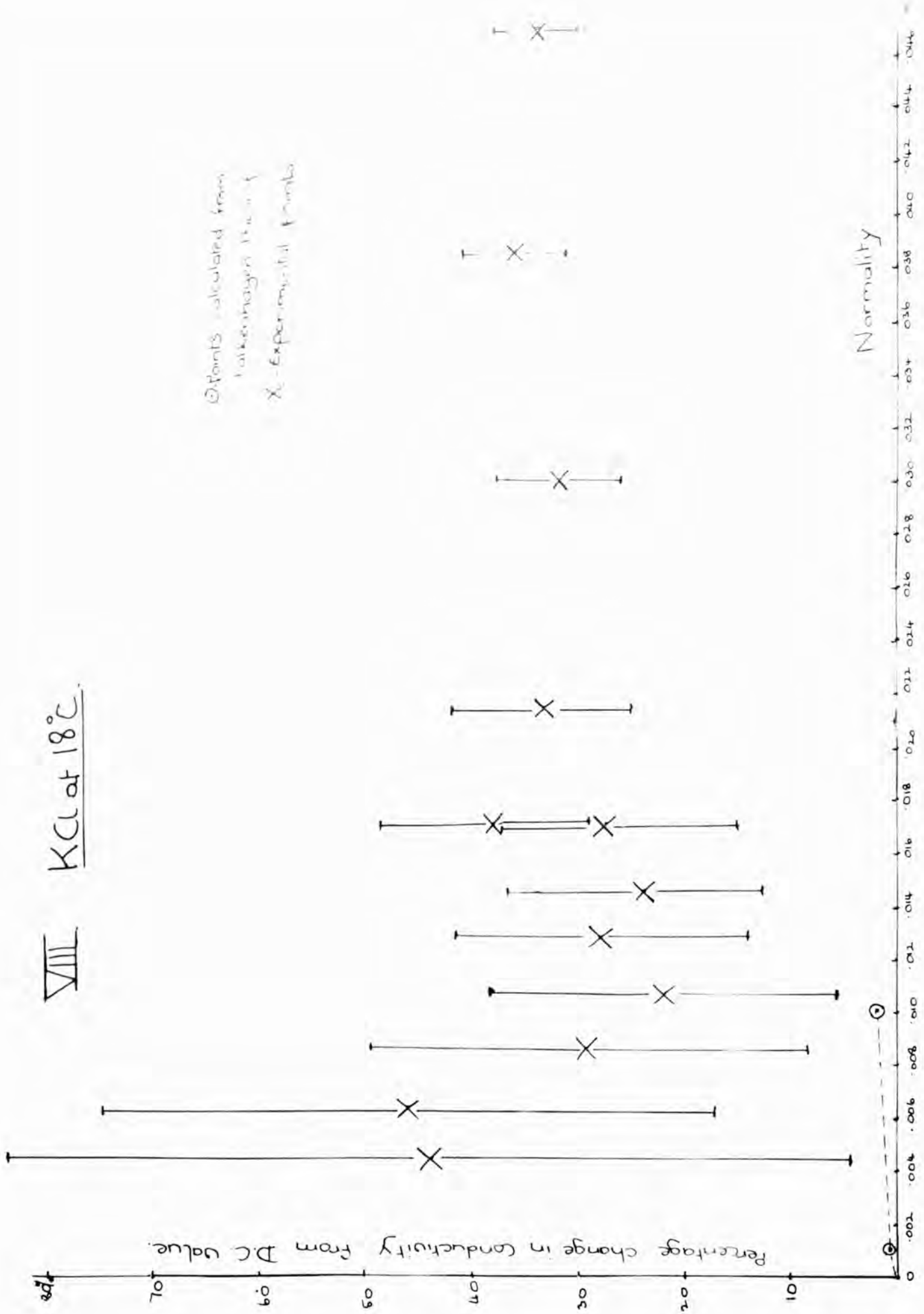

O-points calculated from  
 Kohlrausch's law  
 X - Experimental points

indicate the spread of points. This is considerable at the low concentration end, where the difference between the U.H.F. conductivity and the low frequency value,  $\lambda_{10} - \lambda_{100}$ , is of approximately the same magnitude as the error on the measured quantity itself. The percentage changes in conductivity calculated from Falkenhagen's theory, however, always lie below the minimum value on the graph, even if the error were a maximum.

The consistency of the values obtained for the percentage conductivity change as shown on the graph would seem to indicate that the actual error is not nearly as large as the maximum possible error. Over the concentration range .004 Normal to .047 Normal, the percentage conductivity increase at the frequency of  $3 \times 10^9$  c/s. appears to be constant and about 30% of the D.C. value. This is greatly in excess of the increase predicted by the Debye-Falkenhagen theory.

As has already been mentioned, there is no previous published work on dilute aqueous solutions at these very high frequencies. Some confirmation of the observed results was obtained, however, from work done at Ankara University, using aqueous solutions of magnesium sulphate and calcium sulphate at a frequency of  $24 \times 10^8$  c/s. (43). Quantitatively, the results were not yet ready for

publication, but there appears to exist good qualitative agreement with the effect mentioned here.

A further, though indirect, confirmation which deserves some mention, lies in the results obtained by Gartner (44). Since apparatus for generating waves of sufficiently high frequency to obtain a large conductivity dispersion effect as predicted by the Falkenhagen theory for aqueous solutions was not at that time available, Gartner decided to use glycerine as solvent. Since the relaxation time of glycerine is much lower than that of water, the smallest wavelength then available, about 15m., lies within the anomalous dipolar absorption region described by Debye (46). It was therefore to be expected that the Falkenhagen effect would be observable at the lower frequency for solutions in glycerine.

Using Brendel's apparatus (28), and making measurements on the conductivities of magnesium sulphate and several higher valency salts relative to potassium chloride, Gartner discovered that the relative conductivity rose to as much as six times its D.C. value. Subsequent measurements on pure glycerine showed that the effect could not have been a relaxation effect of the solvent, but that ionic effects were responsible for the increase. No satisfactory explanation of the results was advanced, though a suggestion was put forward that the electrophoretic



term  $\lambda_n$ , could vary with the frequency in some unspecified manner, producing unexpected results. At any rate, the observed increase was far too large to be accounted for solely by the reduction in  $\lambda_{100}$  as predicted by Falkenhagen.

A New Theory to Account for the Observed Variation of  
Conductivity with Frequency.

(This theory has been developed in conjunction with Dr. V.I.Little, Bedford College).

Since it has been shown that the obtained results can not be interpreted in terms of a relaxation effect of the ionic atmosphere alone, a new model has been adopted in an attempt to give a satisfactory explanation. In the new theory the influence of the ions on the surrounding water molecules is considered, an effect not incorporated into the theory of Falkenhagen.

Debye, (46), calculated that within a sphere of approximately 11 Å.U. radius, the water molecules surrounding a monovalent ion are in a region of such great field strength that the dielectric constants are greatly modified. He derived values for a radial and a crossradial dielectric constant, as a function of distance from the central ion, which would have to replace the normal dielectric constants in calculations involving these distances. The concept of dielectric constant, however, implies, by definition, a continuous, homogeneous medium. Very near an ion, the concept loses its validity, and it is necessary to consider individual dipoles, since there can only be small number of these in the space immediately

surrounding the ion. The use of a dielectric 'constant' does not, in this case, seem justified. Bernal and Fowler (47) show, that water molecules approximate to a crystalline quartz-like structure, broken by the thermal motion of the molecules. The introduction of an ion causes a disruptive effect in the structure, in the vicinity of the ion, due to the very intense electrostatic field in this region. Near the ion, therefore, the water dipoles are co-ordinated by the ion, while beyond a critical distance from it, they are orientated by their mutual dipolar attractions. For the present model, the boundary at which the structure breaking effect begins to disappear will be taken to be at a distance of about 8 Å.U. from the ion. This figure has been chosen, since it is that distance from a single positive charge, at which the field due to the charge is equal to the axial field of a water dipole at a distance equal to its longest diameter.

For a complete picture, some assumption must be made about the number and distribution of water molecules in the immediate neighbourhood of the ion. Pople, (48), in his interpretation of the results obtained by Katzoff (49) and by Morgan and Warren (50) in their work on the X-ray spectrum of water, calculated that the best fit is obtained with the

published results by using a model in which the first three shells of neighbours surrounding a water molecule contain four, eleven and twenty-two molecules respectively. A perfectly tetrahedral structure, such as postulated by Bernal and Fowler, would contain four, twelve and thirty-six molecules in the innermost shells. For the sake of the present theory, a model will be adopted in which shells one and two around an ion are assumed to contain four and twelve molecules respectively, though the dipoles will tend to pack as closely as possible around the ion. The third shell, at a distance of 6 Å.U. from the centre, will tend to acquire more molecules due to the presence of the ion, and will be assumed to contain between twenty-two and thirty-six molecules.

The molecules of the three innermost shells are orientated by the field of the ion, i.e., in the absence of an external field, the watermolecules will be aligned radially along the lines of force. Outside these shells, it is assumed that the field due to the ion is small compared with the inter-dipolar forces, and the molecules form their normal water structure. This is, of necessity, a very simple model. There must exist some area of partial orientation, but, for convenience of calculation, the approximation is made that within the three inner shells, the molecules

are totally aligned, while outside this region, they are completely unaffected by the ionic field.

As has been already stated, the concept of dielectric constant cannot be used when calculating the electrostatic field at a point within the inner three shells. In order to find the field due to the central ion at a point on the third shell, therefore, it will be assumed that the field due to the ion has its full effect through the gaps in the screen formed by shells one and two, and that the molecules constituting shell three move round to positions of maximum field, other molecules from outside the shell being drawn inwards to fill any gaps. This accounts for the increase in the number of molecules while the radius of the shell remains unchanged.

The new model thus introduces two basic assumptions:

- 1) that the molecules around the ion are radially orientated and rigidly held by the forces due to the field of the ion;
- 2) that in a spherical shell immediately surrounding the ion, the dielectric constant is effectively that of free space, since due to the large field fluctuations in that region it is not permissible to use an overall average value to represent the contributions due to the innermost water molecules.

If an external field  $E$  is applied, it will be enhanced, due to the polarisation of the medium, and, in all regions excluding the spherical shells in the immediate neighbourhood

Fig. 7

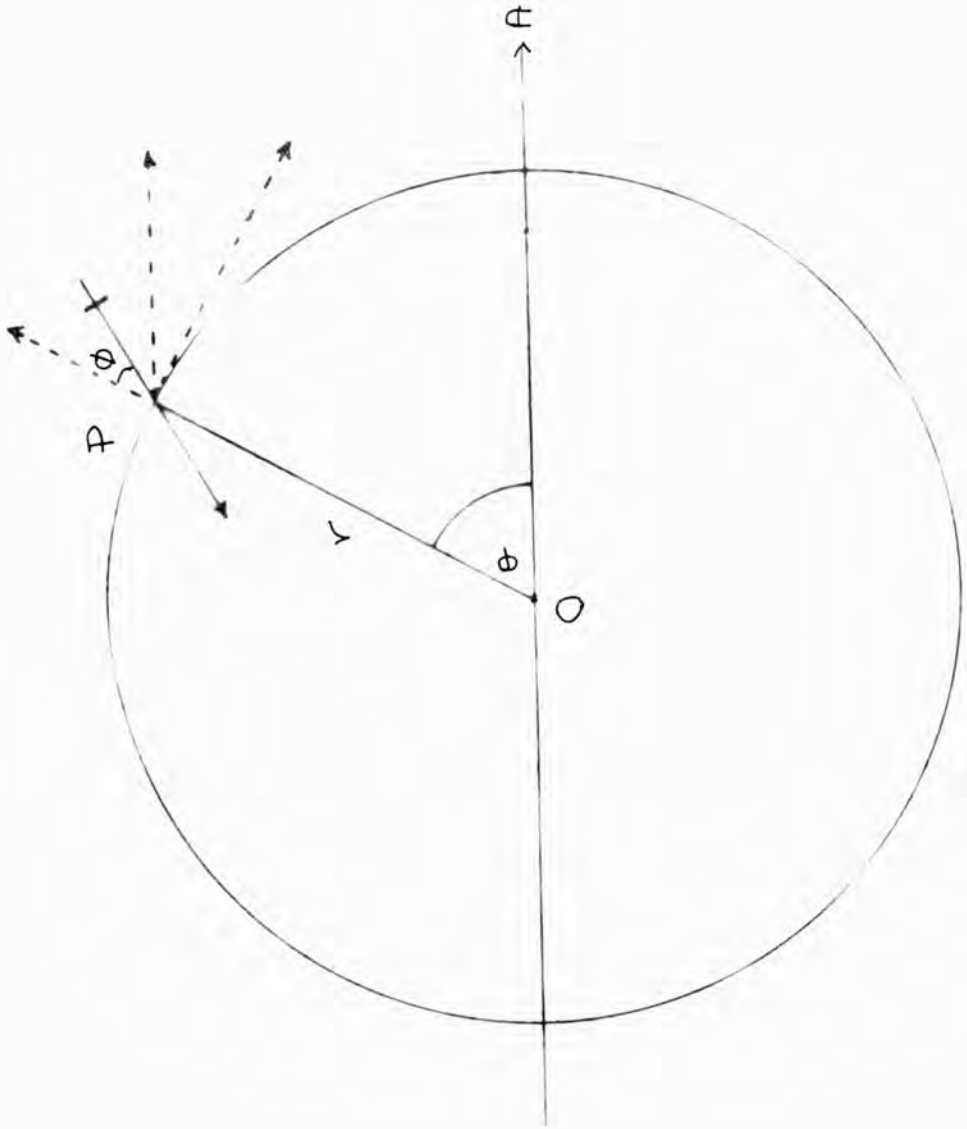

of the ion, it will have a value

$$F = E + \frac{4}{3}\pi P \quad (6.4)$$

where  $P$  is the polarisation, or mean electric moment per unit volume of the solution. Equation (6.4) holds generally for all isotropic dielectrics, the detailed derivation being given in standard textbooks, (e.g. Ref 46). The effect on the polarisation  $P$ , due to the presence of the ions will now be calculated.

Figure 7 shows the effect of an ion on a water molecule of the third shell. Normally, in the absence of an external field, the dipole at  $P$  ( $r, \theta$ ) will be aligned radially due to the field of the ion at  $O$ . If an external field,  $E$ , is applied in the direction  $OA$ , a resultant force  $F$  acts at  $P$  and the dipole will rotate through the angle  $\phi$  where

$$\tan \phi = \frac{F \sin \theta}{e/r^2 + F \cos \theta}$$

( $O$  is assumed to be a monovalent positive ion of charge  $e$ ). Since at a distance of  $6 \text{ \AA.U.}$  (corresponding to the approximate distance of the third shell from the ion,) the field due to the ion is still very strong, in general

$$F \cos \theta \ll e/r^2$$

$$\therefore \tan \phi = k \sin \theta$$

where  $k = \frac{Fr^2}{e}$ .

$$\begin{aligned} \text{Hence } \cos \phi &= (1 + k^2 \sin^2 \theta)^{-\frac{1}{2}} \\ \sin \phi &= k \sin \theta (1 + k^2 \sin^2 \theta)^{-\frac{1}{2}} \end{aligned} \quad \left. \vphantom{\begin{aligned} \cos \phi \\ \sin \phi \end{aligned}} \right\} (6.5)$$

If  $\mu$  is the effective average dipole moment of a water molecule, the contribution to the field at O in the direction OA by the dipole at P is given by :

$$\delta f = \frac{\mu}{r^3} (2 \cos \phi \cos \theta - \sin \phi \sin \theta) \quad (6.6)$$

From the standard equations for the radial and crossradial components of a dipole's field.

Substituting from equation (6.5),

$$\delta f = \frac{\mu}{r^3} \frac{(2 \cos \theta - k \sin^2 \theta)}{\sqrt{1 + k^2 \sin^2 \theta}} \quad (6.7)$$

The total contribution along OA due to all dipoles in the third shell, is obtained by summing  $\delta f$  over all values of  $\theta$  so as to include all molecules in the shell.

$$\therefore f = \sum_{\theta=0}^{\pi} \frac{\mu}{r^3} \frac{(2 \cos \theta - k \sin^2 \theta) n_{\theta}}{\sqrt{1 + k^2 \sin^2 \theta}} \quad (6.8)$$



If a symmetrical distribution of a sufficient number of dipoles can be assumed, the summation may be treated as an integration. Thus, if  $n$  is the total number of dipoles in the shell, the number of dipoles per unit area will be  $\frac{n}{4\pi r^2}$ . Then, for an annular strip of angular thickness  $d\theta$ , situated at an angle  $\theta$  with OA, contribution of field at O along OA will be :

$$df_{\theta} = 2\pi \sin\theta r^2 d\theta \cdot \frac{n}{4\pi r^2} \cdot \frac{\mu}{r^2} \frac{(2\cos\theta - k\sin^2\theta)}{\sqrt{1+k^2\sin^2\theta}} \quad (6.9)$$

For the total field along OA due to the entire shell, it is necessary to sum over all angles.

$$\begin{aligned} \therefore f &= \int_0^{\frac{\pi}{2}} \frac{n\mu \sin\theta (2\cos\theta - k\sin^2\theta) d\theta}{r^2 \sqrt{1+k^2\sin^2\theta}} \\ &= \frac{n\mu}{r^2} \int_0^{\frac{\pi}{2}} (2\sin\theta \cos\theta - k\sin^3\theta) (1+k^2\sin^2\theta)^{-\frac{1}{2}} d\theta \end{aligned}$$

Since  $k = \frac{\mu r}{e}$  must be very small at the distance corresponding to the third shell, it is possible to

expand binomially, neglecting higher powers of  $(k \cdot \sin \theta)$ .

$$\begin{aligned} \therefore f &= \frac{n\mu}{r^3} \int_0^{\frac{\pi}{2}} (2\sin\theta \cos\theta - k\sin^3\theta) \left(1 - \frac{1}{2}k^2\sin^2\theta + \dots\right) d\theta \\ &= \frac{n\mu}{r^3} \left[ -k \cdot \frac{2}{3} + \frac{1}{2}k^3 \cdot \frac{4 \cdot 2}{5 \cdot 3} - \dots \right] \end{aligned}$$

Which approximates to

$$f = -\frac{2n\mu k}{3r^3} = -\frac{2n\mu F}{3re} \quad (6.10)$$

for small enough values of  $k$ .

The value of  $\mu$ , the average dipole moment of the solution, is given by the Langevin expression

$$\mu = \mu_0 \left( \coth \frac{\mu_0 e}{r^2 k T} - \frac{k T r^2}{\mu_0 e} \right) \quad (6.11)$$

which is a standard result (c.f. Ref 46,) obtained by allowing for the disorientation of dipoles in a field  $\frac{e_2}{r}$  by thermal agitation.  $k$  is Boltzmann's constant,  $T$  the absolute temperature and  $\mu_0$  the true dipole moment

of water. Using the accepted values of :

$$\begin{aligned} k &= 1.37 \times 10^{-16} \\ T &= 298^\circ \\ \mu_0 &= 1.87 \times 10^{-18} \text{ E.S.U.} \\ e &= 4.8 \times 10^{-10} \text{ E.S.U.} \end{aligned}$$

Substituting these values into equation (6.10), for  $r = 6 \text{ \AA.U.}$  we obtain

$$f = -0.035 n F. \quad (6.12).$$

This is the reaction field at 0 along OA, contributed by the  $n$  dipoles of the third shell, due to their rotation from radial positions by the action of the field  $F$  along OA. The total field on the ion is therefore

$$R = F(1 - 0.035 n). \quad (6.13)$$

Since a positive ion will always move in the direction of the external field, the reaction field can never exceed this, necessitating that  $n < \frac{1}{0.035}$ .

This fixes the upper limit on  $n$  as  $n_{\text{max}} = 28$  molecules. That means that there cannot be more than twenty-eight molecules in the third shell which can fully contribute to the reaction field on the ion. There could, however, be a greater number of molecules in the shell if screening by the inner two shells has diminished the actual contribution to the total field at the centre.

The reaction field has been calculated assuming a steady external applied field. If an alternating field is applied instead, the distortion from total radial alignment of the water dipoles will tend to follow the field at low frequencies. As the frequency increases, however, the inertia of the molecules will cause a phase-lag in the usual way, which can be represented, as shown by Debye (46) in his original theory, by the introduction of a term  $\frac{1}{(1 + \omega^2 \tau^2)}$  where  $\omega$  is the angular frequency, and  $\tau$  the relaxation time of the water molecules in the solution. Equation (6.13) is then modified to become

$$R_{\omega} = F \left( 1 - \frac{0.035n}{1 + \omega^2 \tau^2} \right) \quad (6.14)$$

where  $R_{\omega}$  is the total field on the ion in the direction of, and in phase with, the field  $F$  of angular frequency  $\omega$ . It is this force on the ion which results in the ionic conductivity of the solution, since the ion will move under the force in the direction determined by its charge.

For a steady field,

$$R_0 = F (1 - 0.035n)$$

Hence, the ratio of the low frequency conductivity to

the high frequency conductivity is given by :

$$\frac{\sigma_{\omega}}{\sigma_0} = \frac{R_{\omega}}{R_0} = \frac{(1 + \omega^2 \tau^2)^{-n} - 0.035n}{(1 + \omega^2 \tau^2)(1 - 0.035n)} \quad (6.15)$$

The most recent value for  $\tau$ , the relaxation time of potassium chloride solution, is given by Collie, Ritson and Hasted (35) who obtained a value corresponding to a relaxation wavelength of 1.4cm. for a solution of 2 Normal. At a frequency of  $3 \times 10^9$  c/s,

$$\omega \tau = .14$$

This is sufficiently close to the value for pure water, to be applicable at the concentrations used here, without incurring a great error.

Graph VI11 shows, that the percentage decrease in conductivity at the high frequency of the value at low frequencies is approximately 33% and can be taken to be the same over the entire range, within the limits of experimental error. Therefore, substituting into (6.15),

$$\frac{(\sigma_0 - \sigma_{\omega})_{100}}{\sigma_0} = 33\%$$

$$\therefore \frac{\sigma_{\omega}}{\sigma_0} = 1.49 = \frac{(1 + (.14)^2)^{-n} - 0.035n}{(1 + (.14)^2)(1 - 0.035n)} \quad (6.16)$$

Solving for the best integral value of  $n$  gives

$$n = 27.$$

Since the theory had assumed that, from physical considerations,  $n$  would lie between twenty-two and twenty-eight molecules, a value of  $n = 27$  from experimental data gives good support to the assumptions made initially.

On the present results, it is impossible to test the entire truth of the new theory, but it can be said that if the theory is valid, it would explain observed results, which no previous theory has done satisfactorily.

Some Predictions that can be made by Means of the New Theory.

1) Variation of Conductivity change with Frequency.

For a monovalent positive ion, it has been shown that the reaction field on the ion due to a shell of  $n$  dipoles at a distance  $r$  and acted on by an external field  $F$  of angular velocity  $\omega$  approximates to

$$R_{\omega} = F \left( 1 - \frac{\frac{2n\mu}{3re}}{1 + \omega^2 \tau^2} \right)$$

For more complex ions than occur in potassium chloride solution, there may be a multiple charge on the inner ion, the radius of the shells will be modified and the distribution may no longer be spherical. It is, however, to be expected, that at high frequencies an anomalous dispersion effect would occur as  $\omega\tau$  approaches unity. For instance, for potassium chloride, at a frequency of  $2.1 \times 10^{10}$  c/s., where  $\omega\tau = 1$ , and assuming  $n = 27$ , the ratio of low frequency conductivity to high frequency conductivity becomes about 9. No practical confirmation of this has been obtained yet, other than indirectly in the work of Gärtner (45), which has performed with high valency ions in glycerine. At a frequency comparable with the relaxation frequency for glycerine, and using magnesium sulphate as solute, she found an increase in conductivity of five times its

low frequency value, which is of the expected order of magnitude.

It appears that an investigation of monovalent ionic aqueous solutions at a frequency of 2000 megacycles would be profitable from the point of view of gaining corroboration for the theory. Subsequently, higher valency solutes in water could be used, and the theory extended to cover larger ions.

## 2) Variation of conductivity change with increasing concentration.

The foregoing calculations have depended on a high state of dilution, since no account has been taken of ionic interactions. At greater concentrations, the positive and negative ions can no longer be considered to be sufficiently separated so as not to affect each other, and the result is a "shell breaking" effect, as dipoles in the outer shell of one ion are affected by the vicinity of another. This has the effect of lessening the reaction field, causing a corresponding increase in ionic conductivity. Other effects, however, also come into play at high concentrations.  $\tau$  would increase due to the proximity of the other ions, and this would tend to move the anomalous dispersion to higher frequencies, so that the maximum conductivity decrease occurs at increasingly higher frequencies as the concentration is increased. Also the disymmetry and electrophoretic effects of the Debye-Hückel theory,



which are responsible for the Falkenhagen decrease in conductivity, though very small at high dilutions, are increasingly important at high concentrations. Association, as described by Bjerrum (42), also occurs at high concentrations and this would lead to a further decrease in conductivity.

It is difficult to assess the relative importance of all these effects. Experiment shows, however, that at very high concentrations, there is a linear decrease in the conductivity of strong electrolytes at low frequencies. The effect at high frequencies would be mainly due to the Falkenhagen dispersion, but this has been too small to detect in the results of previous workers (35).

### 3) The Variation of dielectric constant of saline solution with concentration.

One practically observable phenomenon that may be interpreted satisfactorily by the use of the model described in the foregoing discussion, is the variation of the low-frequency dielectric constant of saline solutions with concentration.

Measurements on aqueous solutions of potassium chloride were carried out by Pechhold (51), using a method of measuring the torque on a conducting ellipsoid suspended in the liquid originally due to Fürth (52). Unfortunately, the order of accuracy of Pechhold's results is not very high, while a far more sensitive modification of Fürth's

method, used by Milicka and Slama (53) was not applied to measurements on potassium chloride. Since, however, some of Pechhold's further measurements on sodium chloride and other salt solutions are everywhere confirmed by Milicka and Slama's more reliable results. It is reasonable to assume that for potassium chloride also, Pechhold's values are correct within the limits of scatter.

The general effect observed was, that for both potassium and sodium chlorides, the dielectric constants at first decreased with increasing concentration, falling to a minimum, and then increased to a value greater than that for pure water, apparently approaching limiting values at very high concentrations. The relationship found by Pechhold and Milicka and Slama between dielectric constant and concentration for potassium chloride and sodium chloride respectively, at the low concentration end of the range is shown in Graph LX.

A qualitative explanation of this behaviour is immediately obtained using the model described in the previous arguments. In the absence of any ions, water molecules will, due to their permanent dipole moment, tend to align in the presence of an applied external field, the only disruptive influence to complete alignment in the direction of the applied

GRAPH IX

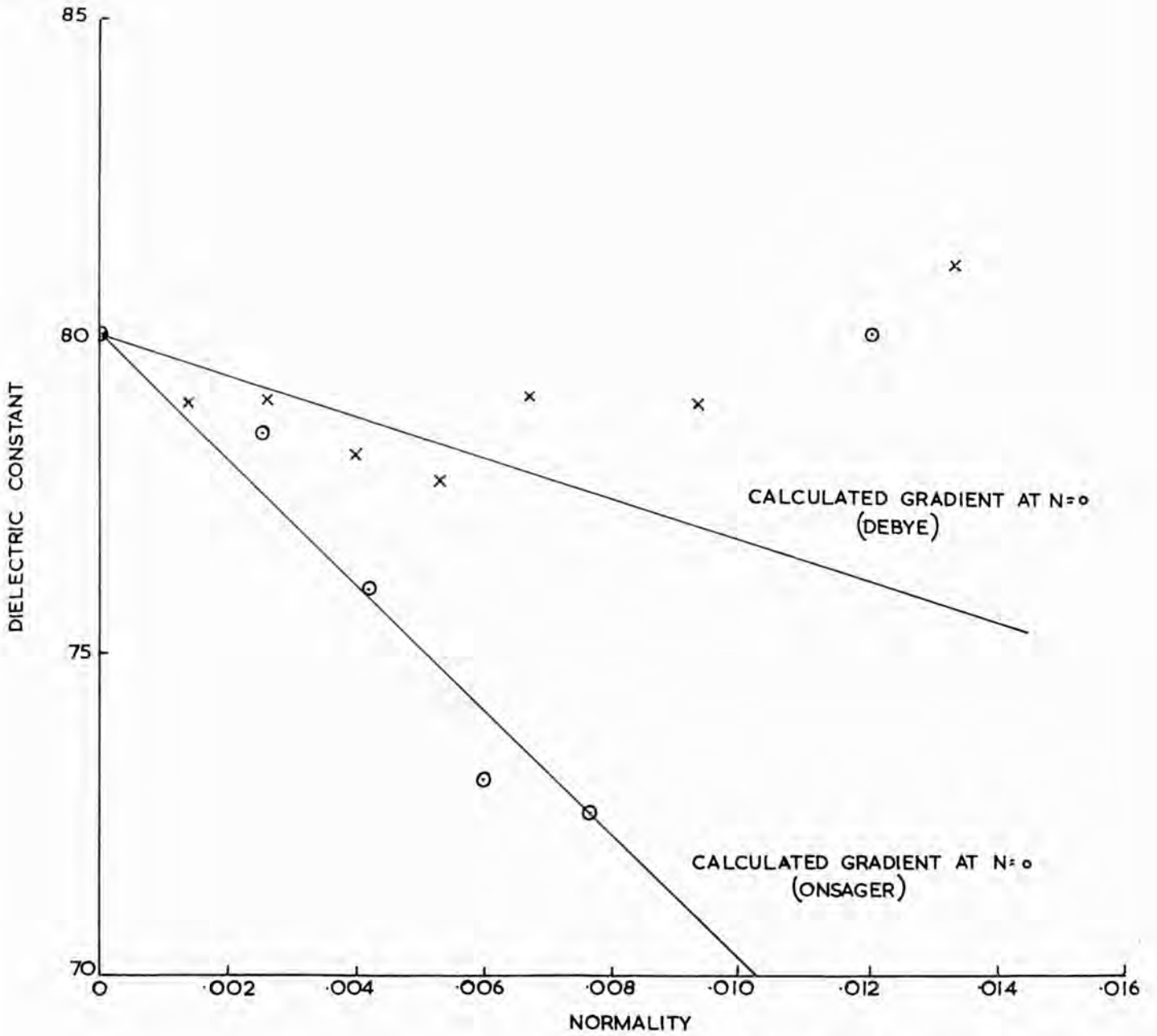

x ... PECHOLD'S RESULTS FOR KCl  
o ... MILICKA AND SLAMA'S RESULTS FOR NaCl

field being the thermal agitation of the molecules themselves. In the presence of an ion of either sign, the dipoles in the immediate neighbourhood of the ion are radially aligned due to the field of the ion, and, on the application of the external field, can take less part in the polarisation of the surrounding medium. Thus, in the region of extreme dilution, where inter-ionic forces can be neglected, the addition of more ions has the effect of binding more water dipoles, which then play a diminished part in the polarisation of the medium with a consequent decrease in the dielectric constant. This would account for the initial negative slope of the dielectric constant - concentration curve.

As the concentration increases, a point must be reached when the oppositely charged ions begin to affect each other. Fürth interpreted the subsequent rise in dielectric constant by the suggestion that the ions and their associated molecules form 'ionic complexes' which are themselves dipoles and thus contribute to an overall increase of the dielectric constant. A new theory for the behaviour at higher concentrations of various ionic solutions is in the process of publication (Little, 1955)

In order to test the validity of the assumptions made, it is interesting to compare quantitatively the decrease in dielectric constant calculable on the basis

of the model of Fig.7. with measured results at the low concentration end. Using the same notation as before, we again consider a dipole at P (Fig.7) situated at a distance  $r$  from the ion at O.

The component of the dipole moment in the direction of the external field is given by

$$m_{oA} = \mu_o \cos(\theta - \phi) \quad (6.17)$$

where  $\mu_o$  is the dipole moment. It is assumed that in the immediate vicinity of the ion, the field on the dipole is so strong that any disalignment due to thermal agitation is negligible.

If there are  $n$  dipoles per unit area of the shell of which P is part, and again postulating that there are a sufficient number of dipoles to justify integration over a uniform spherical distribution, the effective moment of the whole shell in the direction of the applied field will be

$$\begin{aligned} M_{oA} &= \int_0^\pi 2\pi r^2 n \sin\theta \, d\theta \cdot \mu_o \cos(\theta - \phi) \\ &= 2\pi r^2 n \mu_o \int_0^\pi \sin\theta (\cos\theta \cos\phi - \sin\theta \sin\phi) \, d\theta \end{aligned}$$

Substituting for  $\phi$  from (6.5), the expression for the total moment of the shell becomes :

$$M_{0n} = 2\pi r^2 n \mu_0 \int_0^\pi \left\{ \frac{\sin\theta \cos\theta}{\sqrt{1+k^2\sin^2\theta}} - \frac{k \sin^3\theta}{\sqrt{1+k^2\sin^2\theta}} \right\} d\theta \quad (6.18)$$

$$\therefore M_{0n} \approx 2\pi r^2 n \mu_0 \left[ \frac{2k}{3} + \dots \right]$$

neglecting higher orders of  $k$ .

If  $N$  is the total number of dipoles in the shell,

$$N = 4\pi r^2 n$$

$$\therefore M_{0n} = \frac{2N\mu_0 k}{3} = \frac{2N\mu_0 r^2 F}{3e} \quad (6.19)$$

This is the contribution to the electric moment of the liquid made by the shell at a distance  $r$  from the centre of the ion. In order to estimate the consequent decrease in the dielectric constant, it is necessary to determine the contribution to the electric moment of the molecules forming the shell in the case when no ion is present, and to use a formula connecting the electric moment with the dielectric constant.

The simplest relationship between the dielectric constant of a medium and the properties of its individual molecules (where the latter are permanent dipoles) is that due to Debye. The original Debye formula was calculated

for polar gases, in which it may be assumed that the intermolecular forces are negligible, but it may also be applied with some success to very dilute solutions of polar liquids in a non-polar solvent. The application of Debye's formula to the case of pure polar liquids such as water, clearly oversteps its range of validity, and leads to erroneous predictions, such as an electrical Curie point for water at ordinary temperatures. A full account of the derivation of Debye's formula is given in his book (46) the final form of the relationships obtained being :

$$P = n\bar{m} = n\left(\alpha_0 + \frac{\mu_0^2}{3kT}\right)F \quad (6.20)$$

where  $P$  is the moment per unit volume,  $n$  the number of dipoles per cc. and  $\bar{m}$  the average contribution to the total moment of one dipole, which consists of the component due to the permanent polarisation,  $\frac{\mu_0^2 F}{3kT}$ , and the part induced by the field  $F$  on the dipole,  $\alpha_0 F$ .

Debye himself recognised that the theory could not be applied to pure polar liquids without modification to account for the effect on  $F$ , the field acting on the ion when a field  $E$  is applied externally, of the contribution due to neighbouring dipoles. He therefore introduced a "hindering energy" theory (54) retaining

the basic Clausius-Mosotti formula and introducing an energy restricting the free rotation of molecules in a semi empirical way. The new theory certainly eliminated the difficulty of Curie points, but had the disadvantage of introducing a new entity, the hindering effect, which cannot be determined by an independent experiment, and thus makes it impossible to produce absolute proof of the theory.

Onsager (55) used a different model, comprising of a central molecule in a sphere of uniform refractive index  $n$ , with a permanent dipole situated at the centre. This dipole is assumed to have a moment  $\mu_0$ , being the same as the dipole moment of the vapour state. The sphere is surrounded by the medium of dielectric constant  $\epsilon$ , a smoothed value being used to account for the effect of the surrounding molecules. The basic difference between the Debye and Onsager models is the fact that Onsager's cavity contains a single molecule, surrounded by a region of dielectric constant derived from the optical refractive index, whereas Debye's cavity is large enough to include a sufficient number of molecules so that outside the cavity they produce a Mosotti field, while within the cavity, the averaged effect on the central dipole is zero. Onsager states that this averaging process is not permissible, and introduces a reaction field due to the effect of



the dipole in the cavity on the surrounding molecules. He obtains a value for the polarisation given by :

$$\bar{n}m = n \left[ \frac{\mu_0^2 (n^2 + 2)^2 (2\varepsilon + 1) \varepsilon}{9(2\varepsilon + n^2) kT} + \frac{\varepsilon (n^2 - 1) a^3}{(2\varepsilon + n^2)} \right] F \quad (6.21)$$

Van Vleck (56), in a critical comparison of the Debye and Onsager formulae, comes to the following conclusion:

On first sight, the Onsager model should be the more accurate, as it allows the surroundings of a molecule to adjust themselves to the latter's rotation. But the average period of a molecule's free rotation is short compared with the relaxation time of the dielectric. If, therefore, the rotations are so rapid that the surrounding molecules cannot follow, the Debye formula would be more accurate. The implication is, thus, that at zero frequency (which is at present under consideration), Onsager's formula should give a better representation of dielectric behaviour.

For completeness, it is necessary to add that Kirkwood (57) gives a quite general theory, not based on a specific model of liquid structure. He uses statistical mechanics to relate the dielectric constant to the dipole moment and total polarisation induced as a result of hindered relative molecular

rotations by a representative molecule in a spherical region of radius large compared with intermolecular forces. His result, though containing no limiting assumptions, is obtained in a form requiring for its complete interpretation, a detailed theory of liquid state.

For comparison purposes, the initial depressions of the dielectric constant with increase in concentration will be calculated using both the theories of Debye and Onsager.

Using the previous model of a monovalent ion surrounded by three shells of rigidly aligned water molecules, with the following distribution :

<u>Shell No.</u>	<u>Radius r</u>	<u>Number of aligned dipoles N.</u>
1	2 Å.U.	4
2	4 "	12
3	6 "	27

From Equation (6.19), the contribution to the total polarisation due to the dipoles surrounding a single ion is

$$\begin{aligned}
 M_{0A} &= \frac{2\mu_0}{3e} \left[ \sum_1^3 N r^2 \right] F \\
 &= \frac{2\mu_0}{3e} \left[ 4 \times 4 + 12 \times 16 + 27 \times 36 \right] 10^{-16} F
 \end{aligned}
 \tag{6.22}$$

Since, according to Debye, before the addition of the ion, the water molecules would have contributed to the total polarisation by an amount given by (6.20), the change in the contribution to the polarisation caused by a single ion is

$$\Delta P = \left[ \frac{2\mu_0}{3e} \times 1180 \times 10^{-16} - (4+2+27) \frac{\mu_0^2}{3kT} \right] F \quad (6.23)$$

neglecting the contribution due to the induced moment compared with that of the permanent moment, which is permissible for water molecules, since  $\alpha_0 \ll \frac{\mu_0^2}{3kT}$

In the case of sodium and potassium chloride solutions, the individual positive and negative ions are very similar in size and both are univalent and will, on the whole, tend to bind the same number of water molecules, (the opposite sign of the charge only affecting the direction the dipole aligns itself along the radius vector). A factor 2 is therefore introduced to account for the effect of both positive and negative ions on the dielectric constant. In one litre of Normal solution, there are  $6.03 \times 10^{24}$  molecules (Avogadro's Number). Hence, in lcc. of N Normal solution, there are  $2N \times 6.03 \times 10^{20}$  ions of each kind.

$$\therefore P - P_0 = (N - N_0) 2 \times 6.03 \times 10^{20} \left[ -\frac{2\mu_0}{3e} \times 1180 \times 10^{-16} + \frac{43\mu_0^2}{3kT} \right] F$$

Where P is the polarisation at a concentration N,

and  $P_0$  the corresponding polarisation at the normality  $N_0 = 0$ . If only very dilute solutions are considered, this may be treated as a differential, giving the variation of polarisation with concentration at the origin of a corresponding curve.

Taking

$$\mu_0 = 1.8 \times 10^{-18}$$

$$k = 1.38 \times 10^{-16}$$

$$T = 300^\circ \text{ Abs.}$$

$$e = 4.8 \times 10^{-10} \text{ E.S.U.}$$

$$\therefore \frac{dP}{dN} = 2 \times 6.03 \times 10^{20} \left[ \frac{2 \times 1.8 \times 10^{-18} \times 1180 \times 10^{-16}}{3 \times 4.8 \times 10^{-10}} - \frac{43 \times 1.8 \times 1.8 \times 10^{-36}}{3 \times 300 \times 1.38 \times 10^{-16}} \right] F$$

$$= -0.985 F$$

Also, since the fundamental relationship between the externally applied field,  $E$ , and the resultant polarisation  $P$  is given by :

$$\frac{4\pi P}{E} = \epsilon - 1 \quad (6.24)$$

where  $\epsilon$  is the dielectric constant,

$$\therefore \frac{d\epsilon}{dN} = \frac{4\pi}{E} \cdot \frac{dP}{dN}$$

(6.4) shows that

$$F = E + \frac{4}{3}\pi P$$

$$\therefore F = E \left( \frac{\epsilon + 2}{3} \right) \quad (6.25)$$

Since the total decrement in  $\epsilon$  is very small over the region considered, it is possible to write :

$$\frac{d\epsilon}{dN} = \frac{4\pi}{E} \cdot \frac{dP}{dN} = \frac{4\pi(\epsilon+2)}{3F} [-0.985] F \quad (6.26)$$

$$\text{If } \epsilon = 80$$

$$\therefore \frac{d\epsilon}{dN} = -340$$

This is the predicted slope at the origin of the graph of dielectric constant variation with concentration, calculated from an assumption of Debye's theory and using the new model of ion-dipole interaction. In order to obtain a value for the same slope on the basis of Onsager's theory, (55), it must be assumed that the forty-three dipoles held aligned by the central ion would originally have contributed to the total polarisation by an amount

$$m_0 = 43 \left[ \frac{\mu_0^2 (n^2 + 2)^2 (2\epsilon + 1)\epsilon}{9(2\epsilon + n^2)^2 RT} + \frac{\epsilon (n^2 - 1) a^3}{(2\epsilon + n^2)} \right]$$

where  $n$  is given by the refractive index, 1.33, and  $a$  is the radius of a water molecule.

Also it has been shown that after the introduction of the ion, the water molecules formed a dipole of

moment

$$m = \frac{2\mu_0 F}{3e} \sum nr^2$$

$$= 2.95 \times 10^{-24} F$$

Onsager shows that a dipole of moment  $\mu_0$  in the medium would have an effective moment  $\mu_0 \frac{(n^2 + 2)(2\varepsilon + 1)}{3(2 + n^2)}$

owing to the effect of the surrounding medium. Thus, the addition of one ion to the solution has changed the moment by an amount :

$$(a^3 = 7.12 \times 10^{-24} \text{ cm}^3)$$

$$\Delta m = F \left[ \frac{2.95 \times 10^{-24} (n^2 + 2)(2\varepsilon + 1)}{3(2 + n^2)} - \frac{43 \times 1.8^2 \times 3.77^2 \times 161 \times 80 \times 10^{-20}}{(9 \times 161.8^2) \times (300 \times 1.38)} - \frac{80 \times 7.7 \times 7.12 \times 10^{-24}}{161.8} \right]$$

$$\therefore \Delta m = -24.0 \times 10^{-22} F$$

$$\therefore \frac{dP}{dN} = 2 \times 6.03 \times 10^{20} (-24.0 \times 10^{-22}) F$$

$$\therefore \frac{d\varepsilon}{dN} = \frac{4\pi}{3F} \times 82 \times (-2.9) F$$

$$\therefore \frac{d\varepsilon}{dN} = -990.$$

---



---

Hence, for an ionic aqueous solution, in which both types of ions are monovalent and of approximately the same size, the new model of ion-dipole interaction leads to a prediction that the gradient of a graph of dielectric constant against concentration at the origin should be either -340 or -990 according to whether Debye's formula or Onsager's formula is used.

Graph LX shows how this prediction agrees with actual results. The large scatter, incurred due to insensitivity of apparatus, of Fehhold's results for potassium chloride makes it impossible to state more than that the gradient is of the right order of magnitude. The more reliable data of Milicka and Slama shows a very good fit, if Onsager's theory is used. Since at zero frequency, the use of Onsager's theory rather than Debye's is generally advocated, the prediction appears successful, thus providing an indirect check on the principles applied in the model of dipole behaviour at low concentrations.

Summary.

Originally, the problem was to investigate the behaviour of very dilute solutions when subjected to Ultra High Frequency radiation. The differential method evolved was sufficiently sensitive to show that the theory of Falkenhagen, which had not previously been investigated at these frequencies, did not give a complete explanation of the results obtained. To interpret these results, a new theory was evolved, introducing a relaxation phenomenon in the solvent due to the ionic binding of water molecules.

Quantitative calculations, using a very simple model of radially disposed water molecules forming three shells about the ions, led to fair agreement with X-ray data on water structure, proving that the model represented a possible state of affairs. Though rigid proof of the validity of the new theory cannot be obtained until the method has been applied to a large number of salts of various valencies and at much higher frequencies, a test of the model has been made by applying it to interpret data found by other workers in the completely different field of D.C. dielectric constant measurements. The fact that both quantitatively and qualitatively the predictions were successful serves in some measure to justify the assumptions made.



APPENDIX 1.Theory of the Phase-Changing Device.

It was desired to produce a signal of constant amplitude but variable phase from a given input signal - in this case the wavemeter output signal. For this purpose, the signal was first split into two components, one twice the amplitude of the other and  $\pi$  out of phase with it. This was achieved by suitable choice of the anode and cathode loads,  $R_{14}$  and  $R_{15}$ , of the triode-splitter  $V_4$  shown in Figure 5.

Let the two signals on the anode and cathode of the first part of  $V_4$  be of amplitude  $E$  and  $2E$  respectively. The latter was passed into an R-C filter consisting of the variable resistance  $R_{16}$  and the variable capacitance  $C_3$ . This arrangement is shown in Figure 8.(i)

Then, from the theory of the A.C.network, if  $V$  represents the voltage across the capacitance  $C_3$ ,

$$\begin{aligned}
 V &= \frac{\left(\frac{1}{C_3 j\omega}\right) \cdot 2E}{\left[R_{16} + \frac{1}{C_3 j\omega}\right]} \\
 &= \frac{2E(1 - j R_{16} C_3 \omega)}{(R_{16}^2 C_3^2 \omega^2 + 1)} \quad (A.1)
 \end{aligned}$$

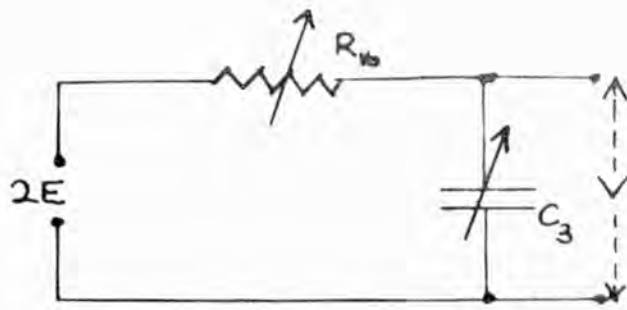

(i).

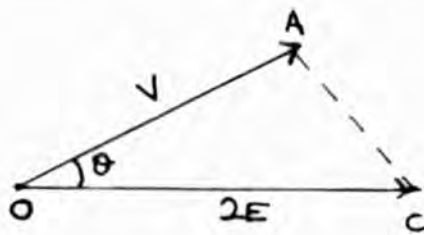

(ii)

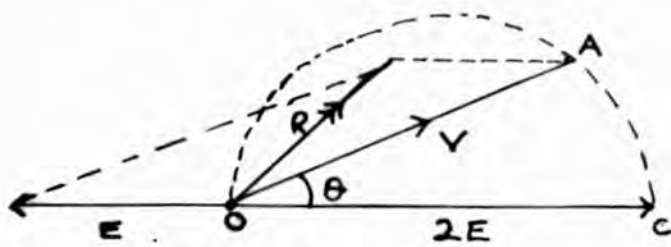

(iii)

Fig. 8.

Let  $R$  and  $C$  be the values of  $R_{16}$  and  $C_3$  respectively at any time. (A.1) represents a voltage of amplitude  $2E / \sqrt{1 + R^2 C^2 \omega^2}$  and at a phase angle  $\theta = \tan^{-1}(-RC\omega)$  with  $2E$ .

Since both  $R_{16}$  and  $C_3$  are variable, the voltage output  $V$  across the capacitance can be represented graphically by a vector of length  $V = \frac{2E}{\sqrt{1 + R^2 C^2 \omega^2}}$  at an angle  $\theta = \tan^{-1}(-RC\omega)$  with the input voltage  $2E$ . This is shown in Fig. 8.(ii).

In particular, when  $\theta = 0$ ,  $R = 0$  or  $C = 0$ , and then  $V = 2E$ . When  $R = \infty$  or  $C = \infty$ ,  $\theta = \pi/2$  and then  $V = 0$ .

Also,  $\cos \theta$ , from the definition of  $\theta$ , equals  $\frac{1}{\sqrt{1 + R^2 \omega^2 C^2}}$ .  
But from 7 (ii) it is clear that as

$$\frac{V}{2E} = \frac{1}{\sqrt{1 + R^2 \omega^2 C^2}} = \cos \theta, \quad (\text{A.2})$$

$\therefore \angle OAC = 90^\circ$ .

This means that the locus of A, the end of vector  $V$ , lies on a semicircle of diameter  $2E$  (represented by  $OC$ ), as either  $R$  or  $C$  is varied from  $0$  to  $\infty$ .

The voltage across  $C_3$  was therefore variable both in phase and in amplitude, with ranges  $0$  to  $\pi/2$  and  $0$  to  $2E$  respectively. This variable voltage was fed through a cathode follower (the second half of the double-triode  $V_4$  is Fig. 5) to enable the output to be fed from a low impedance source into the high

resistance  $R_{20}$  of the adding circuit.

The second signal, from the anode of the splitter, of fixed amplitude  $E$ , was passed via the high resistance  $R_{19}$  ( $R_{19} = R_{20} = 100K$  ohms) into the full-feedback adding circuit consisting of the valves  $V_5$  and  $V_6$ . In this circuit, the two signals were added without any change to their amplitudes and phases. (Fig.5).

Since the vector  $E$  was originally  $\pi$  out of phase with the vector  $2E$ , and  $V$  was  $\tan^{-1}(-RC\omega)$  out of phase with  $2E$ , the phase angle between  $E$  and  $V$  must be

$$\phi = (\pi - \tan^{-1}(-RC\omega)) - (\pi - \theta). \quad (A.3)$$

Vectorially, the addition of  $E$  and  $V$  is represented by Fig.8 (iii). The resultant of the addition must be the voltage  $R$ .

Solving for  $R$

$$R^2 = E^2 + V^2 - 2EV \cos \theta. \quad (A.4)$$

But  $V = \frac{2E}{\sqrt{1+R^2C^2\omega^2}}$ ,

$$\cos \theta = \frac{1}{\sqrt{1+R^2C^2\omega^2}},$$

$$\therefore R^2 = E^2 + \frac{4E^2}{1+R^2C^2\omega^2} - \frac{2E \cdot 2E}{1+R^2C^2\omega^2}$$

$$\therefore R = E. \quad (A.5)$$

Hence, the resultant of the vector addition is a vector of fixed amplitude,  $E$ , at an angle  $\phi = \pi - \theta$  with the voltage  $E$ . Since, as  $R$  and  $C$  are varied,  $\theta$  varies from 0 to  $\frac{\pi}{2}$ , this is the phase shift that can be imposed on the output voltage without any change in amplitude.

APPENDIX 11.Transmission Line Theory.

The equations used in Chapter 1V, governing the transmission of electro-magnetic waves along a system of parallel lines, will, for completeness, be derived below.

Consider a voltage wave travelling along a transmission line consisting of parallel conductors, one of which may be assumed at earth. If the wave is travelling in a direction OZ with respect to some arbitrary point of origin on the line, the voltage at any other point at a distance  $z$  from 0 is represented by

$$V_1 = V_0 e^{Pz} \quad (\text{A.6})$$

where  $P$  is the propagation constant of the line and  $V_0$  the voltage at the origin  $z = 0$ .  $P$  is a function of the dimension of the line and the nature of the dielectric separating the two conductors. If  $z_0$  is the characteristic impedance of the line, the current  $i_1$  associated with the voltage  $V_1$  is, by definition of  $z_0$ , given by:

$$i_1 = V_1 / z_0. \quad (\text{A.7})$$

If the line is terminated at any point, the termination will, in general, give rise to a reflected wave of the form

$$V_2 = r V_0 e^{-Pz} \quad (\text{A.8})$$

travelling in the opposite direction.  $r$  is the reflection coefficient of the termination, and is generally a complex quantity, which can be written

$$r = r_0 e^{j\phi}$$

where  $r_0$  is wholly real, and  $\phi$  is the phase constant associated with the reflected wave.

Since the origin can be placed anywhere, the termination may be taken at  $z = 0$ . The wave at a distance  $x$  from the origin will have an amplitude

$$\begin{aligned} V_x &= V_1 + V_2 \\ &= V_0 ( e^{Px} + r_0 e^{-Px} e^{j\phi} ) \end{aligned} \quad (\text{A.9})$$

Similarly, the current at this point will be given by :

$$i_x = 1/z_0 \cdot (V_1 - V_2)$$

The impedance of the line at a distance  $x$  from the origin is therefore given by

$$\begin{aligned} Z_x &= \frac{V_x}{i_x} = \frac{Z_0 (V_1 + V_2)}{(V_1 - V_2)} \\ &= Z_0 \frac{\begin{pmatrix} P_x & -P_x & j\phi \\ e & +r_0 e & e \end{pmatrix}}{\begin{pmatrix} P_x & -P_x & j\phi \\ e & -r_0 e & e \end{pmatrix}} \end{aligned} \quad (\text{A.10})$$

At the termination,  $x = 0$ , and the terminating

impedance of the line is therefore

$$Z_T = Z_0 \left( \frac{1 + r_0 e^{j\phi}}{1 - r_0 e^{j\phi}} \right) \quad (\text{A.11})$$

Hence, if  $r_0$  and  $\phi$  can be measured, and  $Z_0$  is known for the particular line, the terminating impedance can be calculated using Equation (A.11). This is the technique used in several of the methods for the absolute measurement of dielectric constants described in Chapter 1. Also, eliminating  $r_0 e^{j\phi}$  between equations (A.10) and (A.11), leads to the relationship

$$r_0 e^{j\phi} = \frac{Z_T - Z_0}{Z_T + Z_0}$$

$$\therefore Z_x = Z_0 \left[ \frac{Z_T \cosh Px + Z_0 \sinh Px}{Z_T \sinh Px + Z_0 \cosh Px} \right] \quad (\text{A.12})$$

which is the input impedance presented by a line of length  $x$  and propagation constant  $P$ .

$P$  is generally a complex quantity and can be represented by  $P = (\alpha + j\beta)$ . Substituting this value into (A.12),

$$Z_x = Z_0 \left[ \frac{Z_T \cosh(\alpha + j\beta)x + Z_0 \sinh(\alpha + j\beta)x}{Z_T \sinh(\alpha + j\beta)x + Z_0 \cosh(\alpha + j\beta)x} \right]$$



This is the most general expression for the input impedance to a transmission line of characteristic impedance  $z_0$  at a distance  $x$  from a termination of terminal impedance  $z_T$ .

This is the equation that has been used on Page 54 for the evaluation of the input impedance at resonance of the equivalent line analogue of the tuned cavity.

REFERENCES.

- (1) Drude; Wied. Ann. 54, 352, 1895,  
       "      "   58,  1,  1896,  
       "      "   58, 17, 1896,  
       Zeit. Phys. Chem. 23, 267, 1897,  
       Wied. Ann. 61, 466, 1897.
- (2) Willis Jackson; 'High Frequency Transmission Lines',  
       (Methuen) p.64-5.
- (3) Tear; Phys. Rev. 21, 611, 1923.
- (4) Esau & Bätz, Phys. Zeit. 38, 774, 1937.  
       Bätz, "      "      40, 394, 1939.
- (5) Von Ardenne, Groos & Otterbein, Phys. Zeit.37, 533, 1936.
- (6) Knerr, Phys. Rev. 52, 1054, 1937.
- (7) Kebbel, Zeit. für Hochfrequenztechnik u. Elektroakust 53,  
       81, 1939.
- (8) Slevogt, Ann. der Phys., 141, 1939.
- (9) Roberts & Von Hippel, Phys. Rev. 57, 1056A, 1940.  
       J. App.Phys. 17, 610, 1946.
- (10) Collie, Ritson & Hasted, Trans. Far, Soc.42A,129, 1946.
- (11) Collie, Ritson & Hasted, Proc. Phys. Soc.40, 145, 1948.
- (12) Buchanan, J. I. E. E. 111, 58, 1952.
- (13) Little, Proc. Phys. Soc.B, 66, 175, 1953.
- (14) Saxton & Lane, Proc. Roy.Soc.A, 213,400,1952.
- (15) Flint & Williams, Phil. Mag.Sec. 7, 32, 489, 1941.
- (16) Saxton & Lane, 'Meteorological Factors in Radio Wave  
       Propagation', The Phys. Soc.1946,p.278.
- (17) Hartshorn & Ward, J. I. E.E. 79, 597, 1936.



- (38) McKenna, 'Theoretical Electrochemistry',  
(Macmillan & Co) 1939.
- (39) Debye & Hückel, Phys. Z. 24, 305, 1923.
- (40) Onsager, Phys. Z. 27, 388, 1926. Also Ibid, 28, 277, 1927.
- (41) Fuoss, Chem. Rev. 17, 27, 1935.
- (42) Bjerrum, Kgl. Danske Videnskabs Sels. 7, 9, 1926.  
Ergeb. Exack. Nat. 6. 125, 1926.
- (43) Debye & Falkenhagen, Z. Electchem. 34, 562, 1928.  
Phys. Z. 28, 836, 1927.
- (44) F. Domanic, Private Communication.
- (45) Gärtner, Phys. Z. 32, 919, 1931.
- (46) Debye, 'Polar Molecules', The Chemical Catalog. Co. Inc.,  
New York. 1929.
- (47) Bernal & Fowler, J. Chem. Phys. 1, 515, 1933.
- (48) Pople, Proc. Roy. Soc. A, 205, 163, 1951.
- (49) Katzoff, J. Chem. Phys. 2, 814, 1934.
- (50) Morgan & Warren, J. Chem. Phys. 6, 666, 1938.
- (51) Pechhold, Ann. d. Phys. 83, 427, 1927.
- (52) Fürth, Phys. Z. 32, 184, 1931.
- (53) Milicka and Slama, Ann der Phys., V, 8, 663, 1931.
- (54) Debye, Phys. Z. 36, 100, 193, 1935.  
Debye & Ramm, Ann. Phys. 28, 28, 1937.
- (55) Onsager, J. Amer. Chem. Soc. 58, 1486, 1936.
- (56) Van Vleck, J. Chem. Phys. 5, 556, 1937.
- (57) Kirkwood, J. Chem. Phys. 7, 911, 1939.

REPRINTED FROM THE  
PROCEEDINGS OF THE PHYSICAL SOCIETY, B, VOL. LXVIII, p. 65, 1955  
*All Rights Reserved*  
PRINTED IN GREAT BRITAIN

## The Ionic Conductivity of Dilute Potassium Chloride Solutions at Centimetric Wavelengths

By V. I. LITTLE AND V. SMITH  
Bedford College, University of London

*MS. received 21st September 1954 and in final form 10th November 1954*

*Abstract.* A differential method is described for measuring the ionic conductivity of potassium chloride solutions at  $3 \times 10^9$  c/s. The results reveal that a strong dispersion region exists at concentrations below 0.5 normal, which may be explained in terms of the perturbations by the applied field of a shell of water molecules surrounding the ion at a mean distance of 6 Å.

### § 1. INTRODUCTION

IN the dipolar relaxation part of the frequency range, the variation with frequency (if any) of the ionic part of the conductivity of salt solutions is masked by the large apparent conductivity contributed by the dipoles of the solvent. The most detailed work published recently on the electrical properties of aqueous ionic solutions at  $3 \times 10^9$  c/s and above has been that of Collie, Ritson and Hasted (1948) and Saxton and Lane (1952). These researches were most concerned, however, with the effect of the dissolved ions on the relaxation time of the solvent molecules. The smallest concentration of potassium chloride investigated was 0.5 normal, and it was convincingly demonstrated that the value of the ionic conductivity at this concentration, and for 1.0 normal, was almost certainly the same as the value at low frequency.

The present paper deals with an attempt to investigate the ionic conductivity effects of potassium chloride solutions in the concentration range 0.005 to 1.0 normal, in order to discover whether the relaxation process in the solvent could cause them to vary from their low-frequency value.

### § 2. DESCRIPTION AND THEORY OF THE APPARATUS

The apparatus was designed to measure directly the difference in total conductivity between the solution under investigation and distilled water. As it was desirable to concentrate only upon conductivity changes, it was essential that the apparatus be insensitive to the changes in dielectric constant. It was decided that an  $H_{011}$  rectangular cavity with a small bore quartz tube in contact with the centre of one wall and parallel to the electric field, would be suitable. The changes in output of the cavity as distilled water and salt solution were passed alternately through the tube were interpreted in terms of conductivity changes.

A simplified sketch of the apparatus is shown in figure 1. The two liquids to be compared were passed through a temperature equalizer into a specially designed two-way tap which was driven through reduction gearing at 1 cycle in eight seconds by a constant speed motor. During one cycle of the tap, water flowed for three seconds, all flow ceased for one second, and then the solution flowed for three seconds followed by another waiting period of one second.

A chemical analysis of the last fraction of the outflowing liquids showed that under these circumstances, a complete substitution of the liquids in the tube was taking place. The temperature of the outflowing liquids was measured by means of a thermocouple, and another was used to monitor the temperature difference between the liquids just before they entered the tap.

A CV234 valve oscillator, amplitude modulated at 4330 c/s, and provided with two outputs, was used as a signal source tuned to a frequency of  $3 \times 10^9$  c/s. Figure 2 gives a block diagram of the apparatus. The modulated signal was very loosely coupled to the  $H_{011}$  cavity, having passed through 10 dB of SAL. 1 type

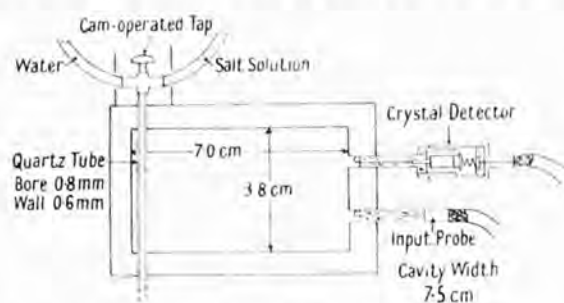

Figure 1. Cross section of  $H_{011}$  cavity for 10 cm waves.

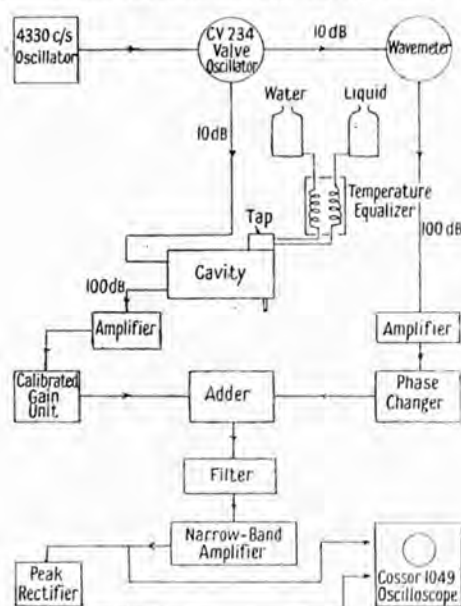

Figure 2. Block diagram of apparatus.

attenuating cable. An N.P.L. type cavity wavemeter was similarly coupled to the other oscillator output. The loosely coupled crystal detectors of both the  $H_{011}$  cavity and the wavemeter were connected through 100 dB of SAL. 2 type attenuating cable to two independent amplifiers, each of gain 100. The output of the wavemeter amplifier was passed through a circuit in which its phase could be varied continuously through  $180^\circ$  independently of its amplitude. It was then added electronically to the amplified  $H_{011}$  cavity signal, provision being made, by means of a variable resistance which could be switched in electrically, to vary the amplitude of this signal suddenly by a known small fraction.

The phasing unit was adjusted so that the wavemeter signal was in exact opposition to the cavity signal. The purpose of this arrangement was to increase

the effective percentage modulation imposed on the 4330 c/s signal by the interchange of the liquids in the cavity tube. The change in level of the cavity signal when 0.005 normal solutions were under investigation was much less than 1%, but by using the above device the signal eventually fed to the high gain amplifiers could be converted to one effectively modulated to a depth of 50% or more. After passing through the adding unit, the signal was filtered in an inductance-capacity filter circuit, to remove most of the harmonic terms originating in the square law crystal detectors. Further amplification in a narrow-band amplifier of gain  $10^4$  was followed by peak rectification resulting in a signal fluctuating at the tap frequency. This signal was displayed on a Cossor model 1049 oscilloscope, together with the 4330 c/s signal, before final rectification. The latter signal was used for monitoring and tuning purposes.

When dealing with low concentrations, the ratio of the change in signal to the signal corresponding to distilled water in the cavity tube, could be obtained

Resistances R	
1, 2, 9, 10, 23, 24, 29, 30	750 k $\Omega$
5, 6, 14, 15, 18, 22, 27, 28, 34, 35, 36	22 k $\Omega$
12, 13, 20, 21, 32	$150 \text{ k}\Omega \pm 1\%$
4, 8, 25, 31, 42, 44	220 k $\Omega$
3, 7, 26, 33	2.2 k $\Omega$
39, 40	2 k $\Omega$
41	2 M $\Omega$
43	10 k $\Omega$
16	$\frac{1}{2}$ M $\Omega$ variable
19	300 k $\Omega$
11	50 k $\Omega$ and 10 k $\Omega$ calibrated.
Condensers C	
1, 2, 4, 5, 6, 7	0.1 $\mu\text{F}$
8, 9, 10	0.01 $\mu\text{F}$
11	50 $\mu\text{F}$
3	0.0003 $\mu\text{F}$ variable.

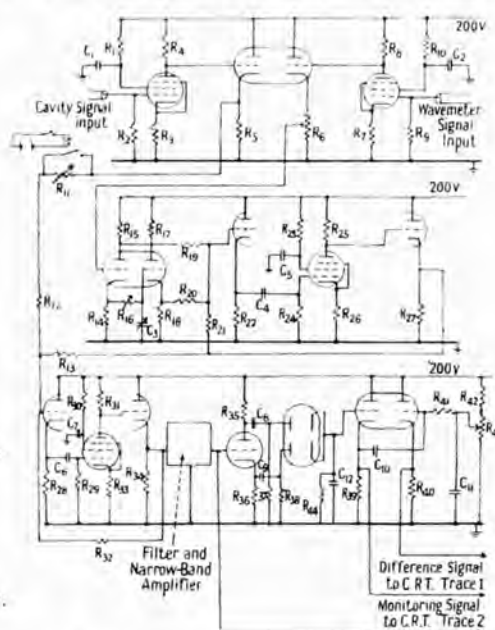

Figure 3. Circuit diagram of apparatus.

directly from the calibrated variable resistance included in the cavity signal line of the adding unit. The observed variations on the oscilloscope were cancelled by altering the amount of cavity signal fed to the adding unit by means of the calibrated control, and switching this in and out in antiphase with the observed change until no change in output signal level could be detected. The essential parts of this circuit will be found in figure 3.

### § 3. CALCULATION OF THE APPARATUS RESPONSE TO CHANGE IN IONIC CONDUCTIVITY

Use is made of a transmission line analogue for the purpose of calculating the response of the  $H_{011}$  cavity to changes in the conductivity of the liquid in the quartz tube.

Figure 4 represents a short circuited transmission line of characteristic impedance  $Z_0$ , with a condenser of capacity  $C$  situated a short distance  $l$  from the short-circuit. At a distance  $L$  from this condenser, the line is driven by a low

impedance source of e.m.f.  $E$  connected in series to represent the loose coupling to the oscillator.



Figure 4. Equivalent line.

The capacity  $C$  may be written

$$C = C_1 - jC_2 \quad \dots\dots (1)$$

where  $C_1 = C_3 + C_0\epsilon'$  and  $C_2 = C_0\epsilon''$ ,  $C_3$  being the contribution due to the quartz tube,  $C_0\epsilon'$  the contribution due to the real part of the dielectric constant of the liquid, and  $C_0\epsilon''$  that due to the imaginary part.

The terminating impedance of the driven line at distance  $l$  from the short circuit is:

$$\begin{aligned} Z_T &= R_T + jX_T \\ &= \frac{(Z_0 \tan \beta l)^2 \omega C_2 + jZ_0 \tan \beta l [1 - C_1 Z_0 \omega \tan \beta l]}{[1 - C_1 Z_0 \omega \tan \beta l]^2 + [Z_0 \tan \beta l \omega C_2]^2} \end{aligned} \quad \dots\dots (2)$$

The impedance presented to the generator is given by

$$Z_1 = Z_0 \left[ \frac{(R_T + jX_T) \cosh PL + Z_0 \sinh PL}{Z_0 \cosh PL + (R_T + jX_T) \sinh PL} \right] \quad \dots\dots (3)$$

where  $P = \alpha + j\beta$  is the propagation constant of the line and the resulting current drawn from the generator will be

$$i = E/Z_1 \quad \dots\dots (4)$$

At resonance,  $i$  will be in phase with  $E$ , so that the imaginary part of  $Z_1$  will vanish and the value of  $i$  at resonance is given by

$$i = \frac{E}{Z_0} \left[ \frac{(R_T^2 + X_T^2)(\sinh^2 \alpha L + \sin^2 \beta L) + Z_0^2(\cosh^2 \alpha L - \sin^2 \beta L) + Z_0(R_T \sinh 2\alpha L - X_T \sin 2\beta L)}{\frac{1}{2}(R_T^2 + X_T^2 + Z_0^2) \sinh 2\alpha L + R_T Z_0 \cosh 2\alpha L} \right] \quad \dots\dots (5)$$

with the resonance condition that

$$\frac{1}{2}[Z_0^2 - (R_T^2 + X_T^2)] \sin 2\beta L + Z_0 X_T [\cosh^2 \alpha L - \sin^2 \beta L] = 0.$$

In order to simplify equation (5), the  $Q$  factor of the cavity was determined with and without water in the capillary, by the method of plotting the square law response curve against frequency. The values 1500 and 2000 respectively were obtained, with a frequency shift of less than 1 in 3000 Mc/s. No further frequency shift could be detected when normal potassium chloride solution was substituted for distilled water. The large value of the  $Q$  factor even with water or saline present in the tube implied that  $R_T$  was very small compared with  $Z_0$ . The very slight change in tuning was taken to imply that  $X_T$  also was small compared with  $Z_0$ , and that  $\beta L$  was very nearly  $\pi$ .

Using these experimental conclusions, equation (5) may be simplified considerably to

$$i = \frac{E}{Z_0} \left[ \frac{Z_0 \cosh^2 \alpha L}{\frac{1}{2} Z_0^2 \sinh 2\alpha L + R_T Z_0 \cosh 2\alpha L} \right] \quad \dots\dots (6)$$



Substituting for  $R_T$  from the real part of equation (2), and neglecting terms containing  $\tan \beta l$  in the denominator, we obtain

$$i = \frac{E}{Z_0} \left[ \frac{\cosh^2 \alpha L}{\frac{1}{2} Z_0 \sinh 2\alpha L + \cosh 2\alpha L (Z_0 \tan \beta l)^2 \omega C_2} \right] = \frac{1}{A + B\epsilon''} \dots (7)$$

where  $A$  and  $B$  are constants, and equation (1) has been used to substitute for  $C_2$ .

In the cavity,  $i$  is directly proportional to the maximum tangential magnetic field stimulating the detector, and the e.m.f. injected into the detector circuit will be proportional to  $i$ .

The imaginary part of the dielectric constant of saline solution may be considered to be made up of two parts:

$$\epsilon_s'' = (2\sigma_{DS} + 2\sigma_{IS}) \nu \dots (8)$$

where  $\sigma_{DS}$  represents the solution conductivity due to dipolar relaxation and  $\sigma_{IS}$  the high frequency ionic conductivity.  $\nu$  is the frequency of the applied field.

For distilled water the expression becomes

$$\epsilon_W'' = 2\sigma_{DW} \nu \dots (9)$$

Using the suffixes W and S to refer to distilled water and saline solution respectively, it follows from equations (7), (8) and (9) that

$$\frac{i_W - i_S}{i_S} = \frac{B(\epsilon_s'' - \epsilon_W'')}{A + B\epsilon_W''} = K[\sigma_{DS} - \sigma_{DW} + \sigma_{IS}] \dots (10)$$

where  $K = 2B/[A + B\epsilon_W'']\nu$  and can be regarded as a constant when distilled water is used as the standard.

The experimentally measured quantity  $\delta$  is given by  $(i_W^2 - i_S^2)/i_W^2 = \delta$ ; it therefore follows that

$$(i_W - i_S)/i_S = (1 - \delta)^{1/2} - 1 \dots (11)$$

#### § 4. CALIBRATION OF THE APPARATUS

For the purposes of calibration, the response of the apparatus for normal and half normal solutions of potassium, sodium and lithium chlorides was found at temperatures from 18°C to 25°C. Using the results of Collie, Ritson and Hasted (1948) for these concentrations, i.e. that the ionic conductivities may be assumed to be equal to their low-frequency values, it was found that the ratio of  $(i_W - i_S)/i_S$  to the corresponding d.c. conductivity was in each case the same, with a maximum deviation of 2%, for lithium chloride. This confirms equation (10), in which one would expect  $\sigma_{IS}$  to be large compared with the difference between  $\sigma_{DS}$  and  $\sigma_{DW}$ .

In table 1,  $\sigma_{IS}$  and  $\sigma_{DW} - \sigma_{DS}$  are compared for 0.5 normal solutions of potassium and lithium chloride at 25°C, using data from Collie, Ritson and Hasted (1948). The value of  $\epsilon_{DW}''$  at 25°C, has been taken as 11.3.

Table 1

	$\frac{2}{3}\sigma_{IS} \times 10^{-9}$	$\frac{2}{3}(\sigma_{DW} - \sigma_{DS}) \times 10^{-9}$
0.5 n KCl	35.2	0.8
0.5 n LiCl	23.9	0.6

Having thus determined  $K$  in equation (10), the values of  $(i_W - i_S)/i_S$  could be interpreted directly in terms of the ionic conductivity of saline solutions.

## § 5. EXPERIMENTAL RESULTS

The experimental results for potassium chloride solutions are expressed graphically in figure 5, where the ratio of the high-frequency conductivity to the low-frequency value is plotted against concentration in gramme equivalents per litre. The low-frequency conductivity data were obtained from the international critical tables and from conductivity bridge measurements. Sodium and lithium chlorides were also investigated, but these salts did not show such marked effects as potassium chloride. Lithium chloride showed no effect which could be differentiated from the experimental error, but sodium chloride exhibited the same behaviour as potassium chloride at much lower concentrations. The results for sodium chloride are given in table 2.

Table 2

Concentration (g equiv litre)	1	0.5	0.2	0.1	0.0128	0.01	0.0085	0.005
Ratio, 18°C	1	1	1	1	1.29	1.29	1.30	1.35
Ratio, 25°C	1	1	1	1	1.29	1.34	1.36	1.44

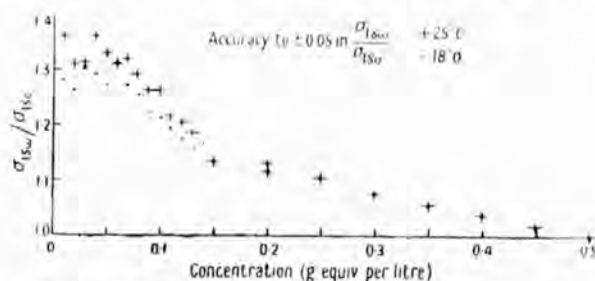

Figure 5. Variation of ratio of high-frequency to low-frequency ionic conductivity with concentration.

The experimental error associated with these results is about  $\pm 0.05$  units on the vertical scale of figure 5 for concentrations below 0.1 normal, but considerably less than this at the higher concentrations. Both sodium and potassium chlorides exhibit a marked increase in conductivity over their low-frequency values in dilute solutions, amounting to about 30%. Such an increase at these concentrations cannot be due to an ion atmosphere relaxation effect of the kind described by Falkenhagen (1934), because the latter effect in 0.01 normal solution would only amount to a 1 or 2% increase. It seems very probable that the result is due to a solvent atmosphere effect, particularly since the conductivity increases as the concentration decreases. A tentative theory based on the interaction between an ion and its solvent atmosphere is discussed in the following section.

## § 6. INTERPRETATION OF RESULTS

The large increase in the high-frequency ionic conductivity of dilute potassium chloride solutions, may be interpreted semi-quantitatively in terms of the interaction of an ion with its surrounding sheath of water molecules. Bernal and Fowler (1933) have pointed out that the intense electrostatic field due to an ion will have a disrupting effect on the structure of the water surrounding it. They postulate that within a certain critical distance from the ion, the water dipoles will be co-ordinated by the ion, while beyond this distance they will be orientated by their mutual dipole attractions. Debye (1929) has calculated that within a sphere

of radius less than  $12 \text{ \AA}$  about a monovalent positive ion, the dielectric constant of water is very much modified. In order to interpret the present results, however, it is necessary to make some assumptions concerning the electrostatic field due to an ion at distances less than  $10 \text{ \AA}$ , and the number of water dipoles in successive layers about the ion which are strongly orientated by it. Pople (1951) has calculated the number of water molecules associated with any one molecule using the experimental results of Morgan and Warren (1938) on the x-ray analysis of water. He finds that a good fit between theory and practice occurs if the first three shells of neighbours surrounding a molecule contain 4, 11 and 22 molecules. A perfect tetrahedral structure would imply 4, 12 and 36 for the numbers in these shells.

We shall assume that in the case of an ion, the radially disposed water molecules surrounding it are packed into shells containing 4, 12 and between 22 and 36 molecules. In addition it is assumed that the inner two shells are packed down closer to each other than they are in the normal water structure, but that the third shell remains at a distance of about  $6 \text{ \AA}$  from the ion which is its position with respect to a central molecule in pure water. The water molecules forming shells one to three are considered to be strongly orientated by the field due to the ion,

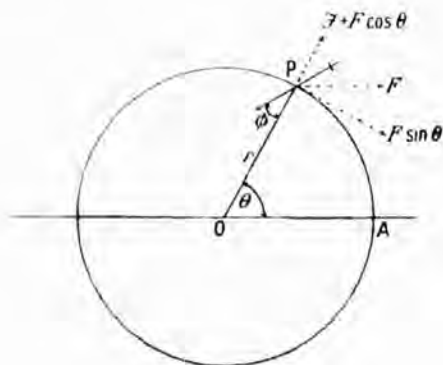

Figure 6.

but beyond shell three the normal tetrahedral structure of water starts to reassert itself. The object of these restrictions is to produce a shell of radially disposed dipoles, which are fairly free from the influence of the dipoles within it.

When calculating the electrostatic field at the third shell due to the central ion, it is not possible to use an expression for the dielectric constant (derived in terms of a continuous medium in a high state of saturation), because the medium within the shell consists simply of one ion and sixteen water molecules. It is assumed therefore that the field due to the central ion is fully effective through the gaps in the screen formed by the dipoles of the inner shells. The majority of the dipoles of shell three then move to positions where this field is a maximum, leaving gaps which can be filled by dipoles from regions beyond shell three. In this way the increase in density due to the presence of ions can also be explained, in spite of the fact that shell three is assumed to remain at a fixed radius from the central ion.

In figure 6, P represents a dipole in the third shell which has been rotated out of the radial direction at the point  $(r, \theta)$  by the application of an external field  $F$ . If a monovalent positive ion is assumed to exist at O, and the applied field is in

the direction OA, it follows that the dipole at P rotates through an angle  $\phi$  given by

$$\tan \phi = \frac{F \sin \theta}{\mathcal{F} + F \cos \theta} \quad \dots\dots (12)$$

where

$$\mathcal{F} = e r^2, \quad \dots\dots (13)$$

$e$  being the electronic charge, and  $\mathcal{F}$  the radial field due to the ion at a distance  $r$  cm.

If  $F \cos \theta \ll \mathcal{F}$ , it follows that

$$\tan \phi = k \sin \theta \quad \text{where} \quad k = F/\mathcal{F} \quad \dots\dots (14)$$

and

$$\cos \phi = (1 + k^2 \sin^2 \theta)^{-1/2}, \quad \sin \phi = k \sin \theta (1 + k^2 \sin^2 \theta)^{-1/2}. \quad \dots\dots (15)$$

The contribution to the field at O along OA by the dipole at P is given by

$$\delta f = \frac{\mu}{r^3} [2 \cos \theta \cos \phi - \sin \theta \sin \phi]$$

where  $\mu$  is the effective dipole moment of the water molecule. Substituting from equation (15), this becomes

$$\delta f = \frac{\mu}{r^3} \left[ \frac{2 \cos \theta - k \sin^2 \theta}{(1 + k^2 \sin^2 \theta)^{1/2}} \right].$$

If a symmetrical distribution of dipoles is considered, in which a number  $n_\theta$  is associated with the angle  $\theta$ , the total contribution of the shell to the field at O along OA is given by

$$f = - \frac{k\mu}{r^3} \sum \frac{n_\theta \sin^2 \theta}{(1 + k^2 \sin^2 \theta)^{1/2}}. \quad \dots\dots (16)$$

If  $n$  dipoles are uniformly distributed, it is permissible to integrate equation (16), which then becomes

$$f = - \frac{2}{3} k\mu n / r^3. \quad \dots\dots (17)$$

The value of  $\mu$  is given by the Langevin expression

$$\mu = \mu_0 \left[ \coth \frac{\mu_0 \mathcal{F}}{kT} - \frac{kT}{\mu_0 \mathcal{F}} \right] \quad \dots\dots (18)$$

where  $\mu_0$  is the true dipole moment of water =  $1.87 \times 10^{-18}$  e.s.u.,  $k$  is Boltzmann's constant =  $1.37 \times 10^{-16}$ ,  $T$  is the absolute temperature =  $298^\circ$ .

Using the value  $4.8 \times 10^{-10}$  e.s.u. for the value of  $e$  in equation (13), and putting  $r = 6 \text{ \AA}$ , equation (17) becomes on substitution of equations (13), (14) and (18)

$$f = -0.035nF. \quad \dots\dots (19)$$

The resultant field acting upon the ion is thus

$$F + f = F[1 - 0.035n]. \quad \dots\dots (20)$$

The fact that a positive ion will move in the direction of the applied field sets the upper limit to  $n$  at the value  $1/0.035$  i.e.  $n_{\text{max}} = 28$  molecules.

It must be noted that this number represents the maximum number of molecules in the third shell which are fully available to contribute a maximum reaction to the field at the ion; it does not necessarily represent the total number of molecules in the shell.

At sufficiently high frequencies, the molecules of the third shell will lag behind the field as they swing about their equilibrium position, and at the same time the

amplitudes of their swings will diminish. Equation (20) may be rewritten in a general form as follows:

$$R_{\omega} = F \left[ 1 - \frac{0.035n}{1 + \omega^2\tau^2} \right] \quad \dots\dots(21)$$

where  $R_{\omega}$  now represents the resultant field parallel to and in phase with the applied field  $F$ ,  $\tau$  is the relaxation time of the molecules of the shell, and  $\omega$  the angular frequency of the applied field. Equation (10) also expresses the variation of conductivity with frequency according to this model. The ratio of the high-frequency conductivity to the low-frequency conductivity is given by

$$\frac{R_{\omega}}{R_0} = \frac{\sigma}{\sigma_{180}} = \frac{1 + \omega^2\tau^2 - 0.035n}{(1 + \omega^2\tau^2)(1 - 0.035n)} \quad \dots\dots(22)$$

A suitable value of  $\tau$  is chosen corresponding to the relaxation wavelength of concentrated solutions of potassium chloride as measured by Collie, Ritson and Hasted (1948), namely 1.4 cm for 2-normal solutions. In the present work,  $\omega$  was  $2\pi \times 3 \times 10^9$  whence  $\omega\tau$  becomes 0.14. The observed ratio for  $\sigma_{180}/\sigma_{180}$  in the present work was 1.3. Substituting these values into equation (22) we have

$$1.3 = \frac{1 + (0.14)^2 - 0.035n}{(1 + (0.14)^2)(1 - 0.035n)}$$

whence  $0.035n = 0.94$  and  $n = 27$  to the nearest whole number, in good agreement with the theory.

It is interesting to consider the predictions of this model at higher frequencies. At frequencies such that  $\omega\tau = 1$ , i.e. at about 21 400 Mc s, the ratio of the high-frequency conductivity to the low-frequency value should be about 5 for dilute solutions of potassium chloride. Some indirect evidence in support of this is contained in a paper by Gärtner (1931), who measured the conductivity of solutions of magnesium sulphate in glycerine to which 4% of water had been added. After allowing for the contribution to the conductivity due to dipolar relaxation in the glycerine, the observed ionic conduction was some five times the low-frequency value in concentrations of 0.1 molar. Bearing in mind the fact that the magnesium ion is divalent, the radius of the equivalent shell is extended to 8.5 Å, which, taken in conjunction with the larger size of the glycerine molecule, could well produce effects similar to the results observed here for aqueous potassium chloride solutions.

Equation (21) may be written in a more generalized form as

$$R_{\omega} = F \left[ 1 - \frac{\psi(\mu_0 e' / a)}{1 + \omega^2\tau^2} \right] \quad \dots\dots(23)$$

where  $\psi(\mu_0 e' / a)$  is some function of the expression in parentheses,  $e'$  being the charge on the ion, and  $a$  the ionic radius. If this equation should represent the field acting upon an ion, the following statements may be made: (i) The low frequency conductivity should decrease as  $e'/a$  increases. (ii) At high frequencies an anomalous dispersion of conductivity should be observed provided  $\omega\tau$  approaches unity. At high concentrations  $\tau$  is likely to diminish due to the proximity of positive and negative ions, and this would cause the dispersion effect to be moved bodily to higher frequencies. The observed decrease in the dispersion effect for potassium chloride as the concentration was increased could be explained in this way. (iii) At very high concentrations, the proximity of ions

of like charge would be a 'shell-breaking' effect leading to an increase in conductivity. This increase, however, would be offset by the dissymmetry and electrophoretic effects described in the Debye-Hückel (1923) theory of electrolytes. In addition, ionic association of the type postulated by Bjerrum (1926) would cause a further decrease in conductivity. The combined action of these effects could lead to the observed linear decrease in the conductivity of concentrated solutions of strong electrolytes at low frequencies. Under these circumstances, the only high-frequency dispersion effect would be that described by Falkenhagen (1934). Note that in the above theory  $\tau$  refers to the relaxation time of a water molecule in the presence of the strong field due to an ion. The effect of the field due to the ion superposed upon the mutual dipole forces would be to shorten the relaxation time of a dipole in a shell, because such dipoles would have a preferred orientation toward the ion. A neighbouring ion of opposite sign would tend to increase the orienting field, and thus reduce the relaxation time even further.

A more exact theory of this effect must be able to account for the large difference in concentration at which the effect is observed in potassium and sodium chloride solutions.

Further work at a frequency of  $3 \times 10^9$  c/s on ions of higher valency is in course of preparation, and will be published later.

#### ACKNOWLEDGMENTS

The authors wish to thank the members of the physics and chemistry departments of Bedford College for their helpful criticisms during the course of this work. In particular our thanks are due to Mr. F. Grimes of the Physics Department for the design and manufacture of a tap controlling the flow of liquids in the apparatus. Mrs. V. Smith was working on behalf of the British Empire Cancer Campaign and thanks them for their continued help during the course of this investigation.

Due acknowledgment is also made to the Chief Superintendent, Radar Research and Development Establishment, for the loan of an N.P.L. type cavity wavemeter.

#### REFERENCES

- BERNAL, J. D., and FOWLER, R. H., 1933, *J. Chem. Phys.*, **1**, 515.  
BJERRUM, N., 1926 a, *K. Danske Vidensk. Selsk. Mat. Fys. Medd.*, **7**, 9; 1926 b, *Ergebn. exakt. Naturw.*, **6**, 125.  
COLLIE, C. H., RITSON, D. M., and HASTED, J. B., 1948, *J. Chem. Phys.*, **16**, 1.  
DEBYE, P., 1929, *Polar Molecules* (New York: Chemical Catalog Co.).  
DEBYE, P., and HÜCKEL, E., 1923, *Phys. Z.*, **24**, 185, 305.  
FALKENHAGEN, H., 1934, *Electrolytes* (Oxford: University Press).  
GÄRTENER, H., 1931, *Phys. Z.*, **32**, 919.  
MORGAN, J., and WARREN, B. E., 1938, *J. Chem. Phys.*, **6**, 666.  
POPLE, J. A., 1951, *Proc. Roy. Soc. A*, **205**, 163.  
SAXTON, J. A., and LANE, J. A., 1952, *Proc. Roy. Soc. A*, **214**, 531.