

A STUDY OF AUTOTOMY IN DECAPOD CRUSTACEA

IAN FINDLAY B.Sc.

SUBMITTED FOR THE DEGREE OF Ph.D.
BEDFORD COLLEGE, (UNIVERSITY OF LONDON),
REGENT'S PARK, LONDON. NW1 4NS.

SEPTEMBER 1977



ProQuest Number: 10098314

All rights reserved

INFORMATION TO ALL USERS

The quality of this reproduction is dependent upon the quality of the copy submitted.

In the unlikely event that the author did not send a complete manuscript and there are missing pages, these will be noted. Also, if material had to be removed, a note will indicate the deletion.

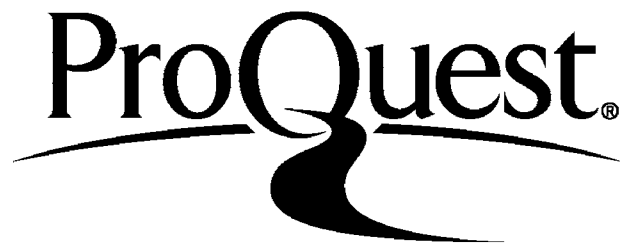

ProQuest 10098314

Published by ProQuest LLC(2016). Copyright of the Dissertation is held by the Author.

All rights reserved.

This work is protected against unauthorized copying under Title 17, United States Code.
Microform Edition © ProQuest LLC.

ProQuest LLC
789 East Eisenhower Parkway
P.O. Box 1346
Ann Arbor, MI 48106-1346

A STUDY OF AUTOTOMY IN DECAPOD CRUSTACEA

IAN FINDLAY

Autotomy is the process whereby an animal can discard a part of its body from a preformed breakage plane. This study examines the natural occurrence of limb autotomy in the crab Carcinus maenas in the Yealm estuary, Devon; and the nervous control of limb autotomy in the hermit crab Pagurus bernhardus and the shore crab Carcinus maenas.

Of the crabs caught in the Yealm estuary in monthly samples between February 1976 and January 1977, 13.2% had lost one or more limbs, with males showing a greater incidence of autotomy (14.5%) than females (12.2%). There is a significant positive relationship between crab's size and incidence of autotomy and seasonal changes in the incidence of autotomy can be explained in terms of alterations of the mean size of crabs caught in each monthly sample.

Limb autotomy in Pagurus and Carcinus results from limb injury and coactivation of the two BI levator muscles. The smaller posterior levator muscle (PL) rotates to direct isometric force from the large anterior levator muscle (AL) onto a plug in the breakage plane which encircles the BI and cause autotomy. During normal locomotion, although the PL muscle is electrically active its tendon does not rotate and AL force is directed away from the plug in the breakage plane.

The nervous control of limb autotomy is a combination of injury induced central command and feedback from a peripheral sense organ. Injury causes high frequency excitation of AL motor neurones and inhibition of PL motor neurones. The PL muscle rotates, as during autotomy, when the sense organ CSD₁ is stimulated by strong isometric contractions of the AL muscle. This investigation shows that PL rotation at autotomy results from such stimulation of CSD₁ and not central nervous command. Accidental autotomy in inappropriate circumstances is prevented when CSD₁ inhibits AL contraction, inhibition which is avoided by injury induced excitation of AL motor neurones to cause autotomy.

CONTENTS

GENERAL INTRODUCTION	9.
SECTION 1 : THE INCIDENCE OF AUTOTOMY IN <u>Carcinus</u> <u>maenas</u> IN THE YEALM ESTUARY, DEVON.	16.
INTRODUCTION	17.
MATERIALS AND METHODS	22.
- Yealm estuary	22.
- Sampling technique	23.
RESULTS	29.
- Analysis of the total number of <u>Carcinus</u> caught in the Yealm estuary. Combined data of thirteen monthly samples between February 1976 and January 1977	29.
- Analysis of the seasonal trends shown by <u>Carcinus</u> in the Yealm estuary	49.
DISCUSSION	74.
SECTION 2 : THE MECHANISM AND NERVOUS CONTROL OF LIMB AUTOTOMY IN THE HERMIT CRAB <u>Pagurus bernhardus</u> (ANOMURA) AND THE SHORE CRAB <u>Carcinus maenas</u> (BRACHYURA)	82.
INTRODUCTION	83.
MATERIALS AND METHODS	90.
- Animals	90.
- Anatomy	90.

- Scanning electron microscopy	91.
- Axonal iontophoresis of cobalt chloride	91.
- Recording techniques	92.
- Autotomy monitor	94.
- Muscle wet weights and limb moments	94.
RESULTS	96.
I. THE ANATOMY OF THE BI MUSCULATURE AND CUTICLE STRUCTURE	96.
- Anatomy of the BI musculature	96.
- Innervation of the BI musculature	105.
- Intracellular staining of BI motor neurons of <u>Pagurus</u> 3LP	108.
- Structure of the BI and effects of levator tendon interactions	120.
II. THE MECHANISM OF AUTOTOMY	130.
- Sensory reflex responses in BI motor neurons	131.
- The posterior levator muscle and innervation	138.
- Responses of the BI levator muscles to injury and autotomy	150.
- Activity in the BI muscles during locomotion	154.
- The mechanics of the BI cuticle during locomotion and autotomy	158.
- The role of the PPL muscle	164.

III. THE NERVOUS CONTROL OF AUTOTOMY AND THE ROLE OF CSD ₁ IN AUTOTOMY AND LOCOMOTION	166.
- The central nervous response to injury	167.
- Reflex responses elicited by AL tension leading to cuticular fracture	171.
- The effect of CSD ₁ stimulation upon AL motor neurones	174.
- The role of CSD ₁ in limb autotomy and locomotion	184.
DISCUSSION	193.
GENERAL DISCUSSION	208.
ACKNOWLEDGEMENTS	223.
APPENDIX 1 : AXONAL IONTOPHORESIS OF COBALT CHLORIDE	224.
- Introduction	225.
- Apparatus	226.
- Technique	226.
- Discussion	230.
BIBLIOGRAPHY	233.

FIGURES

1. The Yealm estuary	21.
2. The size distribution of <u>Carcinus</u> caught in the Yealm estuary between February 1976 and January 1977	28.
3. The incidence of autotomy in different size groups of <u>Carcinus</u>	44.
4. The incidence of autotomy in crabs caught in different parts of the Yealm estuary	48.
5. The numbers of <u>Carcinus</u> caught in the Yealm estuary in each monthly sample	52.
6. The sex ratio of <u>Carcinus</u> in each monthly sample	54.
7. Seasonal changes in the distribution of <u>Carcinus</u> within the Yealm estuary	56.
8. The size distribution of male <u>Carcinus</u> in each monthly sample	63.
9. The size distribution of female <u>Carcinus</u> in each monthly sample	65.
10. Seasonal variation in the incidence of autotomy in <u>Carcinus</u>	69.
11. The relationship between the incidence of autotomy and crab size	71.
12. Drawings of the third left pereopod of <u>Pagurus</u>	98.
13. Drawings of a walking leg and cheliped of <u>Carcinus</u>	102.

14. AL motor neurones of 3LP in Pagurus revealed
by cobalt iontophoresis 110.
15. DEP motor neurones of 3LP in Pagurus revealed
by cobalt iontophoresis 114.
16. CB sensory axons of 3LP in Pagurus revealed
by cobalt iontophoresis 118.
17. Diagrammatic representation of Pagurus BI
showing the effects of tendon interactions 126.
18. Internal structure of the BI and levator
tendons of Carcinus 128.
19. Resistance reflexes in BI motor neurones 133.
20. Responses of CSD₁ and it's reflex loops 135.
21. The PL muscle of Pagurus 141.
22. The RPL muscle of Carcinus 143.
23. The PPL muscle of Carcinus 148.
24. BI muscle responses during autotomy 152.
25. BI muscle responses during locomotion 157.
26. Diagrammatic representation of Pagurus BI
showing probable mechanics during locomotion
and autotomy 161.
27. Relationship between BI muscle weight and
limb inertia in Carcinus 163.
28. The central nervous response to injury in
BI motor units 169.
29. Sensory and motor responses to artificial
autotomy 173.

30. Inhibition of tonic activity in motor units by
CSD₁ stimulation in Pagurus 178.
31. Inhibition of resistance reflex activity by
CSD₁ stimulation in Pagurus 180.
32. Inhibition of resistance reflex activity by
CSD₁ stimulation in Carcinus 182.
33. Role of CSD₁ in limb autotomy in Pagurus. 186.
34. Role of CSD₁ in autotomy and locomotion in
Carcinus 190.
35. Scanning E.M. photographs of Pagurus and
Carcinus BIs 202.

TABLES

1. Raw numbers of <u>Carcinus</u> caught in the Yealm estuary between February 1976 and January 1977	31-34.
2. The incidence of autotomy in <u>Carcinus</u>	35.
3. The incidence of multiple autotomies in <u>Carcinus</u>	36.
4. The incidence of autotomy of particular limbs of <u>Carcinus</u>	39.
5. The incidence of regeneration in <u>Carcinus</u>	41.
6. The numbers of <u>Carcinus</u> caught in each monthly sample	57.
7. Bottom water temperatures from the Yealm estuary	61.
8. The innervation of the PL muscle of <u>Carcinus</u>	146.

GENERAL INTRODUCTION

Autotomy is the term which describes the ability of animals to discard a part of their body. Fredericq (1883) derived the term from the Greek for self-cutting and used it to describe the way that some crustaceans are able to cast off their limbs. The ability to shed a part of the body is not confined to crustaceans although most interest has centered upon this group of animals. Autotomy of limbs and other structures is to be found in widely separate phylogenetic groups and although the phenomenon may have evolved in these groups for similar reasons, there is no phylogenetic link between the development of the reflex in the separate groups. Autotomy appears to have developed independently in groups of animals where the ability to lose a part of the body does not permanently impair the normal activity of the individual, can be made good by regeneration, and presumably increases the chance of survival of the animal.

McVean (1975) recently reviewed the mechanisms and value of autotomy in a wide range of animals and only a cursory examination of autotomy outside the Crustacea will be attempted here. The autotomy of limbs appears to be confined to arthropods; outside the Crustacea autotomy has also been examined in phasmid insects (Possompes, 1961) and spiders (Bauer, 1972). Among the molluscs,

some prosobranchs can shed a part of the foot (Fishelson & Kidron, 1968) and in some bivalves the pallial tentacles can be autotomised (Morton, 1973). The echinoderms are able to throw off a variety of structures when threatened or injured; starfish and brittlestars can autotomise their arms (King, 1898, 1900; Delage & Herouard, 1903; Wilkie, cited in McVean, 1975), and one of the more unusual acts of autotomy occurs in sea-cucumbers where, when disturbed, they will evert and throw out their guts (Swann, 1966; Smith & Greenberg, 1973). Autotomy is not confined to the invertebrates, although in vertebrates only tails may be lost. Pieces of the tails of salamanders (Wake & Dresner, 1967) and lizards (Pratt, 1946; Sheppard & Bellairs, 1972) can be autotomised, while the complete tails of mice can be lost (Layne, 1972).

The ability to autotomise a part of the body is usually associated with anatomical and mechanical specialisations which involve the provision of a plane of weakness so that autotomy usually occurs at the same place and does not just consist of tearing of tissue. There may also be muscles which act upon this plane of weakness to facilitate the act of severance. The essence of autotomy, the ease with which an animal may part with a portion of its body, is what has attracted most interest to the phenomenon.

The specialisation of parts of the crustacean limb to achieve autotomy will be discussed in detail in later

sections of this thesis, suffice it to say at this stage that there is a preformed breakage plane which encircles the limb and autotomy is caused when muscles are stimulated to act upon it. A preformed breakage plane, which allows for the clean separation of the peripheral limb from a retained stump is also found in stick insects (McVean, 1975), and muscle action upon inelastic pieces of cuticle also cause limb autotomy in the stick insects (Possompes, 1961) and spiders (Bauer, 1972). A well defined septum, along which separation occurs, is also found in prosobranch molluscs which autotomise their foot (Fishelson & Kidron, 1968); the septum runs from the dorsal to ventral margins of the foot and the only tissue not influenced by the plane are the pedal nerves which are torn at autotomy. A series of autotomy septa are found running across the tails of salamanders (Wake & Dresner, 1967) and lizards (Pratt, 1946; ^hSheppard & Bellairs, 1972). These septa lie between segmental muscle blocks and fat bodies; in both groups the spinal cord shows marked constrictions at the planes of separation (Pratt, 1946; Wake & Dresner, 1967; Sheppard & Bellairs, 1972). In salamanders the break occurs between the vertebrae (Wake & Dresner, 1967); in lizards, through the vertebrae where a well defined fracture plane can be observed (Pratt, 1946; Sheppard & Bellairs, 1972).

In other groups the breakage plane is less well defined, but autotomy still tends to occur at the same

place within a species or group (McVean, 1975). The pallial tentacles of some bivalve molluscs constrict part of the way along their length (Fishelson & Kidron, 1968) and sea-cucumber gut muscles usually break at the same place although a distinct fracture plane cannot be observed (Smith & Greenberg, 1973).

The degree to which the animal itself causes separation along such fracture planes and the extent played by outside agents varies from group to group and in some cases from species to species. Where there is a well defined autotomy plane it is frequently the action of muscles associated with the plane which cause separation. The effects of muscle action on the breakage plane in crustacean limbs will be fully described later. The muscles which cause separation of the fracture plane may, however, also be used in other roles associated with the normal function of the autotomised structure and therefore the normal function and autotomy have to be kept apart. This ^{separation may be due to singular} ~~may take the form of specialised~~ neuronal control of the muscles involved, either ^{particularly} ~~specialised~~ causing autotomy or avoiding it's occurrence in inappropriate circumstances. A common feature noted by many investigators may also provide part of the explanation. To lose these structures, the structures often have to be held or fixed so that the muscles have a resistance to work against and thus direct their actions towards the breakage plane. In normal activity the muscles' action would be spread and the

mechanical integrity of the breakage planes retained. A resistance to movement is required ^{for} ~~to~~ autotomy of crustaceans limbs (Fredericq, 1883, 1892), for the separation of the tails of salamanders and lizards (Pratt, 1946; Wake & Dresner, 1967; Sheppard & Bellairs, 1972) and if the foot of Gena (Prosobranchia : Mollusca) is not held, it has to be forced against a hard surface (Fishelson & Kidron, 1968). Less obvious examples are found, for instance when Galeomma (Bivalvia : Mollusca) autotomises it's pallial tentacles the coelomic pressure is increased and a circular ring of muscles contract around an ill-defined septum (Morton, 1973). Increased coelomic pressure combined with strong contractions of certain pyloric muscles also result in gut eversion and autotomy in sea-cucumbers (Smith & Greenberg, 1973).

This study examines certain aspects of autotomy in two species of decapod crustaceans, the hermit crab Pagurus bernhardus (L.) (Anomura) and the shore crab Carcinus maenas (Brachyura). In recent years the mechanism and nervous control of limb autotomy in crustaceans has attracted considerable interest, interest that has involved the application of electrophysiological techniques to the problem itself (McVean, 1970, 1973, 1974; Moffett, 1973, 1975) and to related subjects, including the role of the muscles involved in autotomy during their normal function, levating the limb (Clarac & Wales, 1970; Clarac

& Coulmance, 1971; Moffett, 1975), and the role of the sense organ cuticular stress detector one (CSD₁) in autotomy and locomotion (Clarac & Wales, 1970; Clarac et al., 1971; McVean, 1975; Moffett, 1975; Clarac, 1976). These studies have led to two opposing hypotheses concerning the mechanism and nervous control of autotomy. One was put forward by McVean (1973, 1974, 1975), the other suggested by Moffett (1973, 1975) and supported by Clarac (1976). A re-examination of these hypotheses, the anatomy and muscle activity involved in causing limb autotomy, and an investigation into its nervous control including the role of the CSD₁ sense organ, were undertaken and are described in section two of this thesis.

Section one describes an investigation into the naturally occurring incidence of limb autotomy in the crab Carcinus in the estuary of the river Yealm on the south coast of Devon five miles to the east of Plymouth. Three previous studies have been made to determine the natural incidence of autotomy in crustaceans. Paul (1915) looked at Carcinus collected from two rocky shores, Needham (1953) examined autotomy in a wide variety of crustacean species, and McVean (1976) collected Carcinus from three sites in the north-east of England. Each related the incidence of autotomy to the environment of the crabs, their age and sex. All three based their investigations on samples of animals taken from the population either only once, or within a relatively short

time. The investigation described in section one involved sampling from a population of Carcinus at regular intervals for the period of a year, so that changes in the population during this time can be examined and the incidence of limb autotomy can be related to them.

SECTION 1 : THE INCIDENCE OF AUTOTOMY IN Carcinus
maenas IN THE YEALM ESTUARY, DEVON.

INTRODUCTION

The shore crab, Carcinus maenas (L.) can autotomise any one of its ten limbs. A limb is shed by separation around a preformed breakage plane when any part except the dactyl is damaged. An autotomised limb is replaced by regeneration, basal growth of the regenerate occurring within the inter-moult period (Bliss, 1961) and at least one moult is required for the final development of a new, fully functional limb. The loss of a limb thus normally only temporarily affects the crab temporarily.

The effects of limb loss will depend upon the stage in the inter-moult cycle in which the limb is lost (Kuris & Mager, 1975), which limb is lost and the number of limbs lost. The loss of chelipeds would affect the ability of a crab to defend itself and may also affect feeding. The loss of more than one walking limb could influence the mobility of the animal.

It has been suggested that a resistance^a to autotomy increases with age, and also with successive limb loss (Carlisle, 1957, Easton, 1972). Increasing age reduces the frequency of moulting and therefore reduces the opportunities for the crab to replace lost limbs. The individual must balance its subsequent vulnerability against the immediate danger threatened. The evidence for the development of inhibition of autotomy after the loss of several limbs has been based upon rapidly

repeated attempts to cause autotomy in the laboratory (Hoadley, 1934, 1937; Gomez, 1964; Easton, 1972), circumstances which are unlikely to arise in natural situations, also, if a period of time elapses between such repeated stimuli, the resistance to autotomy is not observed (Gomez, 1964; Easton, 1972).

Two previous studies have been made into the natural occurrence of autotomy in Carcinus, first by Paul (1915) and then the more extensive study by McVean (1976). Both examined autotomy in littoral populations, McVean (1976) also examined a sub-littoral population, and they both found that the incidence of autotomy varied with the size of the crabs caught, and McVean (1976) also found differences in the incidence of autotomy which he explained in terms of environmental and behavioural differences between the three populations which he studied.

This study investigates the occurrence of autotomy in a brackish water population of Carcinus maenas in the Yealm estuary in south Devon. Crabs were taken from a number of stations extending from the mouth of the estuary, to the upper limits of tidal influence on the river, an area which covers a range of substrate types and tidal influences on exposure, salinity and temperature. This estuary was chosen because it is of convenient size, allowing stations situated along its length to be visited within a relatively short period. Sampling from the estuary was continued at approximately monthly intervals.

over a period of a year. Therefore not only could the incidence of autotomy be estimated and related to the size and sex of the crabs, and their position in the estuary, but it was also possible to examine seasonal changes in the crab population and their influence upon the incidence of autotomy.

Fig. 1 : The Yealm estuary, near Plymouth, Devon, showing local features and the sites of eight sampling stations from the mouth of the estuary to the upper limits of tidal influence. The speckled areas mark mud flats exposed at low water.

Reproduced from the Ordnance Survey Map (25,000 : 1 scale) with the sanction of the Controller of Her Majesty's Stationary Office, Crown Copyright reserved.

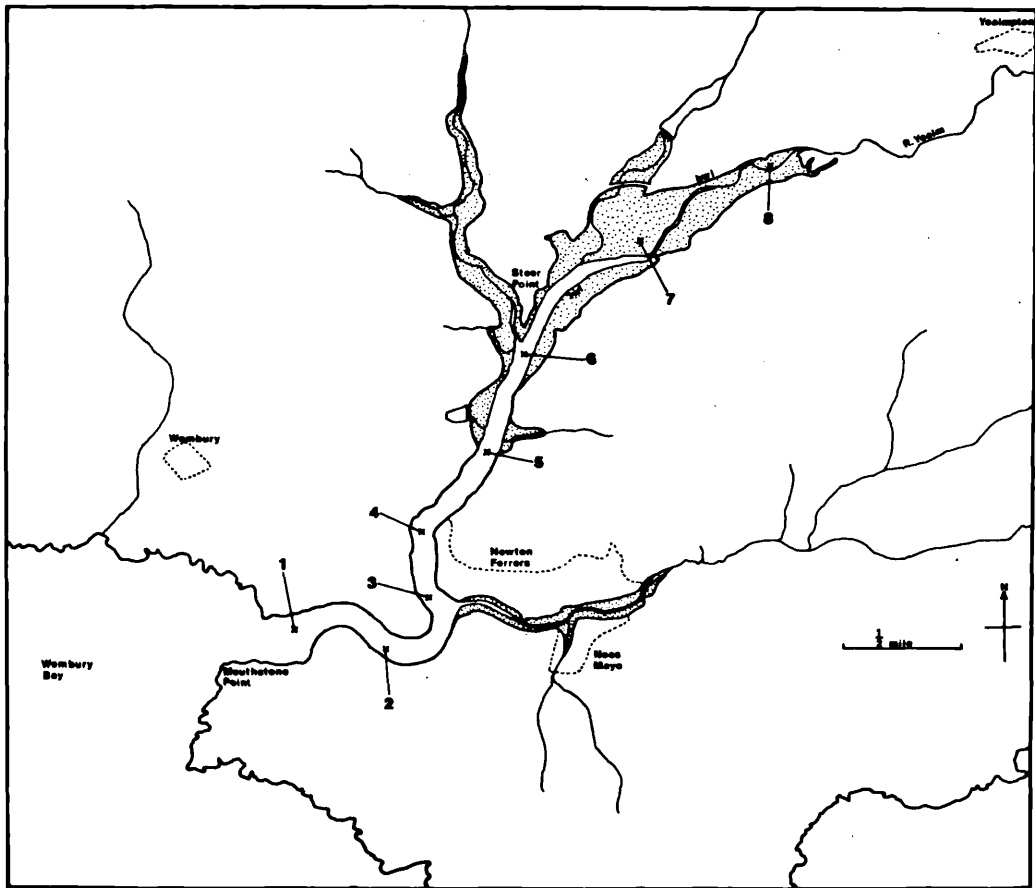

MATERIALS AND METHODS

Yealm estuary

The estuary of the river Yealm is situated 4-5 miles east of Plymouth on the south Devon coast. The river runs through the town of Yealmton and becomes a true estuary approximately a mile to the west of the town. The estuary, known locally as the "Fjord of the West" runs first south-west and then south before emerging into the West Channel in Wembury Bay (Fig. 1).

The estuary is also fed by several other streams, the largest of which runs through the village of Newton Ferrers. This study was confined to the main stream of the Yealm river.

The mouth of the estuary is protected by a sub-littoral sand bar which is only uncovered at extreme Spring low tide. The effects of the prevailing SW winds which pass directly into the mouth of the estuary are subdued by this sand bar so that rough water does not penetrate far up the estuary.

Sampling stations were situated at regular intervals along the estuary (Fig. 1). Stations 1-6 were situated sub-littorally in reaches retaining water at low tide (Fig. 1). Stations 7 and 8, strictly speaking were littoral, situated above Steer Point, where the estuary drains at low water, leaving only a narrow channel (Fig. 1).

Station 8 was situated at the upper limit of the estuary, a few yards downstream from the point where the river Yealm abruptly expands to form the estuary (Fig. 1). Above this point the effects of tidal water changes are rapidly lost, the narrow river maintaining the same level irrespective of tidal level. Each station could be repeatably sampled since their positions had been fixed with respect to local landmarks.

The substrate of the estuary varies. At the mouth, inside the sand bar, the bottom is made up of boulders on gravel, gradually changing upstream to mud intermingling with the gravel, until, above Steer Point, where the estuary drains at low water, the substrate consists of extensive mud flats (Fig. 1).

Sampling technique

Crabs were trapped in a baited net. The net consisted of a steel circle as a base (approximately 1 m diameter) with two semi-circular steel rings attached at their ends to the base so that when a central line was pulled, the two side rings rose and enclosed the area above the base. This steel framework was lined with nylon netting, and crabs as small as 15 mm carapace width were regularly caught.

Although the use of baited traps for estimating population parameters has been criticized (Walne, 1976), the technique was utilised in this study because of the

ease with which it can be used. Therefore, no absolute analysis of population parameters of the crab Carcinus will be attempted, but the numbers of crabs caught and their relevant characteristics (size, limbs lost, sex ratio etc) will be accepted as representative of the population as a whole.

Initial sampling consisted of leaving the net on the bottom for twenty minutes (two 10 minute periods) at each station. Trapping for set periods of time, however, led to very few crabs being caught at some stations. Since this investigation depends upon a relatively large number of crabs being captured so that a reliable estimate of the number of missing limbs can be obtained, the regime was altered as described below. The adopted system involved capturing a minimum number of individuals and noting the time taken to do so. A minimum number of 30 individuals per station was chosen and trapping continued in ten minute periods until at least this number of crabs per station were caught, up to a maximum period of one hour's trapping (6 x 10 minute periods). If the minimum number of crabs were caught before the maximum time period, this number was adjusted to the number of crabs which would have been caught in one hour's trapping and thus each station within a month's sampling in the estuary and between months could be compared.

All trapping took place, whatever the station, at or within two hours of high water, stations 7 and 8 could

only be sampled at these times and sampling at the other stations was limited to roughly similar tidal conditions. This meant that all of the stations could not be sampled in the same day. Usually two days were required, one for the lower four stations, one for the upper four.

Sampling was carried out at approximately four weekly intervals. The actual dates are given below, with the monthly label which will be used for the rest of this study.

<u>Sampling date</u>	<u>Label</u>
7 & 8 February 1976	F
10 & 11 March	M
7 & 8 April	A
6 & 7 May	M
7 & 8 June	J
5 & 6 July	J
3 & 4 August	A
1 & 2 September	S
30 September & 1 October	O
1 & 2 November	N
30 November & 1 December	DE
30 & 31 December	DL
27 & 28 January 1977	J

Stations were visited in a small rubber dinghy. The net was lowered over the side and the dinghy was anchored

for the duration of the trapping period. Each crab was sexed, the carapace measured to the nearest millimeter across its greatest width, and the occurrence of autotomised and regenerating limbs recorded. All captured crabs were retained in the dinghy until trapping at that station was completed, they were then released into the water.

Fig. 2 : The size distribution of Carcinus maenas caught in the Yealm estuary in thirteen monthly samples between February 1976 and January 1977. The number of crabs in each size group is expressed as a percentage of the total number of crabs caught (3338, Table 1a).

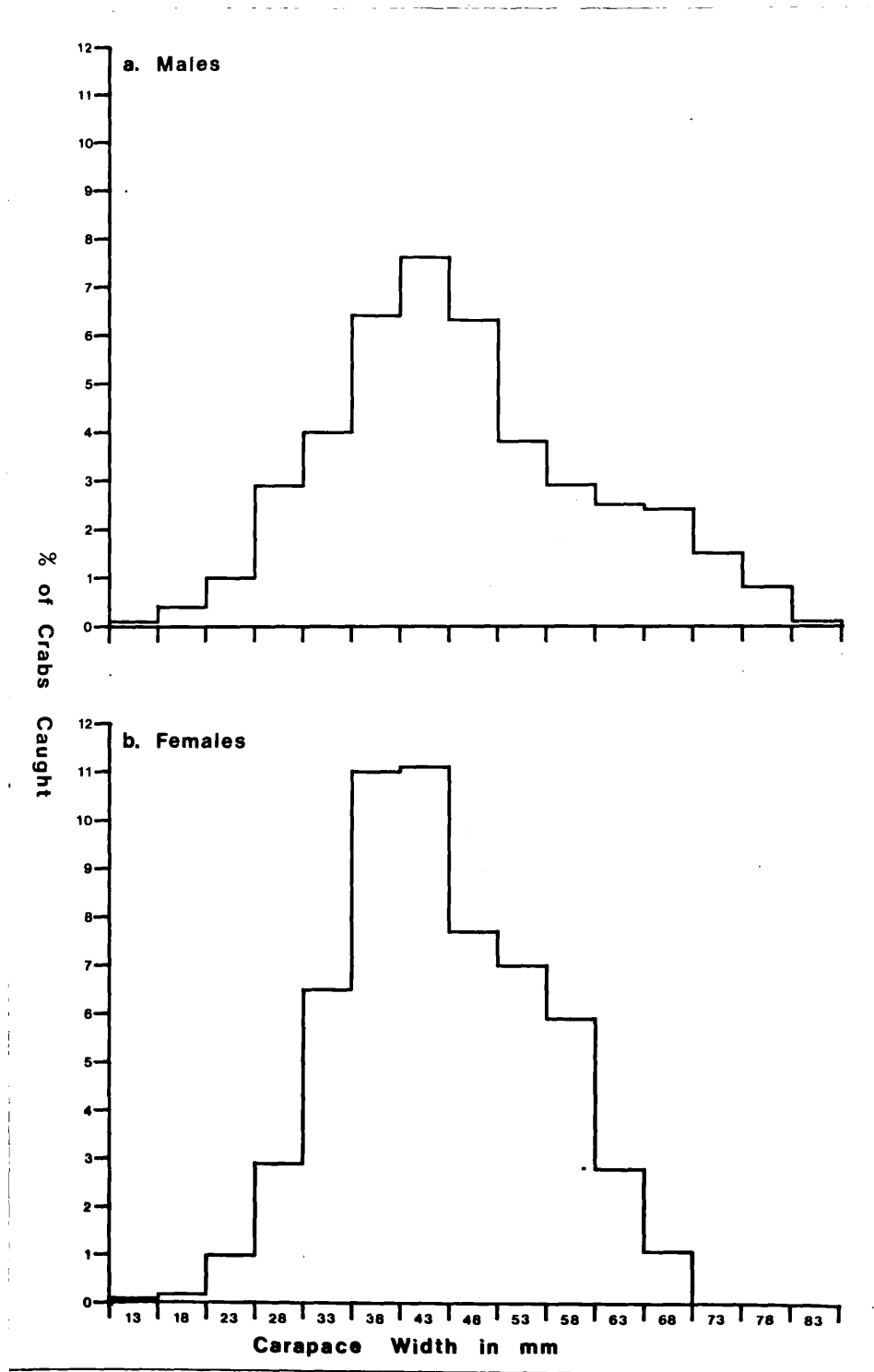

RESULTS

Analysis of the total number of Carcinus caught in the Yealm estuary. Combined data of thirteen monthly samples between February 1976 and January 1977

3338 Carcinus were caught in the Yealm estuary between February 1976 and January 1977 and Table 1 gives the size distribution of the crabs and details of autotomised and regenerating limbs.

Fig. 2 shows the size frequency distribution for male and female Carcinus. For both males (Fig. 2a) and females (Fig. 2b) the frequency distribution of crab sizes is significantly different from a normal distribution (Chi-squared test). Males (Table 1b, Fig. 2a) are on average, slightly larger than females (Table 1c, Fig. 2b), with mean (\bar{x}) sizes of 46.4 mm and 44.6 mm carapace width respectively. The frequency distribution of the two sexes differ. The lower limit for capture by the baited net used here, appears from the data to be 11 mm (Table 1) although reliable capture probably starts at approximately 16 mm carapace width. Crabs of both sexes are caught at this ^olwer end of the size distribution (Table 1b,c, Fig. 2a,b). It is in the larger sizes that the frequency of crabs caught differ. Males are relatively commonly found with carapace widths up to 80 mm, and occasionally above

(Table 1b; Fig. 2a), but female crabs show an abrupt cut off above 70 mm carapace width, no individuals being caught above this limit (Table 1c; Fig. 2b). The narrower size range of female Carcinus is reflected in the smaller standard deviation of their frequency distribution of 10.3, compared with the greater size range and thus standard deviation (13.5) of the males. The allocation of year classes derived from this data will not be attempted.

The incidence of autotomy of one limb and also cumulative limb losses are shown in Tables 2 and 3. Approximately 10% of the population have autotomised one limb, while considerably fewer crabs have lost more than one limb (Table 2). When the data is examined in terms of a binomial distribution, however, a separate trend is revealed. Although there are very few multiple autotomies, analysis of expectation based upon a binomial distribution shows that the observed numbers of multiple autotomies is considerably greater than would be expected when the autotomy of one limb had no influence upon the chances of subsequent autotomies (Table 3). A "tail" in the data indicates that multiple autotomies occur more frequently than could be expected if each autotomy was an independent event; the loss of one limb in some way increases the chances of the loss of other limbs. The build up of a resistance to autotomy after the loss of several limbs shown by some investigators (Hoadley, 1934, 1937; Gomez,

Table 1 : Raw data for Carcinus maenas caught in the Yealm estuary. Data combined from thirteen separate monthly samples from February 1976 to January 1977. Crabs are grouped into 5 mm size intervals, the sizes shown here represent the midpoint of each interval.

Table 1a : Total number of Carcinus maenas caught, both sexes.

Carapace width mm	13	18	23	28	33	38	43	48	53	58	63	68	73	78	83	Total
No. intact crabs	3	20	57	173	298	516	541	390	280	219	121	75	30	14	1	2738
No. crabs missing 1 limb	1	2	3	11	35	41	43	46	42	41	35	27	13	7		347
2 limbs			2	5	5	7	10	6	9	8	7	8	4	3		74
3 limbs					1		3	1	2	5	5					17
4 limbs						1										1
5+ limbs										1						1
No. chelipeds missing	1			4	20	15	24	28	27	23	18	20	4	7		191
No. 1st walking limbs			2	5	3	11	14	12	13	8	12	1	5	3		89
2nd		1	1	5	8	15	13	9	9	14	13	6	4	1		99
3rd			2	3	7	6	11	5	9	20	11	7	3			84
4th		1	2	5	6	9	14	7	8	12	10	11	5	2		92
No. regen. chelipeds		1	1	3	8	11	12	18	19	14	6	4	4	1		102
No. regen. 1st w/limbs					2	4	6	8	4	3	5	1	1			34
2nd				1	3	4	6	4	4		4	2		1		29
3rd			1		2	2	2	4	5	2	2					20
4th				1	4	4	7	6	5	4	4	2	1			38
Total no. of crabs	4	22	64	194	350	582	626	469	361	292	180	116	51	26	1	3338

Table 1b : Males.

Carapace width mm	13	18	23	28	33	38	43	48	53	58	63	68	73	78	83	Total
No. intact crabs	1	14	30	85	111	187	209	169	99	76	59	52	30	14	1	1137
No. crabs missing 1 limb			1	5	15	10	20	25	14	11	18	16	13	7		155
2 limbs				4	3	5	6	3	3	3	2	7	4	3		43
3 limbs					1		2	1	3			1				8
4 limbs																1
5+ limbs							1									0
No. chelipeds missing				2	14	4	13	17	7	6	6	15	4	7		95
No. 1st walking limbs			1	3	1	6	7	7	8	3	4	1	5	2		48
2nd				4	1	8	8	7	5	4	5	6	4	1		53
3rd				2	3	1	6	2	3	3	3	5	3			31
4th				2	5	2	8	3	3	1	4	6	5	2		41
No. regen. chelipeds				2	3	6	7	11	8	5	3	4	4	1		55
No. regen. 1st w/limbs						2	4	3	1	1	2	1				14
2nd				1	1	1	5	1	1		2	1				13
3rd						1	1	4	1		1					9
4th					1	4	4	4	1	1	1	1	1			18
Total no. of crabs	1	14	32	97	134	213	254	212	126	96	85	79	51	26	1	1421

Table 1c : Females.

Carapace width mm	13	18	23	28	33	38	43	48	53	58	63	68	73	78	83	Total
No. intact crabs	2	6	27	88	187	329	332	221	181	143	62	23				1601
No. crabs missing 1 limb	1	2	2	6	20	31	23	21	28	30	17	11				192
2 limbs			2	1	2	2	4	3	6	5	5	1				31
3 limbs							1			5	5					11
4 limbs																0
5+ limbs									1							1
No. chelipeds missing	1			2	6	9	11	11	20	17	12	5				94
No. 1st walking limbs			1	2	2	5	7	5	5	5	8					40
2nd		1	1	1	7	7	5	2	4	10	8					46
3rd			2	1	4	5	5	3	6	17	8	2				53
4th		1	2	3	1	7	6	4	5	11	6	5				51
No. regen. chelipeds			1	1	5	5	5	7	11	9	3					47
No. regen. 1st w/limbs					2	2	2	5	3	2	3					19
2nd					2	3	1	3	3		2	1				15
3rd					2	1	1		4	2	1					11
4th				1	3		3	2	4	3	3	1				20
Total no. of crabs	3	8	32	97	216	369	372	257	235	196	95	37				1917

Table 2 : The incidence of autotomy in Carcinus captured in the Yealm estuary. The percentage of individuals lacking limbs. Combined data of thirteen monthly samples from February 1976 to January 1977.

	Total	Males	Females
Intact	81.9	79.8	83.5
- 1 limb	10.4	10.9	10.0
- 2 limbs	2.2	3.0	1.6
- 3 limbs	0.5	0.6	0.6
- 4 limbs	-	*	-
- 5 limbs	-	-	*
- 4+ limbs	13.2	14.5	12.2

* one male crab was captured missing 4 limbs, and one female crab was captured missing 5 limbs. No crabs were captured missing more than five limbs.

Table 3 : The number of male and female crabs falling into each category of cumulative autotomies compared with the number expected from a binomial distribution.

Number of limbs missing	Observed number of crabs	Expected number of crabs
Males		
0	1137	1110
1	155	210
2	43	18
3	8	1
4	1	0
Females		
0	1601	1566
1	192	251
2	31	18
3	11	1
4	0	0
5	1	0

There is a significant difference (Chi-squared test, $P < 0.001$) between the observed and expected numbers for both sexes.

1964, Easton, 1972) results from the very rapid repetition of attempts to cause autotomy. The evidence presented in Table 3 indicates that in natural circumstances the reverse may instead be true.

The influence of the loss of walking limbs would probably not be felt by the crab until several had been lost, enough to disrupt the mobility of the animal. However, the loss of a cheliped could influence the ability of a crab to defend itself, leaving it more vulnerable to attack and thus to the loss of yet another limb. Examination of the raw data reveals that of crabs which have lost two or more limbs, 52.7% have lost a cheliped as one of these, while only 47.3% have lost only walking limbs in multiple autotomies. Probability states that of two events (loss of a cheliped and one other limb) out of a possible ten events taken two at a time, 37.8% of multiple autotomies should include the loss of a cheliped, while 62.2% should consist of the loss of only walking limbs. Far more chelipeds are lost in multiple autotomies (52.7%) than can be accounted for on the basis of chance (37.8%), this difference is statistically significant ($P < 0.01$) and therefore it is suggested that multiple autotomies, which are more frequent than expected (Table 3), often result because the loss of a cheliped affects the animal so that it is more likely to be placed in situations where it will lose subsequent limbs, than if it had first lost a walking

limb.

When one examines the data, it is obvious that chelipeds are autotomised much more frequently than walking limbs (Table 4). When threatened, individual Carcinus tend to face the threatening object and raise both chelipeds into the threat posture in which both chelipeds are extended laterally, preparatory to striking at the threatening object. This behaviour may, therefore, lead to the chelipeds being damaged by predators or other crabs (Table 4a). In the land crab Gecarcinus this behaviour has been extended to form "attack autotomy" (Robinson et al., 1970). Although female Carcinus are less aggressive than males, their chelipeds are still the most frequently lost limbs (Table 4a,c). As in the males, they commonly respond to a threatening approach by raising the chelipeds in the pre-strike posture.

No one walking leg (or pair of walking legs) are shed in preference to others (Table 4a), any differences between particular walking limbs being slight. There is a slight trend for males to preferentially lose the first two pairs of walking legs, and the females the last two (Table 4a). When the data is divided, however, into the loss of individual limbs and not pairs of pereopods (Table 4b,c) these small trends are lost and there appears to be no real preference for the loss of any particular walking limb.

Table 4 : The incidence of autotomy of particular limb expressed as a percentage of the total number of limbs lost. Combined data of thirteen monthly samples from February 1976 to January 1977.

a.	Total	Males	Females
Chelae	34.5	35.3	33.8
1 st walking	15.6	17.7	13.8
2 nd walking	18.2	19.9	16.5
3 rd walking	15.1	11.6	18.3
4 th walking	16.6	15.5	17.6

b. Males	Left	Right
Chelae	18.4	16.9
1 st walking	10.5	7.2
2 nd walking	10.5	9.4
3 rd walking	4.1	7.5
4 th walking	6.9	8.6

c. Females	Left	Right
Chelae	15.2	18.6
1 st walking	7.6	6.2
2 nd walking	7.9	8.6
3 rd walking	9.0	9.3
4 th walking	9.7	7.9

Crabs were caught which had damaged but un-autotomised limbs, presumably the extent of damage had been insufficient to affect the nerve trunks within the limb (Easton, 1972).

During this investigation the occurrence of regenerating limbs was also noted (Tables 1,5). These were found in two main forms; limb buds which develop fairly rapidly following autotomy, and formed but "immature" limbs which require a moult before attaining full size (Bliss, 1961; Weis, 1976). These two forms are treated together in Table 5.

The incidence of regenerating limbs (223) was much less than autotomised limbs (556; Table 1a). As for autotomised limbs (Table 4), the most commonly observed regenerating limbs were chelipeds (Table 5). Walking limb regenerates were much less frequent (Table 5). No real trend can be observed in the walking legs for the preferred regeneration of a particular limb, which is to be expected since there is no preferred loss of such limbs (Table 4). The number of regenerating 3rd walking limbs is less than observed for other limbs (Table 5) and although it could be said that slightly fewer 3rd walking legs are lost than other limbs (Table 4) the difference is small, and much smaller than the difference between the regenerating 3rd walking limbs and the others. No evidence has been put forward (Bliss, 1961; Weis, 1976) to show that there is a preferred rate of regeneration for particular limbs.

Table 5 : The incidence of regeneration in Carcinus in the Yealm estuary. The incidence of regeneration of particular limbs is expressed as a percentage of the total number of regenerating limbs observed. Combined data of monthly samples between February 1976 and January 1977.

	Total	Males	Females
Chelae	45.7	49.5	42.1
1 st walking	15.2	12.9	17.5
2 nd walking	13.0	12.8	13.2
3 rd walking	9.1	8.3	9.7
4 th walking	17.0	16.5	17.5

It has been suggested that resistance to autotomy increases with the age of the animal (Carlisle, 1957). The data collected here was therefore analysed to examine the relationship between the incidence of autotomised limbs and the size of the animals.

The correlation between the incidence of autotomy and the size of the animals was calculated by comparing the number of intact animals with the number of crabs which had lost one or more limbs in each size group using Kendall's Tau rank correlation test, corrected for ties. Because of the large number of crabs involved in these tests the values for tau are small, but in each case are highly significant.

Total number of crabs (both sexes), tau = +0.134,
P / 0.001

Males, tau = +0.152, P / 0.001

Females, tau = + 0.122, P / 0.001

The increasing incidence of autotomy with increased size is clearly shown in Fig. 3. These histograms only give details for crabs with a carapace width greater than 21 mm (Fig. 3a,b). No male crabs lacking limbs with carapace widths less than 21mm were captured (Table 1b) and although smaller female crabs were caught (Table 1c), they show a high proportion of individuals lacking limbs (33% for the 11-15 mm group, and 25% for the 16-20 mm group, Table 1c) and these figures were omitted from

Fig. 3 : The incidence of autotomy in different size groups of Carcinus maenas, estimated from the total number of crabs caught between February 1976 and January 1977. The incidence of autotomy is calculated as the percentage of crabs within each size group which have lost one or more limbs, compared with the total number of crabs in that size group.

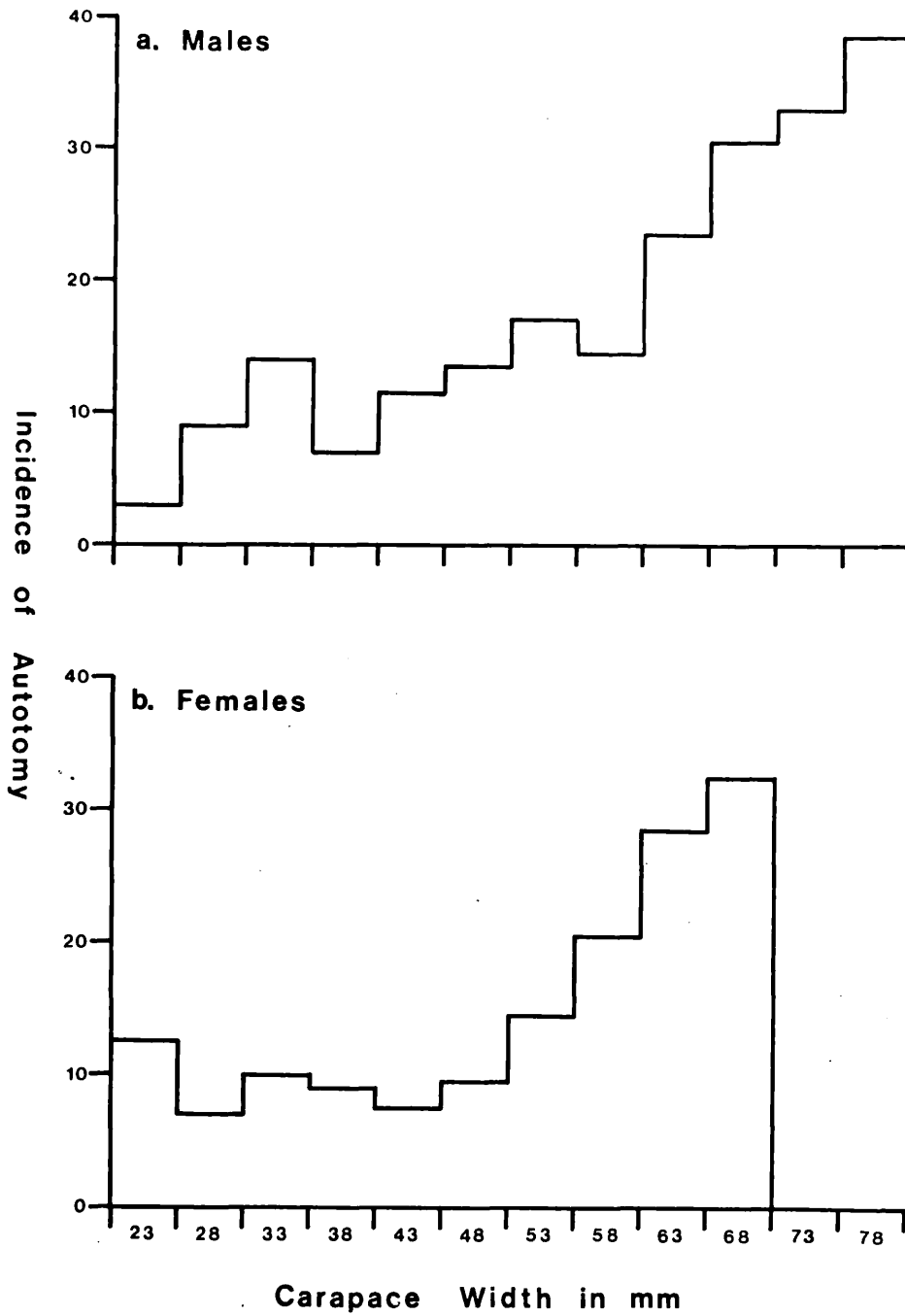

the histogram (Fig. 3b) as they are based upon very few individuals, although the statistical analysis included the full size range of the crabs caught. There is a significant difference ($P < 0.02$) between the male and female correlations shown above, with the males showing a stronger correlation between size and incidence of autotomy than the female crabs.

It was outlined earlier, that the substrate in the Yealm estuary alters in character passing upstream from the mouth. From boulders and shingle, which gradually reduce in size and intermingle with mud, until eventually it is largely made up of expanses of mud (Fig. 1). Fig. 4a shows the incidence of autotomy at each sampling station for all the crabs caught at each station throughout the year from February 1976 to January 1977. As the substrate becomes "softer" the incidence of autotomy declines, except for the top two stations (7 & 8) which drain at low water (Fig. 1).

One explanation for the reduction of the incidence of autotomy with the gradient up the estuary, could be that autotomy results to a significant extent within the population from damage caused to a crab by its environment; ^{where} the movements of large stones and boulders ^{would be} ~~being~~ more likely to damage the crab than soft mud and sand. On stations 7 and 8, however, where the substrate is entirely mud, the incidence of autotomy rises again

(Fig. 4a). Analysing the incidence of autotomy with station from the mouth of the Yealm estuary by Kendall's tau resulted in a significant correlation ($P \leq 0.02$).

This explanation assumes that movement of crabs within the estuary is negligible, and that those crabs caught at any particular station are always to be found in the vicinity of that station. Crabs, instead, are known to migrate onto and off shore with the tide (Edwards, 1958), and individual Cancer have been shown to migrate considerable distances in the North Sea.

Although the substrate cannot entirely be ruled out as a causative agent for autotomy (Paul, 1915, McVean, 1976), another partial explanation could be found by comparing the sizes of individuals caught at each station and the incidence of autotomy at each station. Fig. 4b shows the mean (\bar{x}) size of crabs of both sexes caught at each station for the whole years sampling. It has already been shown that there is a highly significant correlation between the size of crabs and the incidence of autotomy (Fig. 3) and comparing the mean (\bar{x}) size of crabs caught at each station with the incidence of autotomy at that station using Kendall's tau test, results in a significant correlation ($P \leq 0.001$). This result is, however, not to be regarded in absolute terms, but rather as reflecting a trend in the distribution of crabs of different sizes in the estuary. Large crabs are still caught at the higher stations as are small ones

Fig. 4 : The incidence of autotomy in crabs caught at sampling stations in different parts of the Yealm estuary.

a. The incidence of autotomy calculated as the percentage of crabs caught at each station for the whole year's sampling which have lost one or more limbs.

b. The mean size (\bar{x}) of crabs caught at each station for the whole year's sampling.

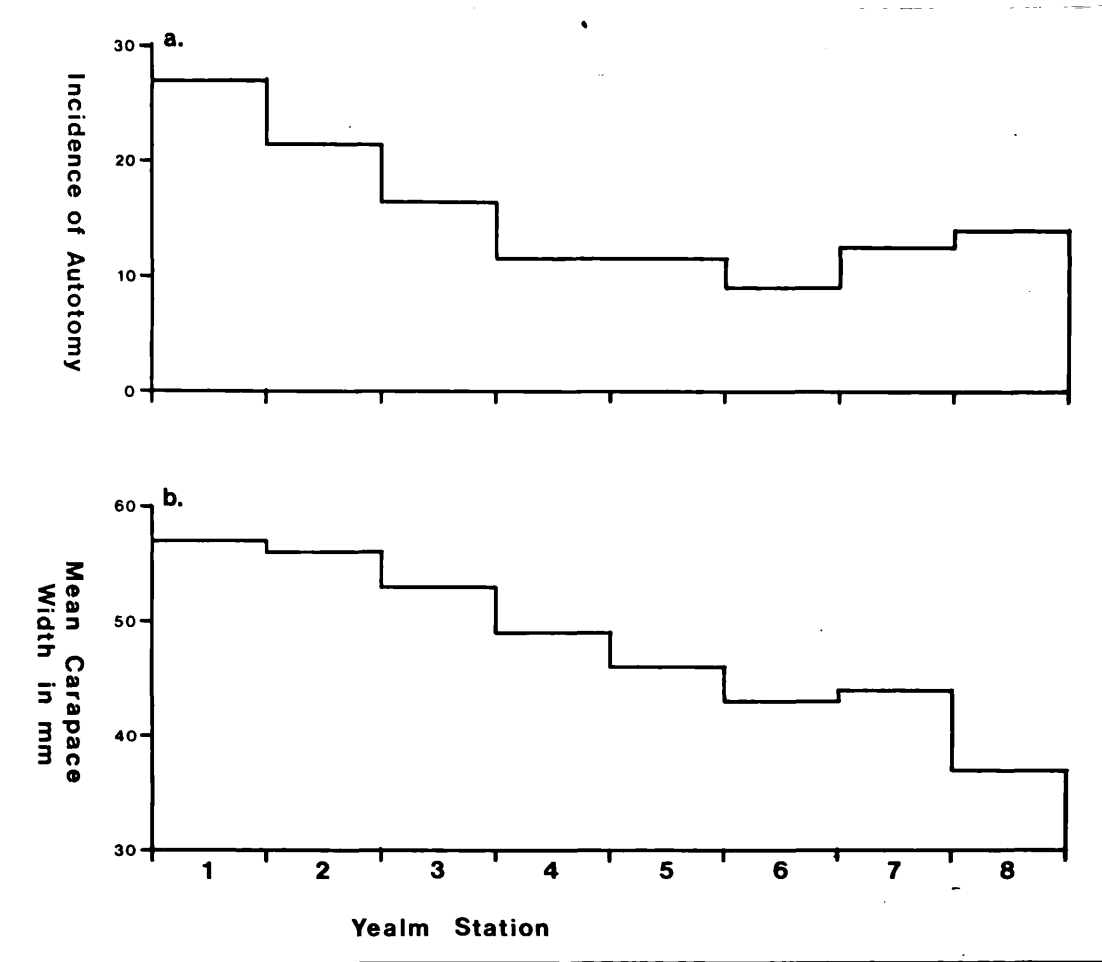

towards the mouth of the estuary.

Although the correlation between mean (\bar{x}) size of crabs and the incidence of autotomy at each station is significant, we are still left with the increase in the incidence of autotomy at the top two stations (Fig. 4a). These two stations are exposed at low water (Fig. 1). It is possible that many crabs, especially larger individuals, move downstream with the falling tide, whilst others may bury themselves in the mud. This area of the estuary is frequented by large numbers of waders, gulls and other birds during low water. The larger birds could easily take crabs of a considerable size. Such predation in the upper reaches of the estuary may account for the increased incidence of autotomy, even though the crabs tend to be smaller (Fig. 4b).

Analysis of the seasonal trends shown by *Carcinus* in the Yealm estuary

The section above has dealt with some basic information about the incidence of autotomy in *Carcinus* caught in the Yealm estuary between February 1976 and January 1977 and treats the combined data from 13 monthly samples without regard to variation in the numbers of crabs, their size, sex or incidence of autotomy, from month to month or season to season.

Fig. 5b shows the actual number of crabs caught in the Yealm estuary for each monthly sample. Fig. 5a shows the same data when the number of crabs caught at each station has been adjusted to represent one hour's trapping at each station. These figures are not to be regarded as representing crab population estimates, but will be interpreted as indicating the trends in population size. Sampling at each station for a maximum of one hour every four weeks cannot be considered to be a reliable method for estimating the Yealm estuary's crab population. Fig. 5a shows considerable variation between the numbers caught from month to month. There must be considerable random fluctuation inherent in these figures. The main point to be noted here are the low numbers of crabs caught in May, July and August and the high numbers caught from September to late December (Fig. 5a). Table 6 shows this data in terms of raw numbers of animals caught, along with the numbers of intact crabs and crabs which had lost one or more limbs.

Reduced numbers of Carcinus were captured by Naylor (1962) during May and June which he interpreted as being due to most animals moulting and therefore soft during this period when the crabs hide until the new carapace has hardened. Broekhuysen (1936) found that the main moulting period for male Carcinus was during May and June, for females, July to September. One might thus expect that the ratio of the sexes caught during these

Fig. 5 : Monthly variations in the number of crabs caught in the Yealm estuary (data from all eight stations combined) from February 1976 to January 1977.

a. Figures adjusted for one hour's trapping on each station so that each monthly figure represents an estimate of the number of crabs which would have been caught in 8 hours trapping.

b. The actual number of crabs caught.

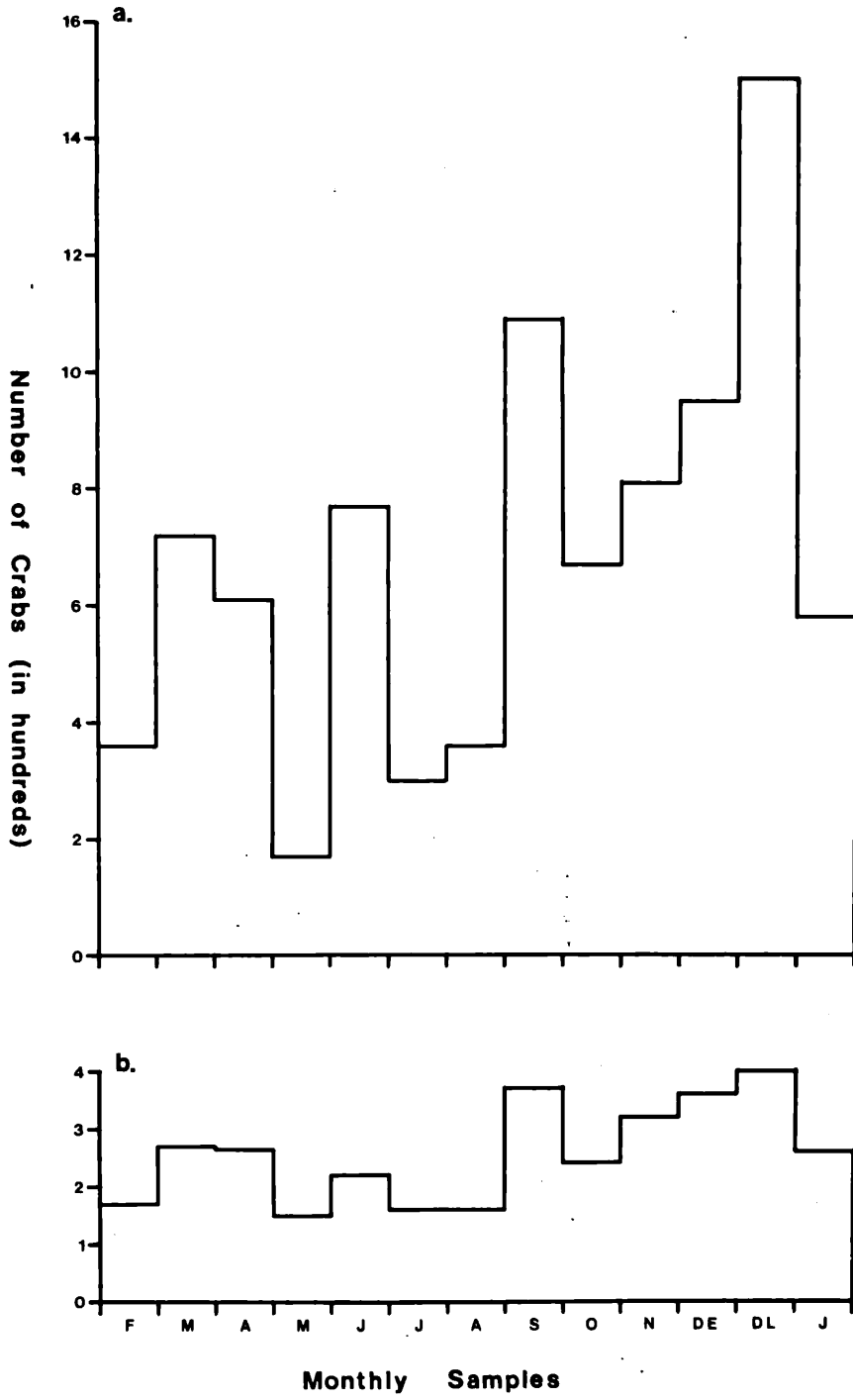

Fig. 6 : The sex ratio of Carcinus caught in each monthly sample from the Yealm estuary (February 1976 to January 1977).

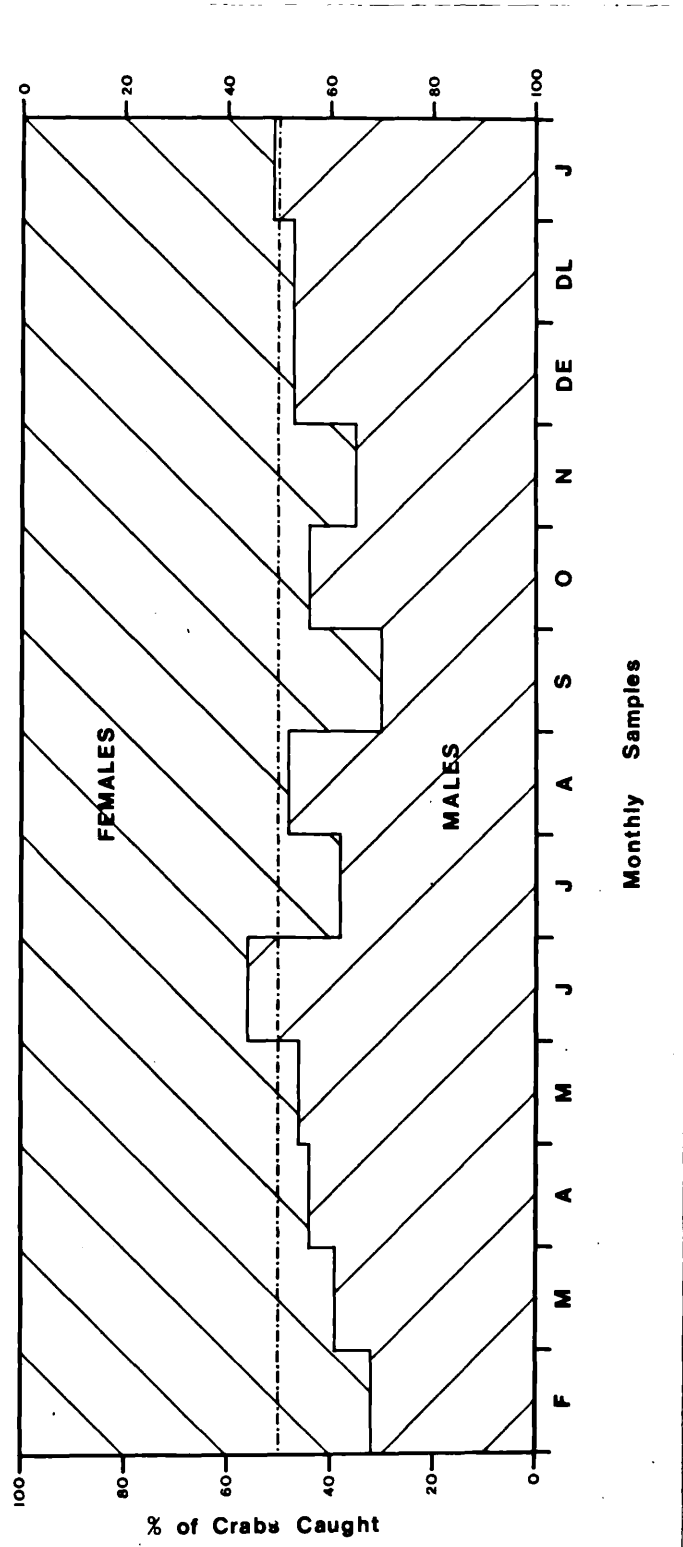

Fig. 7 : Seasonal changes in the distribution of Carcinus maenas within the Yealm estuary from February 1976 to January 1977. The number of crabs caught at each station is expressed as a percentage of the total number of crabs caught in the estuary as a whole during that month's sampling.

x : Weather conditions prevented sampling at these stations.

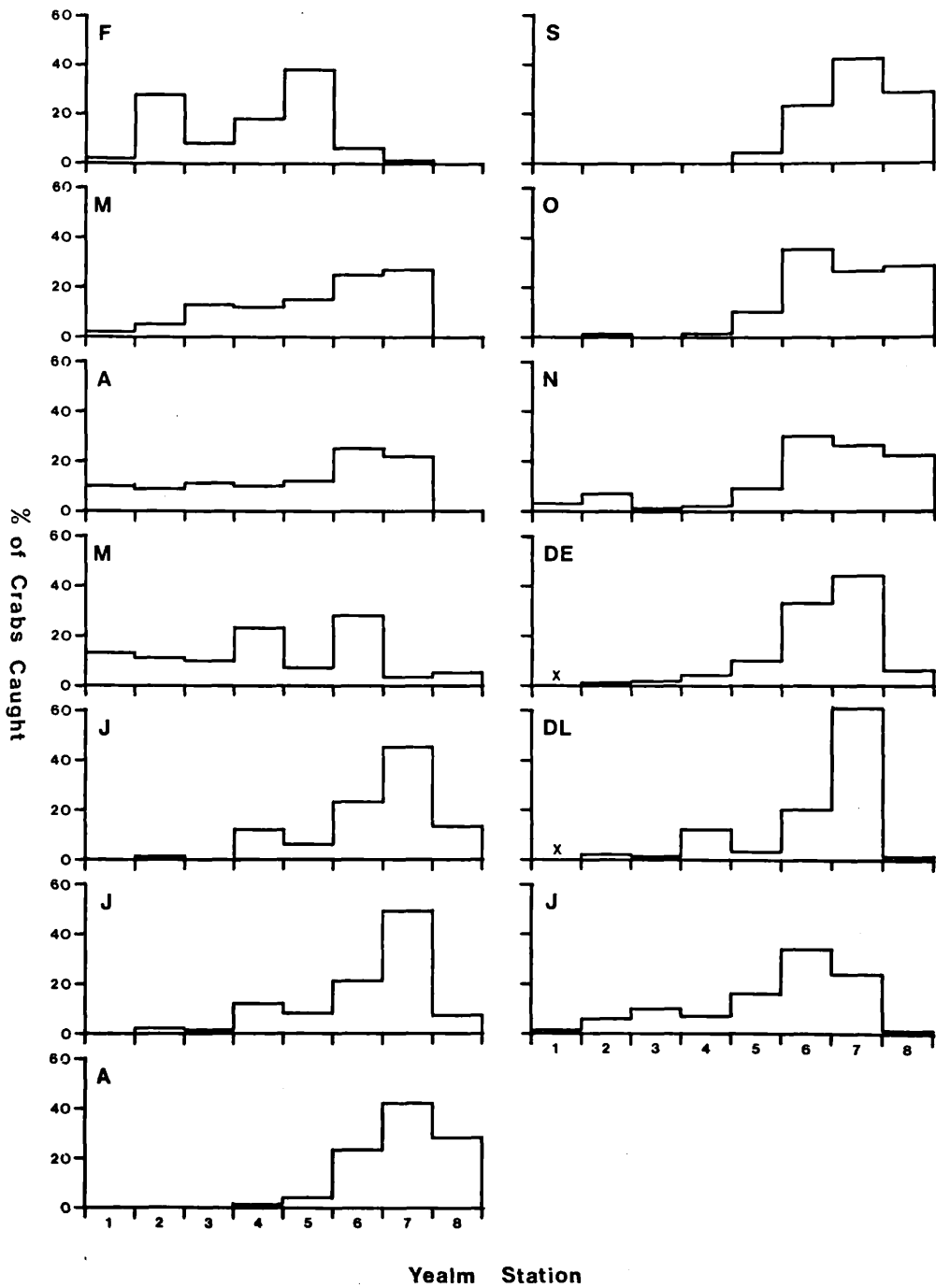

Table 6 : The number of Carcinus maenas caught in the Yealm estuary in each monthly sample between February 1976 and January 1977.

Month	Total			Males			Females		
	T	I	A	T	I	A	T	I	A
F	173	131	29	56	43	9	117	88	20
M	274	220	38	108	87	15	166	133	23
A	265	209	39	116	90	16	149	119	21
M	150	114	25	68	46	14	82	68	11
J	220	169	33	123	88	23	96	81	10
J	164	126	29	62	47	12	102	79	17
A	159	129	25	77	61	13	82	68	12
S	371	324	32	114	99	9	257	225	23
O	237	204	25	105	86	15	132	118	10
N	317	267	37	110	97	9	207	170	28
DE	356	300	44	167	140	21	189	160	23
DL	397	328	53	187	149	25	210	179	28
J	260	217	31	132	104	22	128	113	9

T : The number of crabs caught in the estuary from all eight stations.

I : The number of intact crabs.

A : The number of crabs which have lost one or more limbs.

periods might reflect this. If the individual crabs hide when soft, fewer should come to the net and thus the proportion of males caught should be reduced during May and June, the proportion of females reduced during July to September. Fig. 6 shows that the sex ratio does vary from month to month, but no regular pattern is visible, overall more females are caught than males, but the changes expected during the moulting periods are not shown.

Naylor (1962) found that large Carcinus moved up and down the shore with the tide, and that during the summer months many remained stranded on the shore to hide under stones and seaweed, but during the winter months they all remained in the deeper water off shore. In this study the effects of the tides upon crab distribution have been controlled by sampling at roughly the same point in the tidal cycle at each station, around high water. Fig. 7 shows the distribution of crabs in the Yealm estuary for each monthly sample at or around high tide. It is expected that the distribution would change as the tide falls and the upper part of the estuary drains (Fig. 1), but these figures are interpreted as representing a reliable picture of the relative distribution of the crab population within the estuary at these times.

The main points in Fig. 7 can be summarised as follows :

1. In the late winter and spring (F-M) crabs are fairly evenly spread along the length of the estuary, but are absent from the top station, 8.

2. In the summer (J-S) the population gradually concentrates in the upper reaches of the estuary.

3. In the autumn and early winter the population gradually spreads downstream and vacates the top station, 8, large numbers of crabs are still caught at station 7.

Although there must be some migration of crabs into and out of the estuary, it is tempting to consider those within the Yealm estuary as a discrete population. Certainly in the summer months this may be so when the lower part of the estuary is virtually devoid of animals (Fig. 7). In winter and spring there is presumably some downwards and outwards migration to the warmer deeper water, reversed in spring as the water in the estuary warms. Table 7 shows the temperature (in °C) of water samples taken from the bottom of the water column at each station when trapping was taking place. None of these temperatures are low enough to limit the distribution of Carcinus (Broekhuysen, 1936). The general trends are for the mouth to be warmer than the top of the estuary during winter, and the top warmer than the mouth during summer.

The changes in the distribution of Carcinus over the seasons, shown in Fig. 7 can be explained as follows :

1. In the spring, the crabs are spread along the estuary, ^{and} as the water temperature rises they gradually move upstream for the summer and autumn to feed on the mud flats.

2. The crabs move downstream again in the autumn to the warmer deeper water lower in the estuary.

The long, hot and dry summer of 1976 occurred during this year of sampling. The weather did not break until September, and the autumn and winter, although wet, were relatively mild, which could explain why, although some of the crabs moved downstream, a large number remained in the upper reaches of the estuary until the end of December (Fig. 7).

The absence of crabs from station 8 during winter months, while large numbers can still be caught at station 7 may be explained as follows; all samples were taken during high water when the upper part of the estuary is flooded (Fig. 1). The crabs move up with the tide from below station 6 at low water, to forage on the submerged mud flats at high water. ~~Although~~ During the summer the crabs would not necessarily be harmed when stranded by the falling tide by burrowing into the mud; ~~Such~~ Such behaviour is, ~~however,~~ probably not safe in winter months because of low temperatures. In winter months crabs would be able to reach station 7 on the rising tide and still return at low water to the deeper water below Steer Point (Fig. 1). Migration to station 8 would be dangerous as it would

Table 7 : Bottom water temperatures (in °C) taken at the same time as crab trapping on each station in the Yealm estuary from February 1976 and January 1977.

Month	Station							
	1.	2.	3.	4.	5.	6.	7.	8.
Feb.	8.2	8.2	7.8	7.6	8.0	8.0	7.4	7.0
Mar.	7.2	7.2	-	7.2	7.0	-	-	-
Apr.	9.5	9.6	9.5	9.8	9.1	9.6	10.0	11.4
May	11.2	12.0	11.0	12.6	12.6	12.2	13.7	14.8
June	14.2	14.8	14.6	15.0	15.6	15.2	16.0	19.4
July	17.0	17.5	17.6	17.8	19.2	18.7	19.5	21.2
Aug.	15.5	15.6	16.2	16.5	16.2	16.0	17.5	18.0
Sept.	16.8	16.8	17.0	17.0	16.8	16.8	16.8	17.0
Oct.	16.2	15.8	16.0	16.0	16.0	15.8	16.0	16.2
Nov.	13.2	13.6	13.4	13.8	11.8	12.0	10.6	10.0
Dec.E.	-	11.2	11.0	11.0	10.6	10.0	9.8	8.0
Dec.L.	-	8.8	8.8	8.6	7.8	8.0	7.8	7.8
Jan.	8.8	8.8	9.0	9.0	8.6	8.6	9.0	8.5

Fig. 8 : The size distribution of male Carcinus caught in the Yealm estuary for monthly samples from February 1976 to January 1977. The numbers are expressed as the number of males in each size group as a percentage of the total number of males captured in the estuary as a whole during that month's sampling.

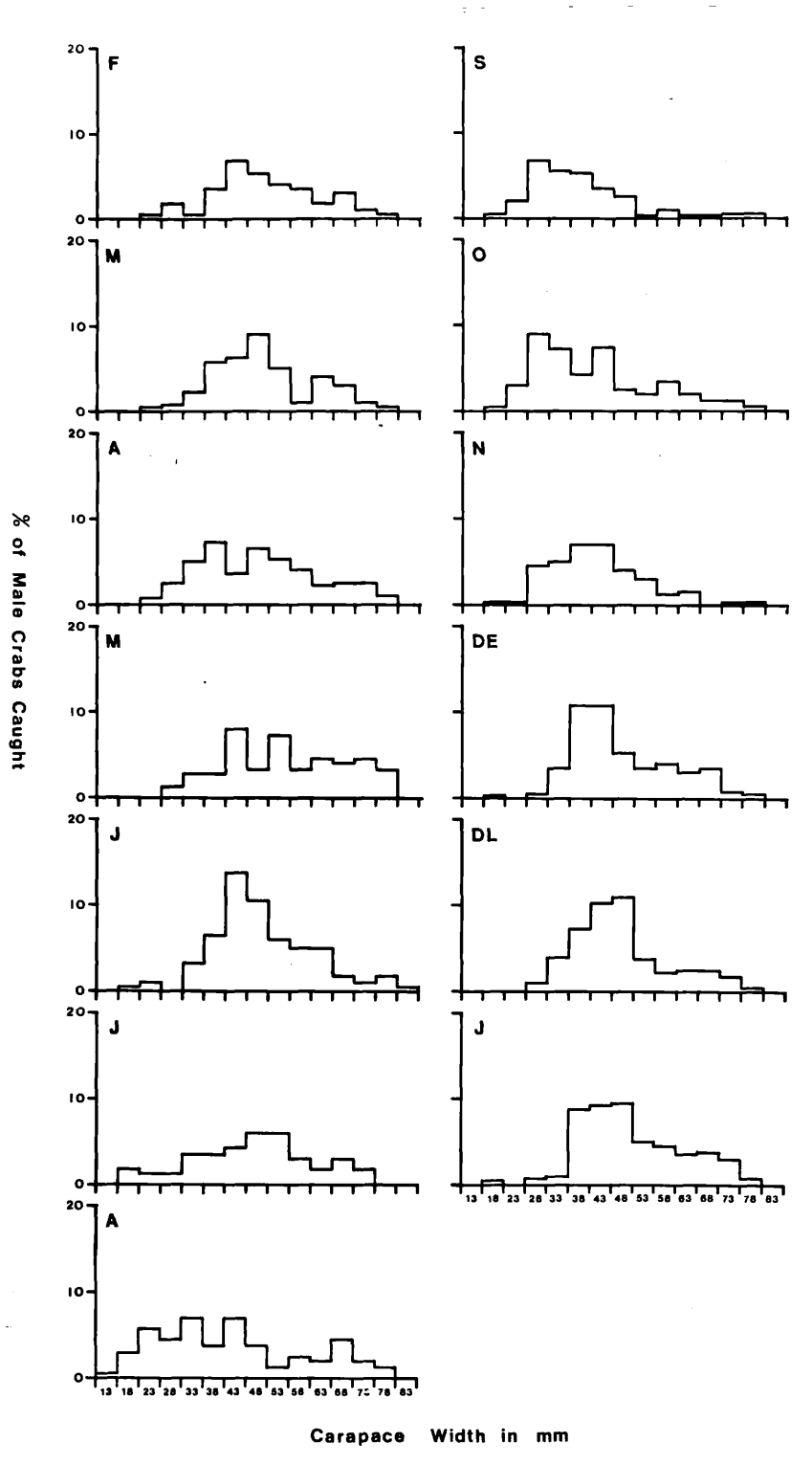
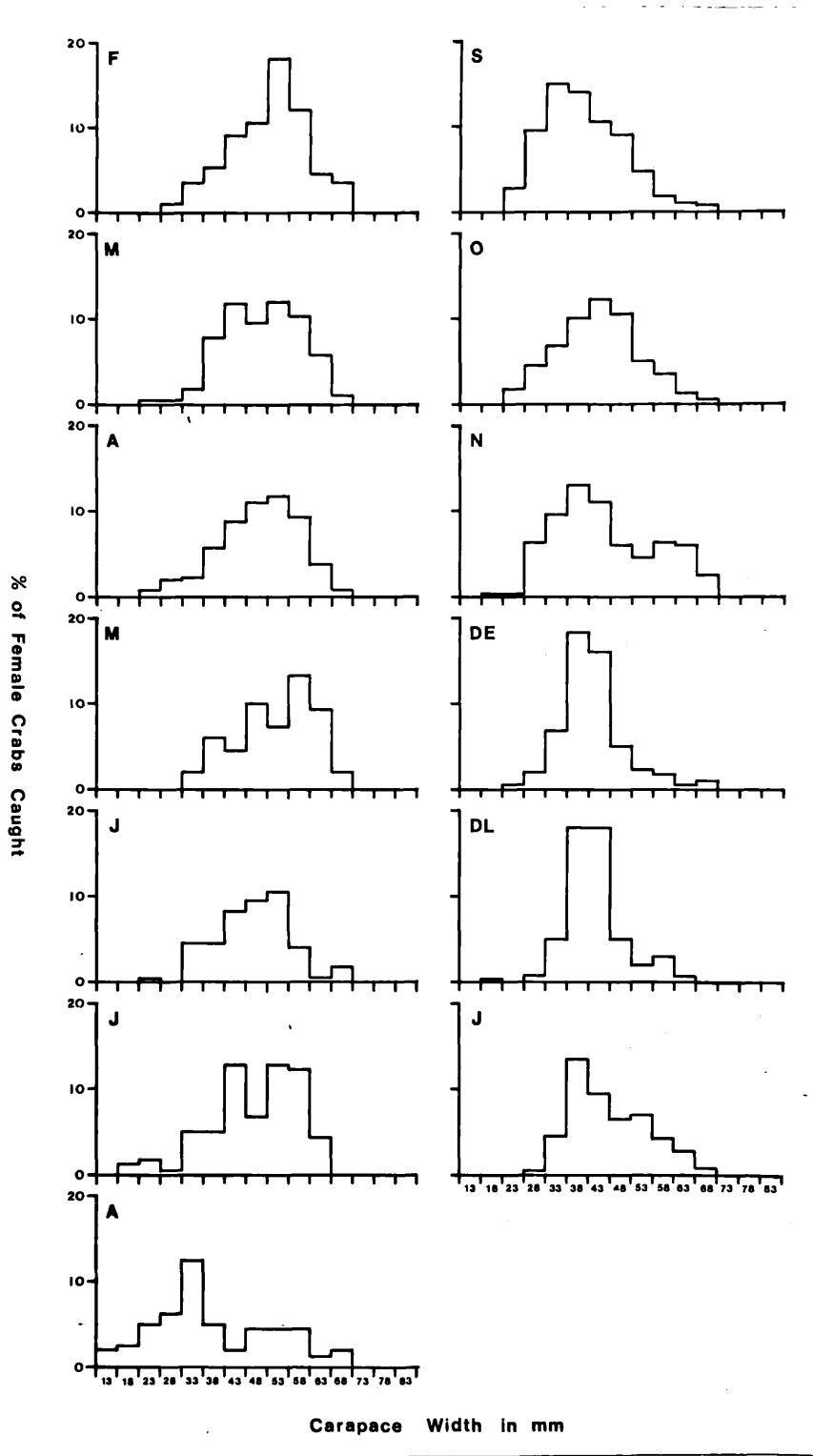

Fig. 9 : The size distribution of female Carcinus caught in the Yealm estuary for monthly samples from February 1976 to January 1977. The numbers are expressed as the number of females in each size group as a percentage of the total number of females captured in the estuary as a whole during that month's sampling.



increases the chance of being stranded at low water.

Figs. 8 and 9 show the size distributions of crabs caught each month over the whole estuary. Although the statistical allocation of year classes to this data has not been attempted, some trends are visible.

Even over this relatively short period of only one year's sampling, it can be seen that groups in the size distributions do move to the right on the graphs as the months pass and the crabs grow (Figs. 8,9). From June onwards, small crabs (\leq 25 mm carapace width) appear and increase in numbers. Eggs fertilised the previous autumn hatch in the late spring to spend some time as planktonic larvae, settle, metamorphose, and grow relatively rapidly, moulting frequently, to reach carapace widths of approximately 30 mm for females and 36 mm for males by their first winter (Broekhuysen, 1936). The group of small crabs which appear first in June (Figs. 8,9) grow rapidly (moving to the right on the graphs) to attain similar sizes as suggested by Broekhuysen (1936) by the winter months (Figs. 8,9).

These young crabs rapidly make up a significant proportion of the population, which had previously been centered around the middle of the size distribution (Figs. 8,9). At the upper end of the size distribution, representing the oldest individuals, large crabs are present until September (Figs. 8,9) when there is an

increase in the captures of small crabs. The large crabs are no longer captured and may be assumed to be absent from the estuary.

Naylor (1962) found that the larger crabs disappeared from his samples after September. There are two possible explanations, these large crabs may migrate out of the estuary in the autumn to deeper water offshore, or as suggested by Naylor (1962), the autumn is the prime mortality time for the larger individuals at the end of the main moulting season from June to September.

The seasonal variation in the incidence of autotomy (expressed as the percentage of crabs which have lost one or more limbs compared to the total number of crabs caught) is shown in Fig. 10a for both sexes, and Figs. 10c,e for separated sexes. It can be seen from Fig. 10a that the incidence of autotomy is between 14-17% of the number of crabs caught until September, when the incidence drops to less than 9%. In the following months it gradually rises again. An explanation for this relatively sudden drop in the incidence of autotomy is required.

When the data is separated for the different sexes (Fig. 10c,e) the incidence of autotomy can be seen to vary more from month to month, and on the whole is greater for males than females. Even so, for both sexes there is a drop in the incidence of autotomy in September (Fig. 10c,e). It was shown earlier that there is a significant relationship

Fig. 10 : Seasonal variation in the incidence of autotomy in Carcinus in the Yealm estuary.

a,c,e : The incidence of autotomy (the percentage of crabs which have lost one or more limbs) in each monthly sample.

b,d,f : Mean (\bar{x}) size of crabs caught in each monthly sample.

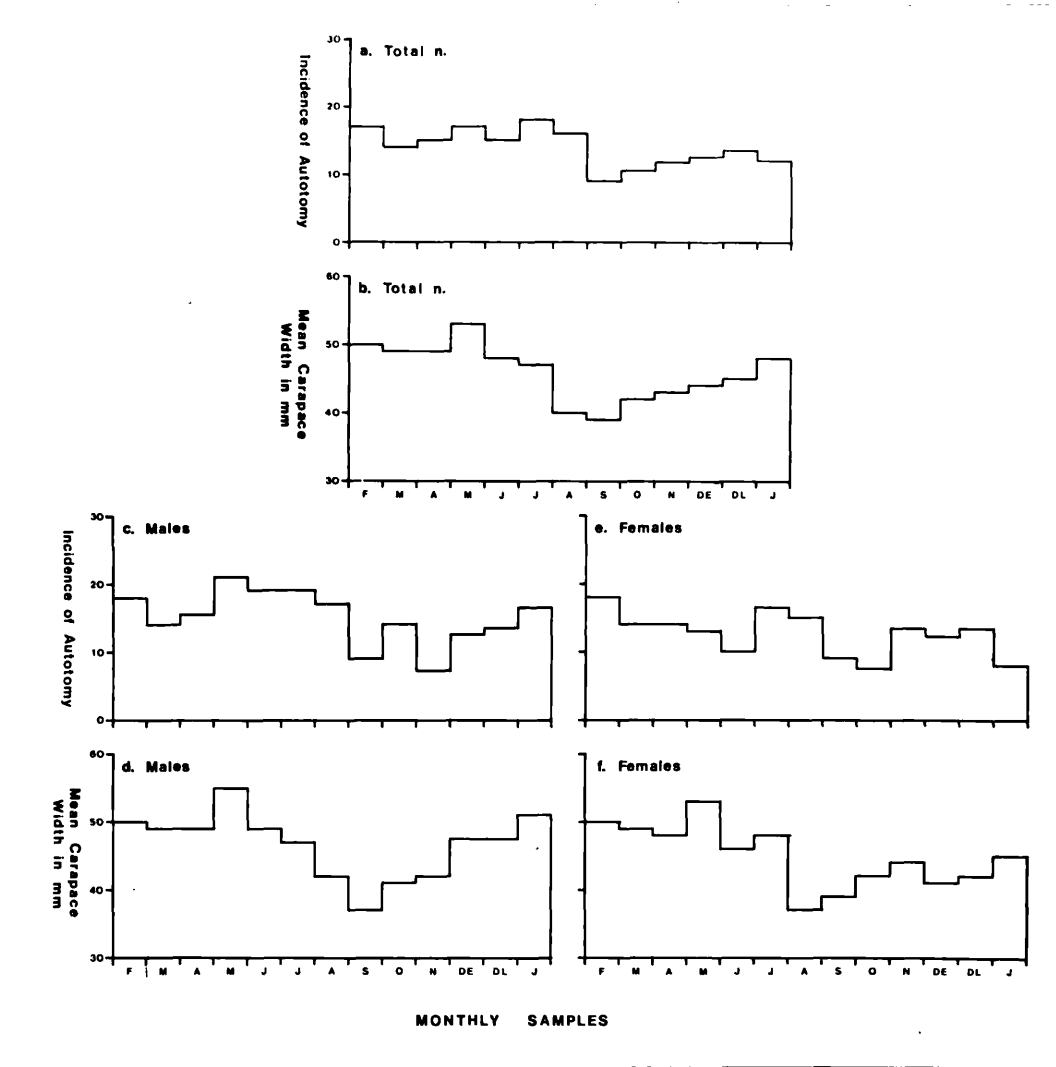
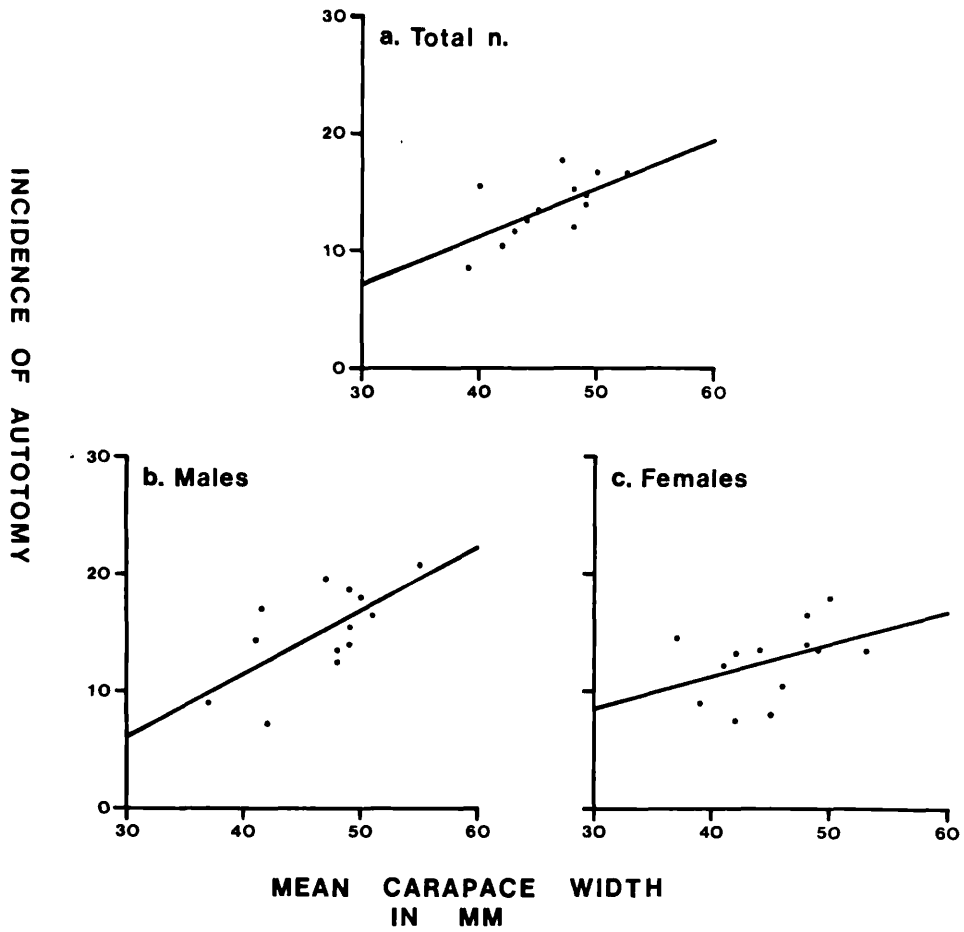

Fig. 11 : The relationship between the incidence of autotomy and the mean size of crabs caught in each monthly sample.

a. Total number of crabs, both sexes. Regression line fitted, $Y = -5.17 + 0.41X$, $P \leq 0.02$.

b. Males. Regression line fitted, $Y = -10.1 + 0.54X$, $P \leq 0.01$.

c. Females. Regression line fitted, $Y = 0.25 + 0.27X$, not significant.



between the incidence of autotomy and crab size (Figs. 3,4). If the mean size of the crabs caught in each monthly sample is plotted below the incidence of autotomy for that month, as in Fig. 10b,d,f there is fairly good agreement between the histograms, for the mean size of crabs declines during the autumn and rises gradually in the winter. Statistical analysis of these two groups of data with Kendall's tau correlation test, shows that comparing the mean (\bar{x}) size and incidence of autotomy for each monthly sample resulted in significant correlations for the total number of crabs caught ($P \leq 0.001$), for males alone ($P \leq 0.02$) and also for females alone ($P \leq 0.05$).

These relationships are shown more clearly in Fig. 11, where the incidence of autotomy and the mean size of crabs in each monthly sample are plotted against each other. Regression lines have been fitted to this data, and for all crabs and males alone, the regression coefficients are statistically significant (Fig. 11a,b), while statistically insignificant for females alone (Fig. 11c). We have seen that the relationship between size and the incidence of autotomy is not as strong for female crabs as it is for males. The regression lines fitted in Fig. 11, used as an expression of the incidence of autotomy, the percentage of crabs lacking limbs compared to the number of intact individuals caught each month. A similar procedure was used to construct the

histograms in Fig. 3, where it can be seen that for female Carcinus (Fig. 3b) the relationship between the incidence of autotomy and size only becomes obvious in crabs greater than 50 mm carapace width, while for males (Fig. 3a) the relationship appears to hold over virtually the whole size range. Therefore we might expect, as seen above (Fig. 11c), a less positive correlation between size and incidence of autotomy in the monthly samples of female crabs which is not shown by the stricter statistical analysis done with Kendall's tau test using the raw scores.

DISCUSSION

This ^{study} is based upon the observation of limbs missing from crabs caught in a baited trap. From such data can be estimated the incidence of autotomy within the population of crabs at the time of sampling. Autotomy is not a final or static state. Once a damaged limb is lost, a new limb begins to regenerate. The process of regeneration of crustacean limbs has been extensively studied (Paul, 1915; Bliss, 1961; Weis, 1976) and has been divided into several growth stages (Bliss, 1961). The main point relevant to this investigation is that for a regenerate ^{at} limb to attain full size, the crab must moult at least once. Therefore in this context, autotomy may be regarded as a process which enables the animal to discard a damaged limb in preparation for the growth of a new and fully functional replacement.

The chance to replace a limb is therefore related to the frequency of moulting. Most crab larvae settle in the late spring, April-May (Shen, 1935; Broekhuysen, 1936), metamorphose and reach a carapace width of 30-36 mm by the end of the same autumn after 11-12 moults (Broekhuysen, 1936; Demeusey, 1958). Older crabs moult less frequently, at most twice a year (Carlisle, 1957), which is probably reduced to once a year for older individuals, who eventually become anecdytic following a terminal moult, so the oldest individuals will not have the chance to replace lost limbs.

It might be expected that numbers of crabs with limbs missing would increase with the size, and therefore the age, of the individual as the opportunity to replace the limb declines. Among male crabs, this is so (Table 1b, Fig. 3a). Female Carcinus caught in this study show a more complex relationship. The smallest individuals (Table 1c) show a very high incidence of autotomy at the time when they should be able to replace the limb very rapidly; medium sized individuals show little variation in the incidence of autotomy over a wide size range, the incidence of autotomy only increases again for the oldest individuals (Fig. 3b). In both sexes, however, the relationship between size and the incidence of autotomy is statistically significant. The relatively few small females captured (Table 1c) may have provided a bias in the assessment of the percentage of female crabs with autotomised limbs, but an alternative possibility is that the smaller individuals have a more delicate cuticle which would be more liable to damage.

Paul (1915) found that the naturally occurring incidence of autotomy varied with the size of the crabs, ranging between 25-50% of Carcinus having lost at least one limb. McVean (1976) grouped limb loss and regenerates together to obtain a figure of 44% of Carcinus captured, not intact, for sub-littoral individuals. The base incidence of autotomy from all of the Carcinus captured in this investigation is 13.2% (Table 2), a figure considerably less than found by either Paul (1915) or

McVean (1976). Paul (1915) sampled from the inter-tidal zones of two separate rocky shores and suggested that this rough environment caused most of the autotomy which he observed. McVean (1976) sampled inter-tidally on a rocky shore and then from a sheltered muddy shore, and found that the incidence of autotomy was reduced in the latter environment. He also found in both inter-tidal samples that females were more susceptible to autotomy than males, while for a sub-littoral sample the situation was reversed. In this investigation, stations 1-6 are sub-littoral, station 7 and 8 littoral but sampled at high water (Fig. 1), and as found by McVean (1976) males show a greater incidence of autotomy than females (Table 2).

Both Paul (1915) and McVean (1976) sampled from harsh environments which could account for the high incidence of autotomy observed by them, when compared with these results (Table 2). Even McVean's (1976) sub-littoral sample was taken from the harbour of a small fishing port where the crab population is probably concentrated, feeding upon the offal cast out by the local fishing boats. In this case, it is possible that a high level of interactions between crabs might have resulted in an increased incidence of autotomy. In the Yealm estuary there is a range of substrate conditions and no artifactual cause for the concentration of large numbers of crabs. There is, in fact, a negative correlation between the numbers of crabs caught and the incidence of

autotomy in the samples taken in this investigation ($P \leq 0.05$). Paul (1915) and McVean (1976) sampled from situations where the incidence of autotomy might be expected to be high, rocky shores and dense populations. This study may instead be regarded as examining a more natural state for the animal. Apart from the river mouth where the substrate is rocky and the incidence of autotomy correspondingly high (Fig. 4a), the environment provides few chances of damaging a limb, and the population shows no areas of exceptionally high concentrations of crabs.

The incidence of autotomy is fairly constant for most of the year, except during the autumn when it abruptly declines from between 14-17% down to 8-9%, gradually rising again during the winter months (Fig. 10a). The incidence of autotomy for the combined sexes is closely related to the mean size of the animals caught (Fig. 11a) so that at the same time as the incidence of autotomy is reduced, the mean size of the crabs caught declines (Fig. 10a,b). The decline in the mean size of crabs captured during the autumn results mainly from the increase in the numbers of younger, smaller individuals which settled the previous spring, and also from the absence of most of the older, larger crabs (Figs. 8,9).

Naylor (1962) noticed a similar decline in the mean size of crabs caught in the autumn, which he explained as due to the high mortality of larger crabs at the end of the peak moulting season. A similar explanation could

hold for part of the decline noted here, where the largest crabs are more likely to be observed with missing limbs (Fig. 3) and their absence from the population shown by the decline in the mean size of crabs caught, would decrease the likelihood of observing crabs with missing limbs, reducing the incidence of autotomy observed. Parallel with this explanation could be the influence of the moulting season. Peak moulting ending^s in the early autumn (Broekhuysen, 1936, Carlisle, 1957) so that most crabs will have recently replaced any limbs which they may have lost. Assuming that the probability of losing a limb remains relatively constant throughout the year the chance of observing an autotomised limb would increase as time passes since the last moult. At the end of the moulting period most crabs would not have had the chance to lose limbs, with a resultant decline in the incidence of autotomy. As time passes, circumstances causing autotomy are more likely to be met by the crab and the incidence of autotomy should gradually rise (Fig. 10a).

The immediate cause of autotomy in most crustaceans is injury to the limb (McVean, 1975). For some species only slight disturbance is sufficient to cause autotomy (Wood & Wood, 1932, Hoadley, 1934), in most brachyuran crabs, however, damage has to be considerable, involving the main nerve trunks within the limb (Hoadley, 1937, Easton, 1972). Damage can be caused in a variety of ways,

in the environment by the movement of stones and rocks (Paul, 1915, McVean, 1976), by other crabs, or by predators. In the foremost case the value of the reflex could be to prevent blood loss (Paul, 1915) or as has been recently suggested, to prevent the loss of valuable metabolites (Raja et al., 1976), allowing a damaged limb to be replaced by a fully functional regenerate. In the last two cases, where interactions between animals could result in limb damage sufficient to cause autotomy, it is tempting to ascribe the function of escape to the reflex. Autotomy would allow the individual crab to leave a portion of it's body in the grasp of a predator or another crab, and escape. Some crabs have taken the reflex further and attack a threatening object, autotomise the chelipeds and escape (Robinson et al., 1970), ^{but} this _^behaviour has not been observed in Carcinus.

In the Yealm estuary we have these three causitive agents to consider. Substrate likely to cause autotomy is only found in the lowest reaches of the estuary near to the mouth (Fig. 1) and since all crabs were sampled sub-littorally, the effects of wave action are less likely to be felt and thus there was a less harsh environment than was examined by Paul (1915) or McVean (1976). Although the incidence of autotomy is higher in this part of the estuary than others (Fig. 4a), it is still less than observed by either Paul (1915) or McVean (1976).

Interactions between crabs must to an extent be dependent upon the density of the population. If we are to regard the numbers of crabs caught as at least representative of the density of the population, it would indicate that although some autotomies must result from such interactions, the population density in the Yealm estuary never reaches a level where this becomes a major influence upon the incidence of autotomy, which it might have been for the harbour population examined by McVean (1976). Interactions between crabs may however provide an explanation for the greater incidence of limb loss in males than females (Table 2) where the more aggressive behaviour of males results in an increased probability of damage sufficient to cause autotomy occurring.

The last category of autotomy-causing agents is predation. It is difficult to definitely prove that escape is a valid agent for the evolution of the autotomy reflex, however, it is an extremely attractive hypothesis with value for the survival of the individual. The effects of predation upon a population of sub-littoral crabs must decline as the crabs increase in size, when fewer animals would be able to tackle a large crab. Predation in these circumstances probably occurs at a fairly steady rate and must account for a proportion of the autotomies observed. In the upper reaches of the Yealm estuary where sampling occurred in the littoral

zone (Fig. 1) predation by large flocks of waders, gulls and other birds could account for the slight increase in the incidence of autotomy observed from stations 7 and 8 (Fig. 4a), as a proportion of the crabs would remain, at least during summer months (Naylor, 1962) on the mud flats exposed during low water.

SECTION 2 : THE MECHANISM AND NERVOUS CONTROL
OF LIMB AUTOTOMY IN THE HERMIT CRAB Pagurus
bernhardus (ANOMURA) AND THE SHORE CRAB
Carcinus maenas (BRACHYURA).

INTRODUCTION

It is only in recent years that the techniques of electrophysiology have been applied to the study of autotomy of crustacean limbs. Previous investigations (reviewed by McVean, 1975) concentrated upon the anatomy of the breakage plane and the BI muscles, and not surprisingly, considering the complexity of the autotomy region of crustacean limbs, a number of incorrect hypotheses were suggested. However, several important points did arise from some of the more experimental examinations. MacCulloch (1824) found the plane of weakness in the basi-ischiopodite (BI) region of Carcinus, and Fredericq (1883) showed that autotomy can be mimicked by pulling on the tendon of the anterior BI levator muscle (AL) when movement of the BI and peripheral limb is prevented. He also demonstrated that the breakage plane is not the weakest structural point in the limb since hanging a considerable weight onto a limb resulted in separation of a limb joint rather than snapping of the breakage plane (Fredericq, 1892). He concluded that the anterior levator muscle must act upon the dorsal BI in a specialised manner to achieve autotomy. Wood & Wood (1932) rejected Fredericq's hypothesis (1892) yet presented the same mechanism. This situation arose because while Fredericq (1892) required a resistance to limb levation "external" to the limb, Wood & Wood (1932)

provided a resistance "within" the limb by supposing that the BI could be jammed up against the dorsal rim of the coxa. The main point, however, was that autotomy requires that levation of the limb be prevented so that contraction of the AL muscle approaches an isometric state.

McVean (1970, 1973, 1974), working on Carcinus, was the first to apply electrophysiological techniques to the study of limb autotomy. Examining the AL muscle, Fredericq's autotomiser, he measured the maximum force that could be exerted by the muscle upon the BI and then the force used to obtain autotomy. Since on several occasions the "autotomy force" was considerably less than the maximum force shown to have been exerted by that muscle without causing autotomy, he concluded that the differentiation of locomotion and autotomy was not just a result of extra force exerted by the AL muscle, but that prior to autotomy something happened to alter the influence of the AL muscle upon the plug region of the breakage plane (McVean, 1973). Carefully examining the musculature of the BI joint, he described the small posterior BI levator muscle (PL) in detail (McVean, 1973). The PL tendon is unusual in that it hangs perpendicularly from the dorsal rim of the BI and its muscle fibres do not run parallel to the tendon blade but at right angles to it, they originate in the dorsal coxa and insert only onto the proximal face of the tendon blade (McVean, 1973).

Thus when the fibres contract they cause the tip of the tendon blade to rotate about it's attachment to the BI rim. McVean (1974) calculated that this action would give the PL muscle a five-fold mechanical advantage. McVean (1973) also found that the AL tendon blade, ~~unlike the PL tendon, runs parallel to it's muscle fibres,~~ inserted via a flexible band onto a block of cuticle which, although flexibly linked to the BI on it's dorsal margin, was fused ~~on it's ventral edge~~ to a similar cuticle projection on the BI. When the PL tendon rotated, the close apposition of the PL tendon and the AL tendon head also caused the AL tendon head to rotate dorsally about it's flexible connection with the BI, fracturing a breakage plane between the fused ventral projections of tendon head and BI. This, he suggested, would concentrate AL muscle force onto the cuticular plug of the breakage plane to cause fracture and autotomy (McVean, 1973). Recording from the AL and PL nerves when injuring the peripheral limb, McVean (1974) found that a new large unit supplying the AL muscle fired only upon injury and caused large twitches in the muscle. Two units supplied the PL muscle, the larger phasic one was stimulated by injury (McVean, 1974).

McVean (1973, 1974) therefore, suggested that limb autotomy involved coactivation of the two BI levator muscles induced by injury inflicted on the peripheral limb, so that AL muscle force was concentrated onto the

cuticle plug by PL tendon rotation fracturing the AL's ventral connection to the BI. During other activities this fracture plane was to remain intact, spreading AL muscle force about the BI, away from the fracture plane.

In 1970, Wales and his coworkers (Wales et al., 1970) described a new type of sense organ in the Crustacea, the cuticular stress detectors (CSDs). One of these CSDs (CSD₁) is situated between the insertion of the AL muscle and the plug region of the breakage plane (Wales et al., 1971), and responds to strains exerted onto the BI by contraction of the AL muscle (Clarac et al., 1971). Clarac & Wales (1970) showed that stimulation of CSD₁ reflexly excited firing of the phasic unit supplying the PL muscle and caused the PL tendon to rotate. They suggested two hypotheses for the role of CSD₁. The first involved positive feedback from CSD₁ onto both the PL and the AL muscles, building up tension and eventually causing autotomy. The second hypothesis involved the CSD₁-PL reflex loop to support the AL muscle's levatory load and thus prevent accidental autotomy, and suggested that the PL phasic unit was active during normal locomotion (Clarac & Wales, 1970). McVean (1974) rejected both hypotheses, the first on the basis that any resistance to limb levation would thus lead to autotomy. The second, because activation of PL according to his hypothesis (McVean, 1973) initiated autotomy by fracturing the connection between the AL tendon head and the BI and he

had also shown that injury alone could stimulate the PL phasic unit. He allowed that CSD₁ could play a contributory part in the rotation of the PL tendon to initiate autotomy rather than prevent it as had been suggested by Clarac & Wales (1970).

In 1973 in her doctoral thesis, and in a subsequent publication based upon her thesis (Moffett, 1975), Moffett published her examination of the nervous control of the BI musculature during both autotomy and normal limb elevation in the land crab Cardisoma guanhumi, and opposed the mechanism for autotomy proposed by McVean (1973, 1974). Although her work was based on Cardisoma, she did examine Carcinus and could find no differences in the anatomy and actions of the BI levators or BI structure between the two species (Moffett, 1973, 1975) and careful examination of her drawings, photographs and descriptions reveal no obvious difference between the anatomy of Cardisoma and Carcinus.

The main points of Moffett's (1975) hypothesis can be summarised as follows. The AL tendon head is never fused to the BI, but instead the ventral projections of tendon head and BI form two closely abutting faces which are free to open and close with the movement of the PL tendon. Pulling the AL tendon, without PL tendon rotation, forces these projections together and she suggests, concentrates strain imposed by the AL muscle onto the cuticle plug which is the only structurally

continuous portion of the breakage plane, the rest being made up of two smooth cuticle faces (Moffett, 1975). When the PL tendon rotates, it separates the faces between the AL tendon head and the BI removing AL muscle force from the cuticle plug (Moffett, 1975). She found that injuring the peripheral limb stimulated large units supplying the AL muscle, while units serving the PL muscle were inhibited, and since the CSD_1 -PL reflex loop operates in Cardisoma, she suggested that this reflex must be inhibited by limb injury (Moffett, 1975). Though she did not record from the PL muscle during normal locomotion, she puts forward the evidence of Clarac & Wales (1970) and Clarac & Coulmance (1971) of PL activity during locomotion to support her hypothesis.

Thus, according to Moffett (1975), the PL muscle is inhibited to allow AL force to be concentrated through the abutting faces of the AL tendon head and BI to initiate autotomy, while the PL muscle is active during locomotion to open these faces and support the limb load. Her role for CSD_1 agrees with the second hypothesis put forward by Clarac & Wales (1970), her records (Moffett, 1975) show that both PL and AL units are reflexly excited by CSD_1 stimulation, and she suggests a supporting function for the PL muscle in normal locomotion, reflexly excited by excess AL muscle tension which might threaten the breakage plane.

McVean (1973, 1974) and Moffett (1975) agree, that

to cause autotomy, the force delivered by the AL muscle must be concentrated onto the plug connection in the breakage plane, while during normal activity AL force must be diverted from this point. They oppose each other, however, regarding the mechanical events influencing AL force deployment and the nervous control of the BI levator muscles which achieves both levation during locomotion and autotomy on injury.

This investigation was undertaken in an attempt to differentiate between the results obtained by McVean (1973, 1974) and Moffett (1975), to decide which hypothesis, if either, was correct. It was also undertaken to examine the sophistication and development of the autotomy reflex through the Crustacea which eventually leads to the volitional aspects of "attack autotomy" (Robinson et al., 1970), by investigating the mechanism and nervous control of limb autotomy first in the anomuran hermit crab Pagurus bernhardus and then the brachyuran shore crab Carcinus maenas.

MATERIALS AND METHODS

Animals

Part of this work was done at the Laboratory, Marine Biological Association (U.K.), Plymouth between January 1976 and January 1977, where Pagurus bernhardus and Carcinus maenas were available. In London, specimens of both species were supplied by the University Marine Station, Millport, Isle of Cumbae, Scotland and kept in an artificial seawater circulation until required.

Anatomy

The anatomy of the BI musculature in Pagurus and Carcinus was examined by dissection.

Individual Pagurus were strapped, ventral surface upwards, onto a Perspex platform, and the third left pereopod (3LP) rotated so that the anterior coxa faced upwards. This limb was held peripherally by a Palmer tendon clamp and other limbs immobilised with elastic bands. The BI muscles and their innervation were exposed by removing the anterior thorax-coxa articulating membrane and the anterior face of the coxa. The BI depressor muscle was then separated from its insertion on the ventral margin of the BI, its nerve severed where it enters the muscle and its muscle fibres separated from their origins on the ventral coxa and thorax (Fig. 12b).

Carcinus were held ventral surface upwards in a

three pronged clamp and the fifth left pereopod (last walking leg) dissected as described by McVean (1974).

The innervation of the BI muscles was traced by supra vitam staining with methylene blue (5% ~~solution~~ ^{w/v in distilled water, dilute} in seawater). The best results were obtained by injecting 1-2 ml of stain solution into the BI region of the limb a few minutes before dissection.

The insertions of the BI levator muscles and the externally visible BI cuticle structure were examined in animals held dorsal surface upwards, where the dorsal coxa-BI arthrodial membrane was removed. Drawings of the muscles and cuticle structure were traced using a Wild drawing tube (Figs. 12a, 13a,b). The internal structure of the BI, breakage plane and levator tendons was examined in limbs which had been separated from the thorax and all soft tissue removed by alternate freeze-thawing.

Scanning electron microscopy

The dorsal BI of Pagurus and Carcinus were dehydrated in alcohol, air dried, coated with gold and examined with a Cambridge Instrument Co., Stereoscan S4-10 electron microscope.

Axonal iontophoresis of cobalt chloride

The technique developed to identify the central projections of BI motor neurones by retrograde iontophoresis

of cobalt chloride is described in Appendix 1.

Recording techniques

Nerve recordings were obtained from dissected preparations of both species with suction electrodes pulled from fine plastic tubing. Usually, records were obtained from the severed ends of nerves sucked up into the electrode, but occasionally, to leave the innervation intact, nervous activity was recorded en-passant.

In Pagurus, it was possible to record from the CSD₁ afferent nerve in the normal dissected preparation, but in Carcinus, the CSD₁ sensory nerve had to be approached from the dorsal surface by depressing and clamping the limb, removing the dorsal coxa-BI arthrodial membrane, the PL tendon and muscle fibres, and severing the AL tendon, exposing the CSD₁ afferent bundle which is situated just posterior to and beneath the AL tendon head. Dissected preparations were continuously washed with cool seawater.

Glass microelectrodes, with resistances between 5-15 M Ω , filled with 3M KCl, were used to record intracellularly from PL muscle fibres. Intracellular records were obtained from crabs held dorsal surface upwards, where the muscle was exposed by removing the dorsal coxa-BI arthrodial membrane, on a few occasions, ventrally situated PL muscle fibres were recorded from ventrally dissected preparations.

Extracellular myograms were obtained by implanting into muscles 50 μ m diameter stainless steel paired electrodes, Trimel coated except for their tips (Johnson Matthey Ltd., London). Muscle responses to injury and during autotomy were recorded from restrained animals, with the electrode wires mounted in glass tubing and placed onto the relevant muscle using micromanipulators. Muscle responses during locomotion were recorded from animals that were free to move around a small tank. In Carcinus, a small Perspex platform was glued onto the crab's back and electrode wires led from it to the relevant muscles through holes pierced either through the coxa or dorsal coxa-BI arthrodial membrane. Connections from the Perspex platform led to pre-amplifiers. The whole apparatus weighed less than 5 g and did not appear to impede the movements of the crab within the tank. Hermit crabs were removed from their shells since these would disturb the electrode wires and a slightly different approach had to be applied since it was difficult to fix the platform to the animal's back because of the absence of solid cuticle for a firm attachment. Instead, the recording wires were soldered directly to the pre-amplifier input leads and part way along their length glued in a small sandwich made by cutting two slices from a wide rubber band, the rubber sandwich containing the recording electrodes was then stuck to the hermit crab's back. The electrode tips were placed as in Carcinus. The position

of the electrodes in both animals was checked by eliciting the expected resistance reflex responses to manual levation and depression of the limb about the coxa-BI joint.

All signals were amplified and displayed conventionally, nerve and extracellular myogram responses were stored on tape for subsequent filming and analysis, intracellular records were filmed directly from the oscilloscope screen.

Autotomy monitor

When recording from the muscles during autotomy, it is important to be able to fix the time of limb separation accurately. Therefore an autotomy monitor was devised. It consisted of a strain gauge attached to the limb by an elastic band, just distal to the breakage plane, so that on limb separation a DC shift is recorded on the oscilloscope screen.

Muscle weights and limb moments

The BI muscles of Carcinus were removed from the limb individually by severing each tendon from its insertion and then carefully freeing the muscle fibres from their origin. Individual muscles with attached tendons were weighed, in seawater, in sealed containers on a Sartorius semi-micro balance. The tendon was then separated from the muscle by freeze-thawing and reweighed. Its weight was subtracted from the total weight to obtain the wet weight of the muscle fibres.

The angular moment of inertia of each limb about the coxa-BI joint was calculated according to the method given by Alexander (1968).

RESULTS

I. ANATOMY OF THE BI MUSCULATURE AND CUTICLE STRUCTURE

Anatomy of the BI musculature

The limbs of Carcinus and Pagurus are each made up of six segments. The one which concerns us most in this investigation is the second segment from the thorax, the basi-ischiopodite (BI). The BI articulates with the coxa (the first limb segment) on its anterior and posterior faces and the position of the BI with respect to the coxa is controlled by two groups of antagonistic muscles. The BI levator muscles move the BI and peripheral limb upwards (levation), and the BI depressor muscle moves the limb downwards (depression).

The axial skeleton of Pagurus has been described by Pilgrim (1973) and his nomenclature for the skeletal elements is adopted here. In Pagurus there are five pairs of pereopods, the first pair form the chelae, and unlike Carcinus where the remaining pereopods are walking limbs, only the second two pairs are used for walking in Pagurus. The last two pairs of pereopods are greatly reduced, the fourth pair being involved in the balance and maintainance of shell position (Chapple, 1973) and the fifth pair of pereopods are used for cleaning the gills.

Fig. 12 : The third left pereopod (largest walking limb) of Pagurus bernhardus, the drawings were traced using a Wild drawing tube.

a. The anterior-dorsal face of the proximal BI and coxa segments of the limb (x 12) with the dorsal coxa-BI arthrodistal membrane dissected away to show the two BI levator muscles. Important parts of the BI, the breakage plane, Paul's furrow and the external soft membrane of CSD₁ are also shown.

b. The basic dissected preparation of 3LP of Pagurus (x 10) described in Materials and Methods is shown here in this drawing. Nerve records were usually obtained from the ends of severed nerve trunks which are still connected to their muscles in this drawing, with the exception of the DEP nerve, since the DEP muscle has been removed.

al, anterior levator muscle, aln, anterior levator nerve, alt, main blade of the anterior levator tendon, alth, cuticle block between the AL tendon and BI which forms the anterior levator tendon head, am, autotomy membrane which seals the retained BI stump after cuticular separation, BI, basi-ischiopodite; bp, preformed breakage plane, cb, afferent nerve of the coxa-BI chordotonal organ, csd₁, cuticular stress detector one, depn, nerve supplying the BI depressor muscle, fb, flexible band between alt and the tendon head, p, cuticular plug spanning the breakage plane, pf, Paul's furrow, pl, posterior levator muscle, pln, posterior levator nerve, plt, posterior levator muscle tendon, PNT, main peripheral nerve trunks passing through the coxa to serve the peripheral limb, ST. XII, thoracic sternite XII (Pilgrim, 1973), TG, thoracic ganglion, 2LP, second left pereopod, 4LP fourth left pereopod.

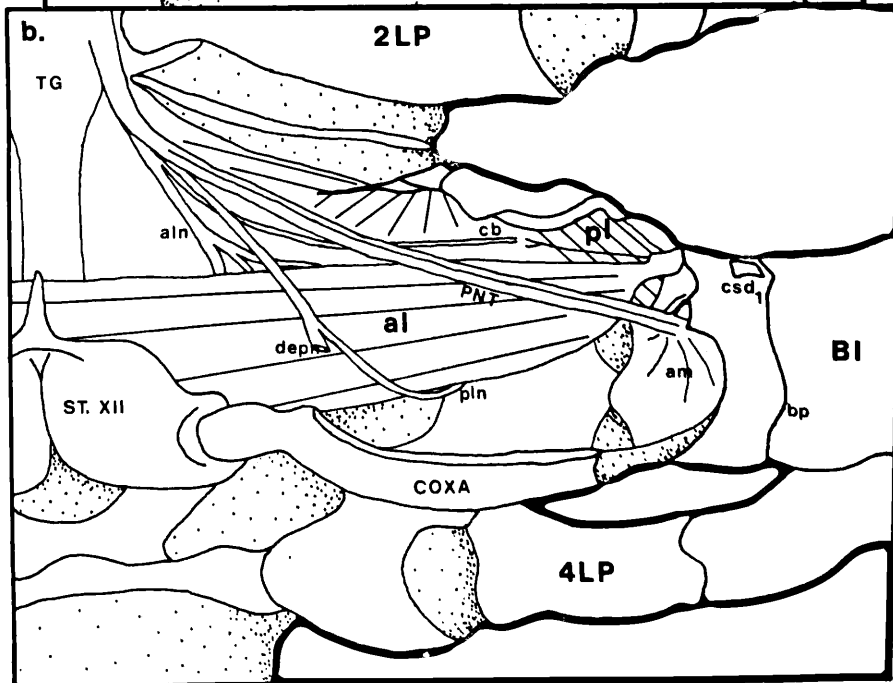
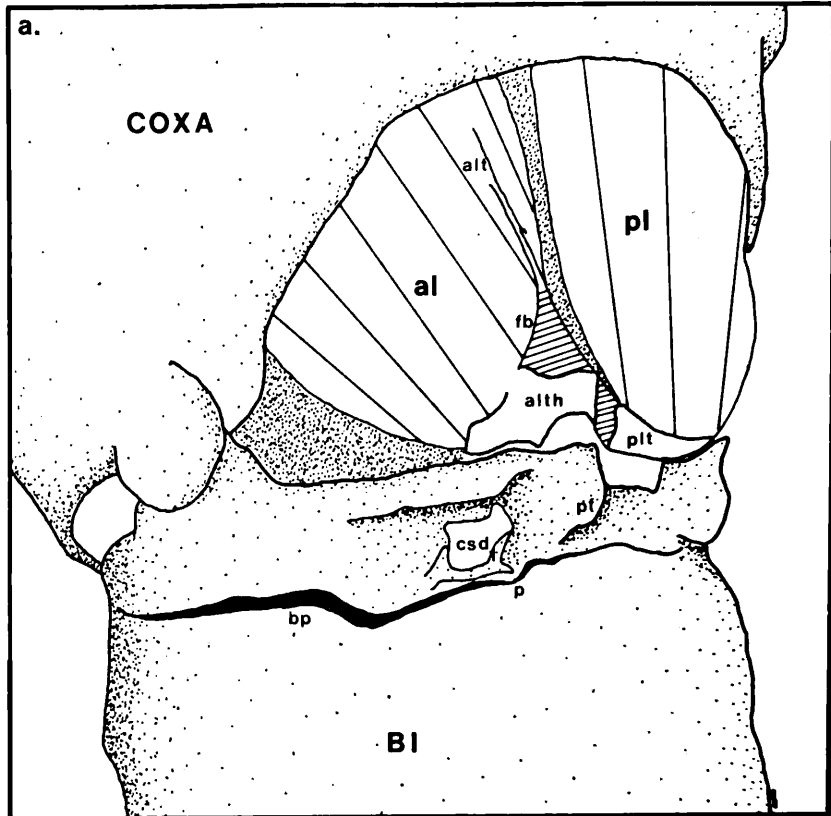

The third left pereopod, the largest walking limb, was used most often in this study since it is easy to rotate the coxa about its articulation with the thorax to reveal the large area of articulating membrane between the thorax and anterior face of the coxa. This made access to the underlying muscles and nerves much easier.

In the third left pereopod (3LP), the anterior BI levator muscle (AL) has two branches, both of which originate within the thorax. The larger posterior branch originates on the medial thoracic plate and anterior portion of sternite XII (Fig. 12b). The smaller anterior branch, which is only made up of a few muscle fibres, originates on the arthrodial membrane between sternite XIIan. and the anterior face of the coxa. The AL tendon does not insert directly onto the BI, but via a flexible band, onto a cuticle block forming the tendon head, which inserts onto the anterior dorsal margin of the BI (Fig. 12a). Most of the AL muscle fibres attach to the tendon blade, while a few muscle fibres from the anterior branch of AL insert directly onto the tendon head (Fig. 12a).

The BI depressor muscle (DEP) of the third left pereopod is not separated into distinct branches, although its origins are well separated. Part of the muscle originates just posterior to the AL muscle fibres on the medial plate of sternite XII, and a few fibres with the anterior branch of the AL muscle on the thorax-

coxa arthrodistal membrane. Most of the DEP muscle originates on the ventral coxa. All of the DEP muscle's fibres attach to a long broad tendon blade which inserts directly onto the ventral rim of the BI. Although the two antagonists, AL and DEP, share large parts of their origins ventrally within the thorax, their opposite actions result because they insert onto opposite sides of the coxa-BI articulation axis.

Unlike the AL or DEP muscles, the small posterior BI levator muscle (PL) originates wholly within the coxa. The PL tendon hangs perpendicularly into the limb from its attachment to the dorsal rim of the BI just posterior to the AL tendon head insertion, and has the outline of an inverted triangle, broad dorsally, tapering to a point ventrally (Fig. 12a,b). The PL muscle fibres which originate of the dorsal coxa, insert only onto the proximal face of the tendon blade.

McVean (1973) has described in detail the anatomy of the coxal and BI muscles of the last walking leg (fifth pereopod) of Carcinus and therefore only a brief outline will be given here.

The thoracic skeleton of Carcinus is much expanded when compared with the axial skeleton of Pagurus, the thoracic sternites form boxes to enclose the limb muscles serving both coxa and BI. The fifth pereopod has been used for most dissected investigation since in this limb

Fig. 13 : Dorsal views of the coxa-BI articulation in walking legs and chelipeds of Carcinus maenas. The dorsal coxa-BI arthrodial membranes have been dissected away to reveal the BI levator muscles. These drawings were traced using a Wild drawing tube.

a. The third right pereopod (largest walking leg) of Carcinus (x 10). This drawing shows the subdivision of the PL muscle into PPL and RPL and their separate insertions onto the dorsal rim of the BI. A group of AL muscle fibres insert directly onto the AL tendon head instead of attaching to the tendon blade (al_2).

b. The right cheliped of Carcinus (x 10) where the PPL muscle is much larger than in walking legs, the PPL tendon and its muscle fibres almost completely overlie the RPL muscle. The structure of the BI distal to the insertion of the AL muscle is similar in both cheliped and walking leg (a.), with the distinct cuticular plug, bounded by Paul's furrow and CSD_1 , running from the posterior part of AL's insertion to the plug connection in the breakage plane.

cp, approximately triangular shaped piece of cuticle in the dorsal BI which culminates in the plug (p) across the breakage plane (bp); es, area of cuticle just distal to the anterior part of the AL insertion which ventrally bears the abutting faces between the AL tendon head (alth) and dorsal BI; ppl, subdivision of the posterior levator muscle which, originating in the dorsal coxa and inserting onto a fragment of cuticle (pplt), aids limb levation; rpl, the subdivision of the PL muscle which inserts onto the proximal face of a triangular tendon (rplt) and which rotates on muscle contraction.

Other labels as Fig. 12.

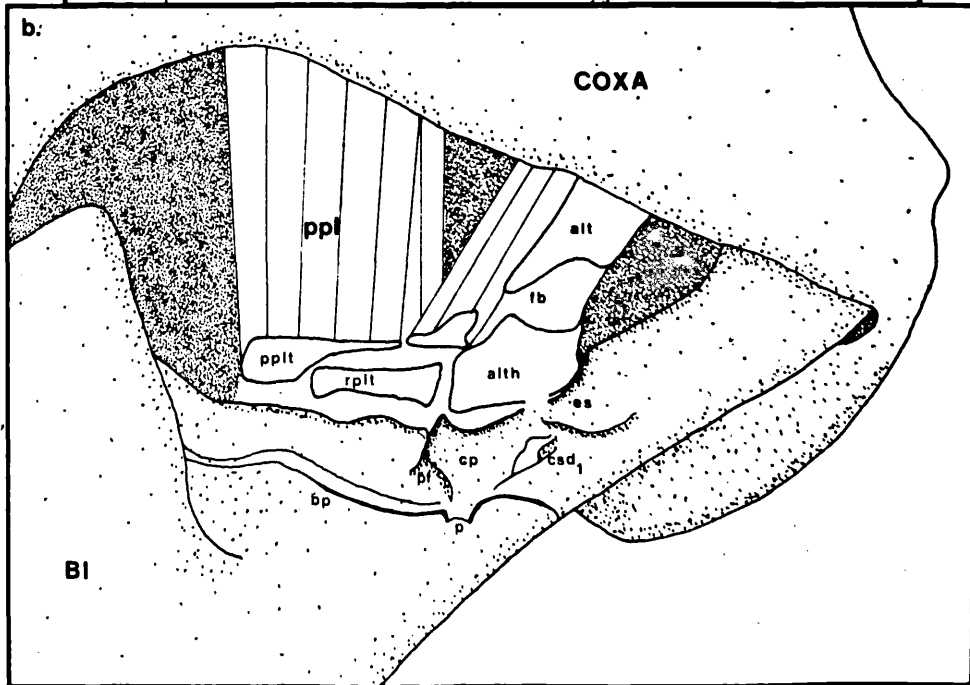
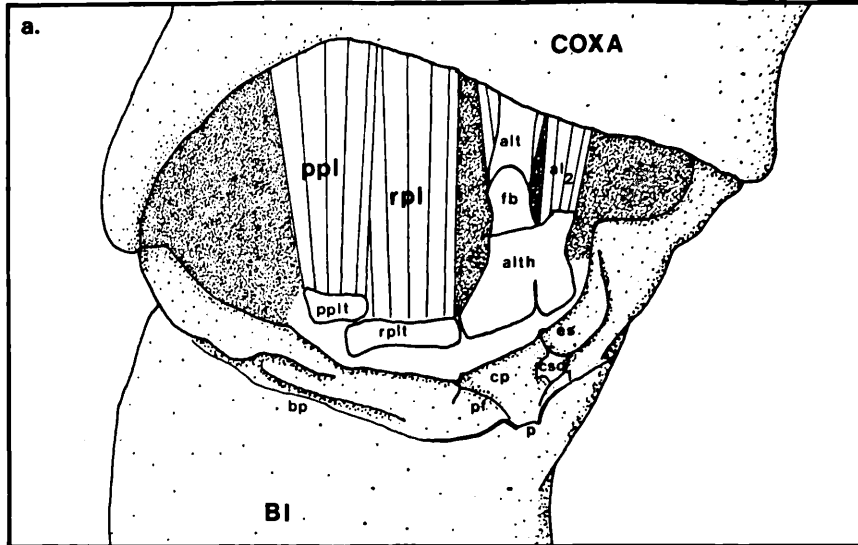

the thoracic sternal plates do not form such a deep narrow box as in other limbs, the ventral sternal plates of the fifth pereopod are instead greatly expanded and when removed, provide easier access to the muscles and nerves within the limb.

The anterior BI levator muscle (AL) of Carcinus has three main branches which originate, respectively, on the anterior endosternite wall, the central and posterior sternal plates, and a small branch on the posterior wall of the coxa. As in Pagurus, a cuticle block is interposed between the main AL tendon blade and the dorsal rim of the BI (Fig. 13a), most of the AL muscle fibres attach to the tendon blade, though a few muscle fibres do insert directly onto the tendon head to form a distinct bundle (labelled al_2 in Fig. 13a). These muscle fibres (al_2) originate, with other muscle fibres of the anterior branch of the AL muscle, on the anterior endosternite wall.

The BI depressor muscle (DEP) originates ventrally to the AL muscle fibres on the central sternal plate, also on the ventral and posterior sternites, and a small portion on the ventral coxa. The expanded thoracic skeleton of Carcinus, when compared with the axial skeleton of Pagurus, has led to a reduction of the coxa, so that much more of the DEP muscle in Carcinus originates within the thorax than in Pagurus. All DEP muscle fibres attach to a broad tendon blade which inserts onto the ventral rim of the BI. On either side of the broad

insertion of the main DEP tendon are two small cuticle fragments onto which insert a few muscle fibres which originate on either side of the ventral coxa.

In basic structure, the PL muscle of Carcinus is similar to the PL muscle of Pagurus, with the origin of it's muscle fibres confined to the dorsal coxa, and inserting only onto the proximal face of a tendon hanging from the BI rim just posterior to the AL tendon head (Fig. 13a), but in Carcinus there is an addition to the PL muscle. A small fragment of cuticle is situated against the posterior edge of the main PL tendon onto which a few PL muscle fibres insert (Fig. 13a). This fragment has been described before (Wales et al., 1971, Moffett, 1975, McVean, 1975), but at that time it's significance was not appreciated since most investigators had concentrated their attentions upon the last walking leg, and in this limb the fragment is small (Fig. 13a). The subdivision of the PL muscle was first really noticed by the author while examining the BI muscles of a cheliped of the spider crab Maia squinado, where, as in Carcinus chelipeds (Fig. 13b), this part of the PL muscle is greatly enlarged and the cuticle fragment grown to encompass the "normal" PL tendon. The two parts of PL will henceforth be described as RPL for, in walking limbs, the main part of the muscle, and PPL for the new cuticle fragment and it's muscle fibres.

The subdivision of the PL muscle into PPL and RPL appears to be confined to brachyuran crabs. A number of

species have been examined and the division is present in each case, with the exception of the fifth pereopods of the true swimming crabs of the genus Macropipus (Portunus) which are modified for swimming. In the anomuran Pagurus and the macruran Homarus, the PL muscle is a single entity corresponding to the RPL of the Brachyura.

The subdivision of the PL muscle may account in part for some of the erroneous observations made by Wood & Wood (1932) who used Cancer and Maia as their type brachyurans, since in these species PPL is greatly expanded even in the walking legs.

Innervation of the BI musculature

The thoracic ganglion of Pagurus is situated in the anterior thorax and has the appearance in outline of several concertined ^a segmental ganglia, forming a link between the segmentally arranged ganglion chain of the more primitive macruran crustaceans and the condensed ganglion mass of brachyurans such as Carcinus. The sternal artery passes through the ganglion between the segment serving the third pair of pereopods and a fused group of ganglia serving the fourth and fifth pairs of pereopods and the first abdominal segment which has migrated forwards to join the thoracic ganglion (Jackson, 1913). Nerves supplying the third left pereopod leave their ganglion segment posteriorly to run past the sternal artery and

back along the thorax before turning outwards to the limb.

The nerve trunk containing the motor neurones serving the AL muscle leaves the ganglion and enters the limb dorsally, where it divides into two branches. The proximal branch of this nerve trunk passes ventrally into the coxa dividing into three further branches which all pass into the AL muscle (Fig. 12b). The distal branch remains dorsal in the limb to run peripherally between the coxal promotor muscle and the dorsal edge of AL, ending in the dorsal coxa by serving the coxa-BI chordotonal organ (CB) which stretches from the dorsal coxa to insert on the dorsal rim of the BI between the two levator muscle tendons (Fig. 12b).

The nerve trunk containing DEP motor neurones also leaves the thoracic ganglion independently of other bundles and enters 3LP to pass ventrally, before entering the DEP muscle the bundle branches. The larger proximal branch enters DEP muscle, the smaller branch runs peripherally between the AL and DEP muscles, loops under the ventral margin of the AL muscle and supplies the PL muscle (Fig. 12b).

The two largest nerve trunks which leave the thoracic ganglion segment serving 3LP supply the limb peripheral to the BI. These pass through the coxa and just before penetrating the membrane which seals the retained BI stump after autotomy, a small branch is given off the smaller of the two trunks to serve the sensory strand of CSD_1 (Fig. 12b).

Nerve bundles serving the fifth pereopod of Carcinus enter the skeletal box dorsally. The main nerve trunks run through the thorax and coxa into the peripheral limb, one nerve trunk sending a short branch to CSD₁ before passing through the autotomy membrane. The nerve supplying the posterior and larger part of the AL muscle runs into the muscle soon after entering the segment, and was the bundle recorded to represent AL motor neurone activity in this study. This nerve was also recorded from by McVean (1974). Hoyle & Burrows (1973) examined the fifth pereopod of the swimming crab Portunus sanguinolentus and found that the anterior and posterior branches of the AL muscle in that species are functionally and neurally separated as a specialisation for the swimming rather than walking function of that limb. McVean (1974) and Moffett (1975) for Carcinus and Cardisoma respectively, regarded the two main branches of the AL muscle in these species as making up a single functional unit with common innervation and in this study the nerve which supplies the anterior branch of the AL muscle was not monitored.

The DEP nerve enters the segment dorsally with the other bundles, and runs ventrally between the AL and DEP muscles before entering the DEP muscle. Unlike Pagurus, motor neurones serving the PL muscle of Carcinus do not share the DEP nerve trunk, but share, initially at least, the bundle supplying the coxal remotor muscles, which runs

along the ventral surface of the AL muscle, where a thin nerve branches off to run peripherally to the PL muscle.

Intracellular staining of BI motor neurones of Pagurus 3LP

The technique of retrograde axonal iontophoresis of cobalt chloride was utilised to examine the central projections of neurones serving the BI musculature of 3LP in Pagurus. In this technique the central projections of axons are filled with cobalt chloride, which is then deposited as a black precipitate by immersing the tissue in a weak ammonium sulphide solution. The projections are then revealed as black ramifications against the clear background of the remaining tissue. They can be examined in whole mount, or by reconstruction from serial sections where the profiles can be intensified by Timm's sulphide-silver treatment (Tyrer & Bell, 1974).

Motor neurones serving the AL muscle enter the ganglion segment from the posterior among the dorsal nerve roots. Peripherally, filled axons have diameters of 15-35 μm . Between entering the ganglion and passing into the neuropilar region, all except two axons are abruptly reduced in diameter, from 15-35 μm down to 1-3 μm in diameter. They remain "thin" for a length of 200-300 μm while arching dorsally to enter the dorso-lateral region of the neuropile, where just as abruptly, they regain most of their peripheral size, 10-25 μm (Fig. 14a). The

Fig. 14 : Photomicrographs of the segment of the thoracic ganglion of Pagurus bernhardus which supplies the third left pereopod. The motor neurones serving the anterior levator muscle have been revealed by axonal iontophoresis of cobalt chloride. Scale lines represent 100 μ m.

a. Lateral view of the left side of the ganglion showing the main somata group of AL motor neurones on the anterior margin of the segment. The major projections of these motor neurones run dorsally, and finer projections run ventrally into the neuropile.

b. Dorsal view of the left side of the ganglion segment serving 3LP in a different preparation. The main somata group are situated anteriorly while the major projections of AL motor neurones run laterally, sending fine branches medially and ventrally into the neuropile.

a.



b.

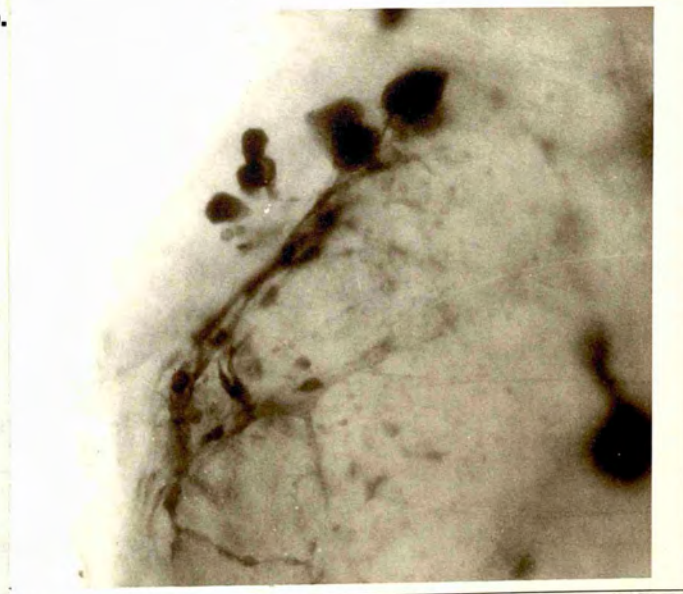

larger neuropilar projections then run anteriorly as a fairly closely defined bundle in the dorso-lateral neuropile, giving off finer branches ventrally and medially into the neuropile (Fig. 14a,b). The number of neurone somata filled in each preparation varies from 7-13, but their positions remained fairly constant. The main group of 8-13 cells, is situated on the antero-lateral margin of the ganglion segment (Fig. 14a,b), soma diameters range from 30-40 μm . The group is often made up by two sub-clusters of soma, one situated slightly dorsally from the more lateral cluster (Fig. 14a). Neurites serving these soma arise from the main tract in the dorso-lateral neuropile, they run around the lateral edge of the neuropile before turning outwards to their respective soma (Fig. 14b).

Two other neurones regularly fill from the AL peripheral nerve (not figured). The somata of these neurones are situated lateral to the main neuropile and tend to be slightly smaller, 20-30 μm diameter, than soma of the main anterior group. The peripheral axons of these two neurones are not abruptly reduced in diameter when they enter the ganglion, passing directly into the neuropile rather than following the "thinned" axons that arch dorsally. In the neuropile, when viewed from the dorsal surface of the ganglion, these two axons run diagonally towards the ganglion midline for a short distance before turning abruptly outwards to the lateral margin of the neuropile. On reaching the lateral edge of

the ganglion both axons give off short, thin neurites to their soma, the main projections then turn anteriorally and run around the lateral and anterior rim of the neuropile. Both axons end, close to the dorsal surface of the ganglion in distinct "claw-like" structures, with thick terminals, 10-15 μm in diameter, giving off short, 5-10 μm in length, fine, 1 μm and less in diameter, branches.

One remaining cell also occasionally fills from the AL nerve, it's peripheral axon and neuropilar projections follow those of the main antero-lateral somata group, but the neurone soma is situated posterior and ventral in the ganglion segment, on the anterior margin of the sternal artery gap. The neurite for this neurone projects with others of the main group, into the antero-lateral neuropile, but in this case, runs posteriorally and ventrally across the neuropile to it's small, 20 μm diameter, soma.

Motor neurones serving the DEP muscle enter the third pereopod segment of the thoracic ganglion in the dorsal bundle of nerve roots. Unlike some AL motor neurones, all of the DEP motor neurones filled have shown the region of reduced diameter between entering the ganglion and reaching the neuropile. The peripheral axons have diameters of 15-20 μm which are abruptly reduced to 3 μm and less. In some preparations this reduction is so severe that filled axons may not actually be visible in this region,

Fig. 15 : Photomicrographs of the central projections of motor neurones serving the DEP muscle of 3LP in Pagurus bernhardus which have been revealed by axonal iontophoresis of cobalt chloride.

a. Lateral view of the left side of the ganglion which shows the peripheral nerve trunk to the right of the photograph and the "thinning" region (T) of the motor axons before they enter the neuropile. The major projections of these motor neurones pass ventrally into the neuropile.

b. Dorsal view of the left side of the ganglion segment serving 3LP, from the same preparation as a. The main group of DEP motor neurones are situated on the anterior margin of the sternal artery gap, and the major projections run diagonally across the hemi-segment. Two motor neurone somata are situated eccentric^aly on the lateral margin of the ganglion.

c. Lateral view of the left side of the ganglion showing DEP motor axons as they abruptly reduce in diameter on entering the ganglion.

St.Art., sternal artery gap; T, thinning region of motor axons between reaching the ganglion and passing into the neuropile.

Scale lines represent 100 μ m.

a.

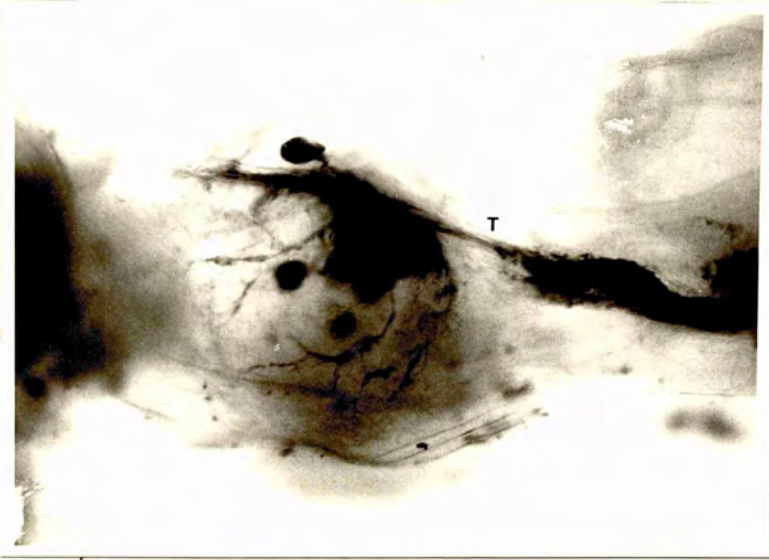

b.



c.



only the thicker peripheral portions in the nerve root and central regions in the neuropile are discernable. The main bundle of filled projections runs diagonally across the neuropile, ending close to the dorsal surface in "claw-like" structures similar to those described above for the two non-thinning AL motor neurones. Fine branches pass ventrally into the neuropile from the main track as it passes anteriorly (Fig. 15a), and approximately a third way across the segment, neurites are given off which run posteriorly and slightly ventrally to the main somata group (Fig. 15b). The number of somata filled varies from 5-9, and range in diameter from 50-80 μm , they are situated medially in the segment on the anterior margin of the sternal artery gap (Fig. 15b). Two other neurones fill from the DEP nerve, their somata are found on the lateral margin of the ganglion, while their neuropilar projections follow those of the main group (Fig. 15a,b).

In this investigation, most of the motor neurones revealed by backfilling with cobalt chloride have shown a distinct and abrupt reduction in diameter between entering the ganglion segment and reaching the neuropilar region. The thinning region occurs over a distance of 200-300 μm where the diameters of motor axons are reduced from 10-35 μm , down to 3 μm and less (Fig. 15c), re-expanding to the greater proportion of their peripheral size when

they reach the neuropile. This reduction is distinctly different to any gradual tapering of axons entering the central nervous system as described by Sandeman (1969). The ganglion surface shows no constriction in this area, and conventional histological sections reveal no intraganglionic structure or ^s ~~constriction~~ ^{restricted} for the axons to negotiate. The phenomenon is not ~~resisted~~ to these results, thinning of motor axons has also been observed by the author in units serving Pagurus and Carcinus chelae, and by Pilkington (personal communication) in the scaphognathite (baler) levator and depressor motor neurones of Carcinus. Not all motor axons thin. For instance neither of the two laterally situated soma serving the AL muscle thin and sensory fibres revealed by cobalt backfilling only taper as they enter the ganglion.

The somata of invertebrate sensory neurones are usually situated peripherally to the central nervous system. Those of the coxa-BI chordotonal organ (CB) are attached to an elastic strand stretched between the dorsal coxa and dorsal rim of the BI (Alexandrowicz & Whitear, 1957, Whitear, 1962). The nerve root containing the centripetal axons from CB also contains AL motor neurones (Fig. 12b) and CB sensory fibres enter the ganglion with them in this nerve root. Peripherally, filled CB sensory axons range from 3-10 μm in diameter. When they enter the ganglion these axons do not "thin", but gradually taper as they progress centrally. The central projections of

Fig. 16 : Central projections of sensory fibres from the coxa-BI chordotonal organ of the third left pereopod of Pagurus bernhardus revealed by backfilling with cobalt chloride. Scale lines represent 100 μ m.

a. Dorsal view of the left half of the ganglion segment serving 3LP. The major tract of filled CB sensory fibres runs across the ganglion, bifurcating as it approaches the ganglion midline.

b. Lateral view of the same preparation as a. The major tract of CB sensory fibres runs along the lateral edge of the neuropile before it turns inwards and out of the focal plane of this photograph (X). Before the major tract passes into the neuropile it gives off a number of fine branches (f).

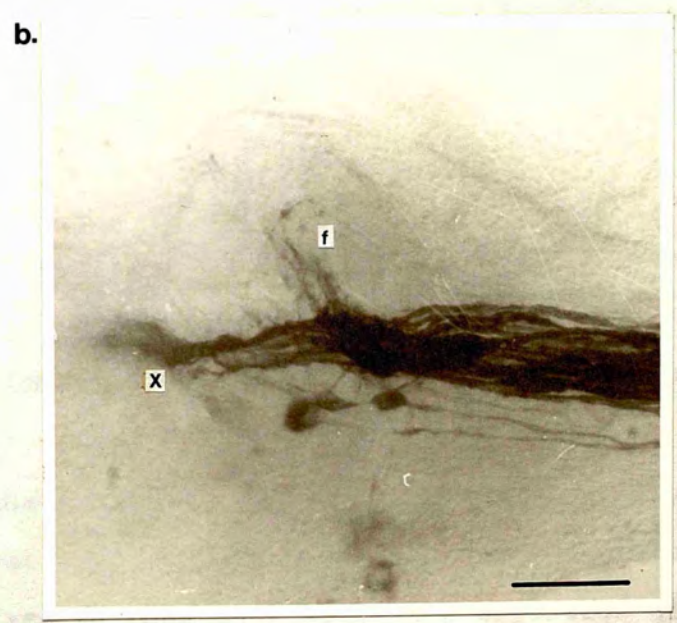
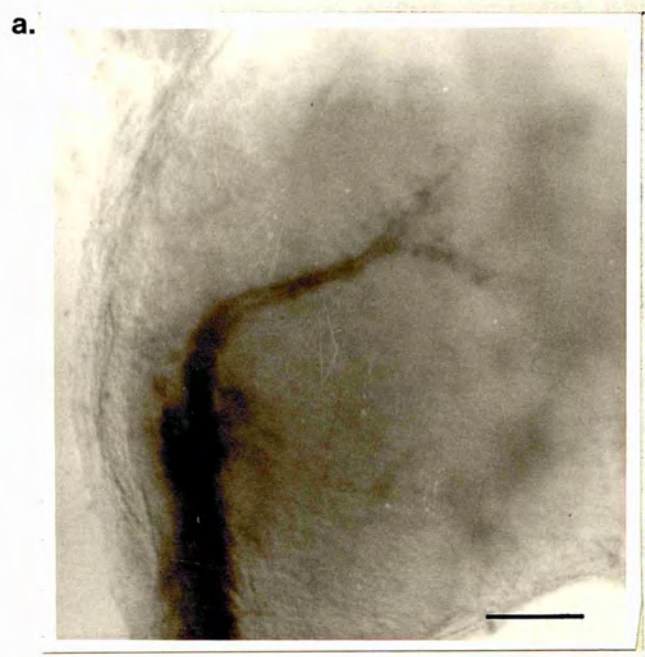

these sensory axons form a tight bundle of fibres, unlike the looser branching shown by motor neurone projections, and pass laterally around the neuropile for some distance before turning inwards (Fig. 16a). The bundle then runs towards the ganglion midline through the neuropile, bifurcating into two tracts approximately two thirds of the way across their ipsilateral hemisegment, to terminate as very fine fibres of less than 1 μ m diameter, towards the anterior medial edge of the ipsilateral neuropile (Fig. 16a). Before the main bundle of fibres pass into the neuropile from the lateral edge of the ganglion, a group of fine fibres are given off which run dorsally and medially into the neuropile for up to 200 μ m (Fig. 16b). These are branches of sensory axons which continue on into the neuropile within the main bundle and do not represent the termination of individual axons.

Attempts were made to fill the central projections of motor neurones serving the PL muscle and sensory axons from CSD₁, but none were successful. Each share nerve trunks with other units, (DEP for PL and peripheral limb for CSD₁) for a considerable distance from the ganglion. The incubation times (see Appendix 1) necessary to allow the migration of cobalt from such peripheral nerves to the CNS are so long that autolytic digestion always disrupted the intraganglionic structure.

Structure of the BI and effects of levator tendon interactions

The following description of the structure of the BI and especially the region distal to the levator tendon insertions applies equally to Pagurus and Carcinus. In both animals the structure is essentially similar.

In most reptantian decapod crustaceans the joint between the basipodite and ischiopodite limb segments is absent and the segments fuse to form the basi-ischiopodite (BI). In the BI a line completely encircles the limb which marks the preformed breakage plane which separates at autotomy (Figs. 12, 13). Immediately distal to the insertion of the AL muscle, the breakage plane is deflected distally. This deflection marks the only intact cuticular connection across the breakage plane, and autotomy is initiated when this cuticle is fractured and the peg withdrawn (McVean, 1973, Moffett, 1975).

The surface of the BI between the insertions of the levator muscles and the breakage plane is marked by a number of externally visible lines (Figs. 12a, 13a,b), some outline areas of cuticular thickening, others penetrate right through the limb cuticle. The plug in the breakage plane is the distal point of an area of cuticle marked out by such lines, an approximately triangular area with a broad base on the rim of the BI and the plug in the breakage plane as the apex (Figs. 12a, 13a,b, 17a). The posterior margin of this triangle is marked by a furrow which runs back from the plug to the

rim of the BI between the insertions of the two levator muscles, this furrow was originally described by Paul (1915), who used it as the basis of his hypothesis for the mechanism of autotomy. The anterior margin of the triangle is more complex. Proximally, a furrow in the rim of the BI divides the insertion of the AL tendon head, which in Carcinus continues on into the tendon head itself (Fig. 13a). This furrow runs distally in the BI for a short distance before turning and running anteriorly around the BI (Figs. 12a, 13a,b). The area of cuticle enclosed by this line bears the ventral projection of the BI which closely abuts against a matching face on the AL tendon head (Figs. 17, 18, Moffett, 1975). Distal to this area of cuticle is the soft membrane which forms the only externally visible portion of the CSD₁ sense organ, the posterior margin of which makes up the rest of the anterior edge of the cuticle plug triangle (Fig. 17).

The insertion of the AL tendon head is therefore divided, anteriorly, onto the block of cuticle which runs anteriorly around the BI and posteriorly, onto the triangular block of cuticle which culminates distally as the plug in the breakage plane. The PL and RPL tendons insert onto the BI posterior to Paul's furrow (Figs. 12a, 13a,b).

The dorsal BI has a complex structure when compared with other limb segments, so autotomy occurs quickly and

cleanly, and limb regeneration may proceed efficiently (Needham, 1953). Yet for the greater part of the crab's life it may not use this system, therefore the normal activities of the limb must not be allowed to endanger the integrity of the breakage plane. Early attempts to understand autotomy were mainly confined to describing the anatomy of the BI and its muscles, and then attempting to interpret the mechanics of the system (McVean, 1975). Thus Fredericq (1883) showed that for autotomy to occur, the AL muscle must contract isometrically against the dorsal rim of the BI, and this observation coloured most of the following studies on the problem. When combined with the observation that every muscle in the limb, except the AL muscle, may be severed from its insertion and autotomy will still occur (Wood & Wood, 1932), it gave rise to the general assumption that the only difference between locomotion and autotomy was the degree of force delivered by the AL muscle onto the dorsal BI.

Although Paul (1915) had indicated that both levator muscles may be stimulated by injury, it was left to McVean (1973) to show that autotomy was not just a matter of increased force delivered by the AL muscle onto the BI, he was also the first to accurately describe the unusual PL muscle and tendon (McVean, 1970), which leads us to make a critical study of the effects the BI levator muscles have upon each other and of the way they might act on the dorsal BI to differentiate autotomy from normal locomotion.

The first point is that during normal locomotion, contraction of the AL muscle would not be isometric, ^{since} the BI and peripheral limb are free to move about the coxa-BI joint. Limb levation results from the contraction and shortening of AL muscle fibres, so that little force would actually be imposed onto the BI. Should movement of the limb be prevented, attempted limb levation would result in the contraction of the AL muscle approaching an isometric state. Since most crustaceans require at least a degree of injury to the peripheral limb before autotomy can occur, the force developed by the locomotor command to the AL muscle, even when exerted isometrically is therefore probably insufficient to produce autotomy, unless, as suggested by Clarac & Wales (1970) a positive feedback loop operated from the strain exerted onto the BI back to the AL muscle, building up AL force to a level which could produce fracture.

In some species, where the BI cuticle is very thin, as in Porcellana platycheles (Hoadley, 1934) and Galathea squamifera (Wood & Wood, 1932), autotomy does occur upon very slight stimulation and it is possible that the switch from isotonic to isometric contraction of the AL muscle, or even a sudden exertion of force by the AL muscle, is sufficient to cause autotomy in these species.

In most crustaceans, however, injury is necessary to elicit autotomy, when excited by the CNS command stimulated by injury extra force could be exerted by the

AL muscle (McVean, 1974). McVean (1973), however, showed that this force can be less than the force produced by that muscle upon other occasions when autotomy does not result. Thus although the AL muscle is the source of the force that causes fracture and withdrawal of the plug by itself it is not usually sufficient.

Wood & Wood (1932) suggested that the AL muscle was reserved for autotomy and the PL muscle used to raise the limb during locomotion, *but ablating the AL muscle does interfere considerably with limb levation.* ~~but repeating their ablation of the AL muscle, did interfere considerably with walking in that limb,~~ While ablation of the PL muscle not only did not appear to impede locomotion, but also did not prevent autotomy. Therefore we are not dealing with a mechanically simple system. It is not just a matter of one alternative versus another. The AL muscle can provide the force necessary to cause autotomy on it's own, as well as normally levate the limb without causing autotomy.

Another factor is the posterior levator muscle. This muscle and it's tendon are unusual. If for the moment, we disregard the PPL muscle in Carcinus and deal only with the PL muscle of Pagurus (Fig. 12a) and RPL muscle of Carcinus (Fig. 13a,b), when the tendon blade is pulled in the direction normally taken by it's muscle fibres, it not only rotates dorsally about it's own insertion onto the rim of the BI, but also, because of it's close apposition with AL, influences the position of the AL tendon head (Figs. 17b, 18) (McVean, 1973, Moffett, 1975).

Fig. 17 : A diagrammatic representation of the dorsal rim of the BI of Pagurus bernhardus showing the cuticular structure, the BI levator muscle tendons and their interactions. The peripheral limb is to the left of the figure, the coxa and thorax to the right.

a. When the PL muscle is inactive it's tendon blade projects perpendicularly from the dorsal rim of the BI. The AL tendon head is held flush with the BI and the abutting faces (f) between the tendon head and the BI are closed.

b. When PL muscle fibres contract (small arrow), the PL tendon rotates about it's dorsal attachment to the BI. The close apposition of the PL tendon with the AL tendon head means that rotation of the PL tendon also causes rotation of the AL tendon head about it's attachment to the BI, separating the faces between the BI and tendon head.

Legend as Figs. 12 & 13.

This diagrammatic representation is based upon the walking leg of Pagurus, but is also applicable to Carcinus where the structure of the BI and the effects of RPL tendon rotation on the AL tendon head are similar.

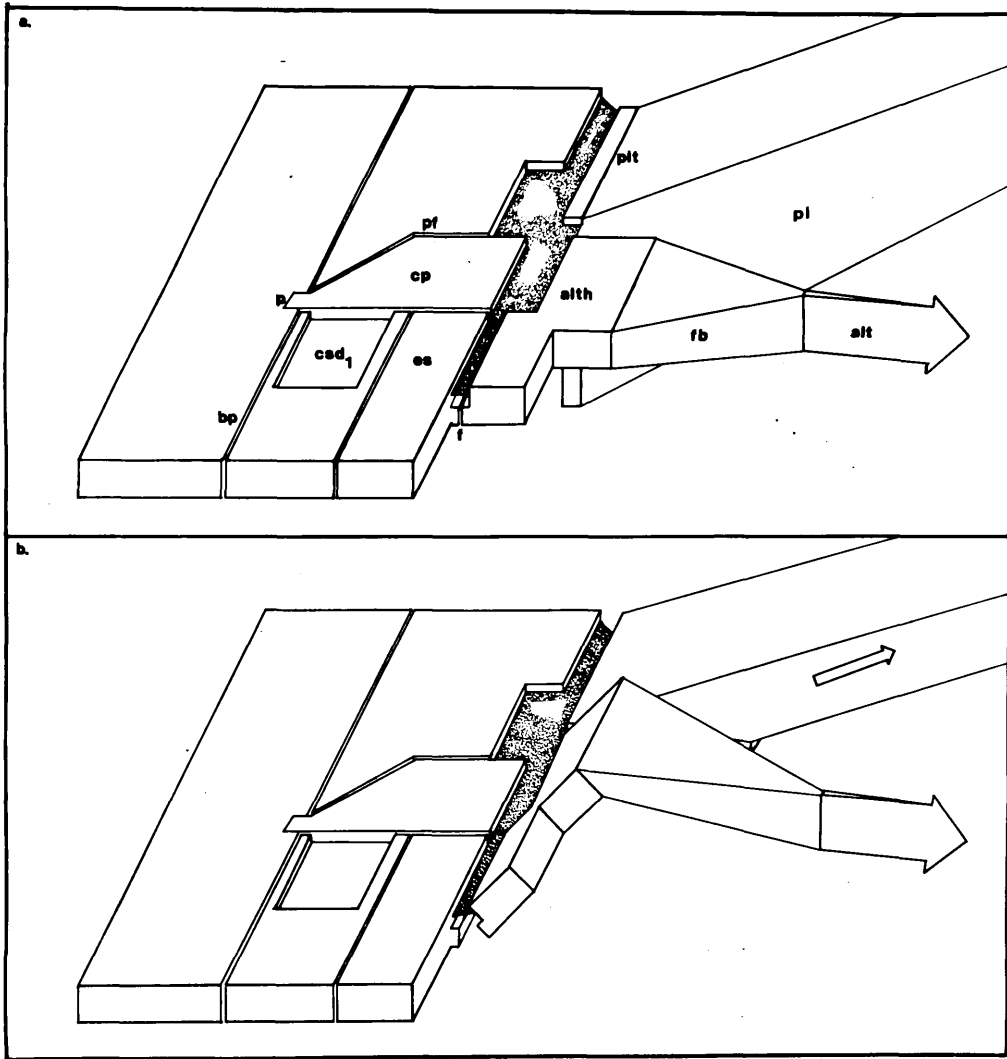
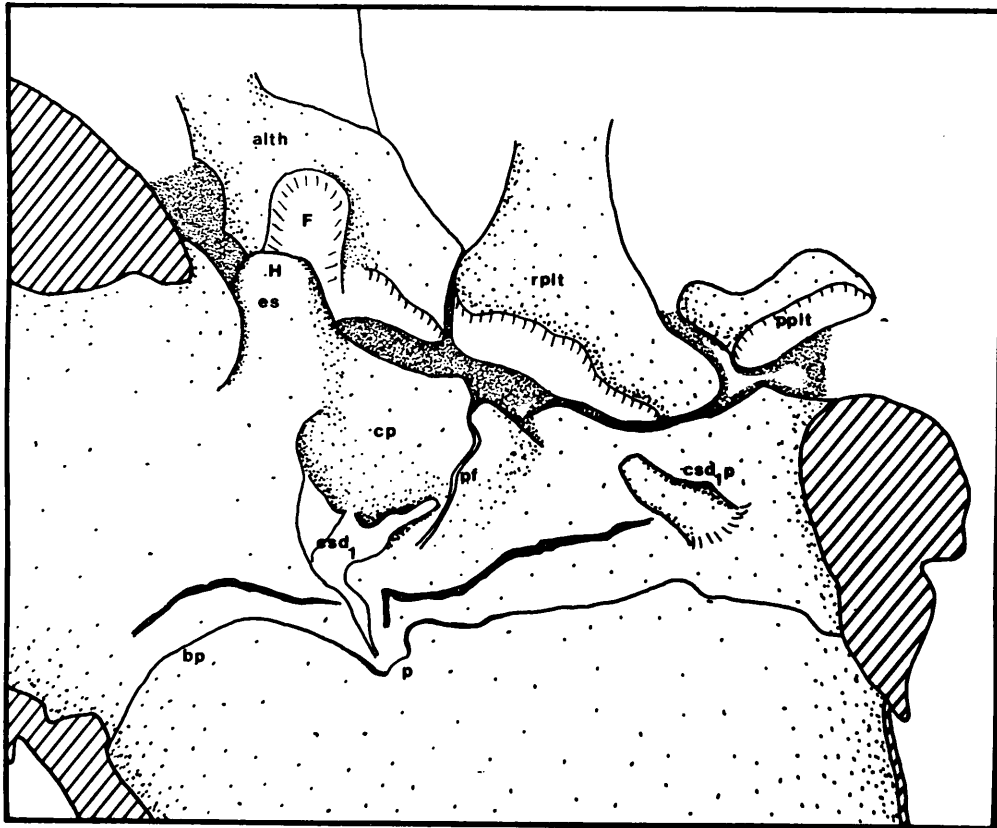

Fig. 18 : The internal cuticular structure of the BI and levator tendons of the third right pereopod of Carcinus maenas (x 15), revealed by removing all soft tissues by alternate freeze-thawing. The RPL tendon is held in the rotated position so that the AL tendon head is rotated and the abutting faces between the tendon head and the BI are separated (F-H).

csd_{1p}, the cuticle peg to which is attached one end of the CSD₁ sensory strand, the other end inserts onto the soft membrane (labelled csd₁) distal to the insertion of the AL muscle.

Other legend as for Figs. 12 & 13.



When the PL muscle is inactive, the AL tendon head inserts flush with the BI and the faces between the ventral tendon head and the BI are forced together (Fig. 17a). When the AL muscle contracts, these faces are held together for most of the arc of the BI about the coxa-BI joint. They are, however, opened at extreme elevation since the orientation of AL muscle fibres pulls them apart once the BI is raised beyond a point well short of full levation (McVean, unpublished observation). When the PL tendon rotates, the abutting faces are separated by the rotation of the AL tendon head around its insertion onto the dorsal rim of the BI (Figs. 17b, 18). This is possible since there is a flexible band between the AL tendon head and tendon blade (Figs. 12a, 13a,b, 17). Thus the slight dorsal movement of the tendon head does not unduly affect the orientation of the tendon blade, and the five-fold mechanical advantage of the PL muscle (McVean, 1973) should be sufficient to hold the AL tendon head in the rotated position during contractions of the AL muscle.

Therefore we have two alternative orientations for the AL tendon head and thus presumably two alternative deployments for the force exerted by the AL muscle. We know that to cause cuticular fracture and thus autotomy, AL force must be concentrated onto the cuticular plug, while during locomotion or in situations where the breakage plane might be accidentally threatened, AL force must be directed away from the plug.

Therefore, either

1. When the PL muscle is inactive, the faces between AL tendon head and the BI are forced together and AL force is then concentrated onto the plug, but when the PL tendon rotates to separate the abutting faces, AL force is instead spread around the BI.

or 2. AL force is concentrated onto the plug when PL tendon rotation separates the faces, and is spread when the PL muscle is inactive and force directed through the abutting faces into the BI.

Although the anatomy of the dorsal BI and the interactions of the levator tendons do give some indication of the probable mechanical events (Fig. 17), the choice between these two alternatives must depend upon how the muscles themselves react in the appropriate circumstances, so that the complex mechanics of this region can be interpreted in terms of physiological evidence rather than anatomically based hypotheses.

II. THE MECHANISM OF AUTOTOMY

To be able to interpret the reactions of the BI muscles during autotomy and locomotion it is first necessary to investigate some of the basic physiological features of the system. In this investigation, attention is focused upon the physiology of the PL muscles and the

role of CSD₁. The AL muscle is not treated in any depth, since although providing the force for both autotomy and locomotion, the physiology of the AL muscle in these circumstances has been described in detail by McVean (1974) and Moffett (1975). The main point, repeated here, is that injury to the peripheral limb results in high frequency firing of AL motor neurones and high tension development in its muscle fibres (McVean, 1974, Moffett, 1975).

Sensory reflex responses in BI motor neurones

The coxa-BI chordotonal organ (CB) spans the dorsal coxa-BI articulation, and is sensitive to the direction and speed of movement, as well as position, of the BI relative to the coxa (Bush, 1965a). The CB organ stimulates resistance reflex responses in the BI levator and depressor muscles (Bush, 1965b) so that passive movement of the limb in one direction is opposed by the reflex excitation of antagonistic motor neurones. Thus in Carcinus, when the CB organ strand is alternately stretched and relaxed by the passive depression and then levation of the BI and peripheral limb about the coxa-BI joint, alternate bursts of firing occur in motor neurones serving the AL and DEP muscles (Fig. 19a). Depression of the limb results in synergistic bursts of impulses in motor neurones serving both AL and PL muscles (Fig. 19b,c). In Carcinus and Pagurus two or three AL units and one PL unit respond to

Fig. 19 : Resistance reflex responses in BI motor neurones when the sensory strand of the coxa-BI chordotonal organ is stretched and released.

a. Alternate bursts of impulses can be seen in the AL and DEP nerves of Carcinus when the CB strand is respectively stretched and relaxed by passive depression and levation of the limb about the coxa-BI joint.

b. Synchronous bursts of impulses in the AL and PL nerves of Carcinus seen when the CB strand is stretched by passive limb depression. Several units serve AL, while a single unit responds in PL.

c. Responses of Pagurus levator units when the CB strand is stretched, as in b. only a single PL unit responds.

Solid bars indicate stretching, and dots indicate relaxation of the CB strand.

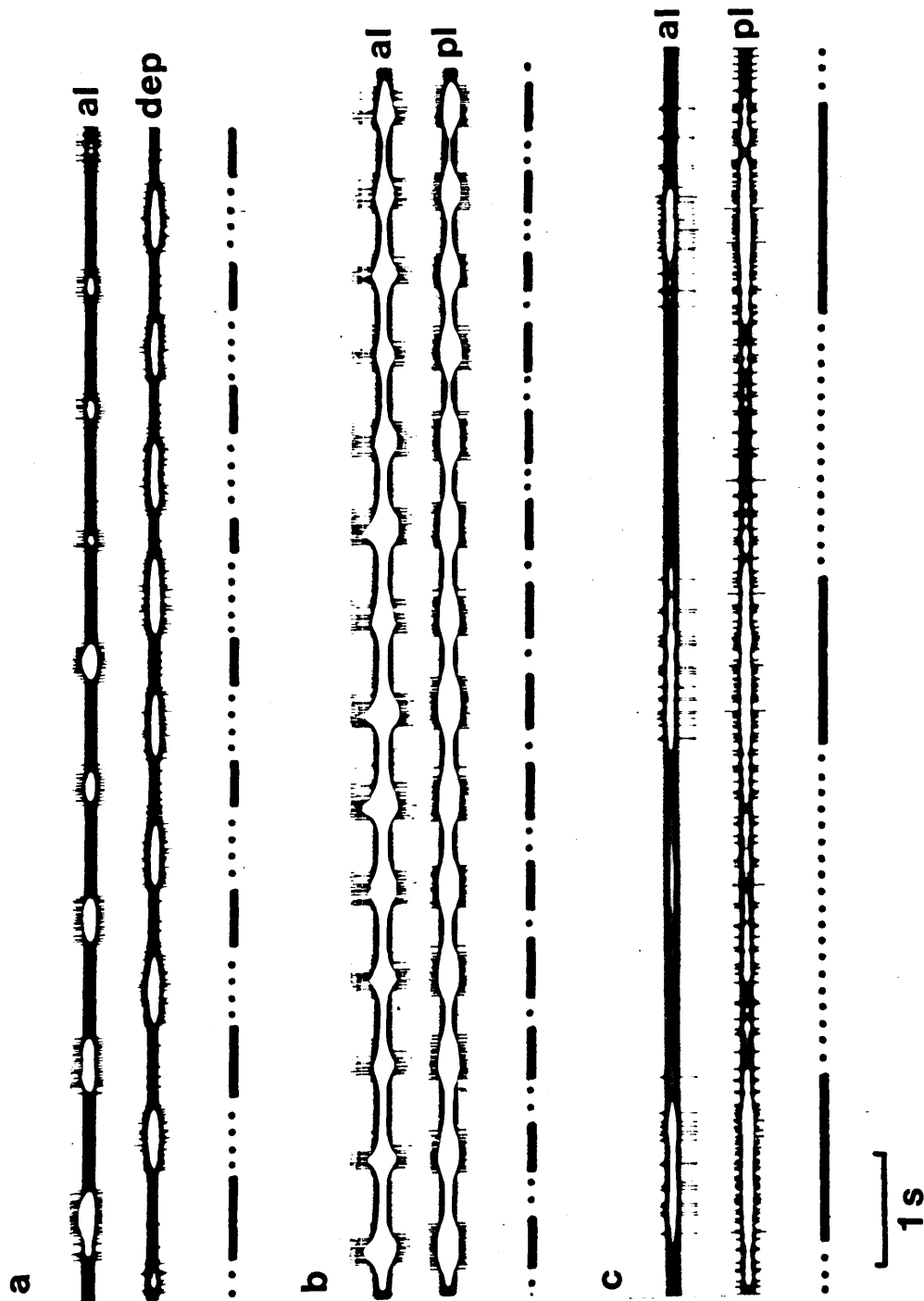
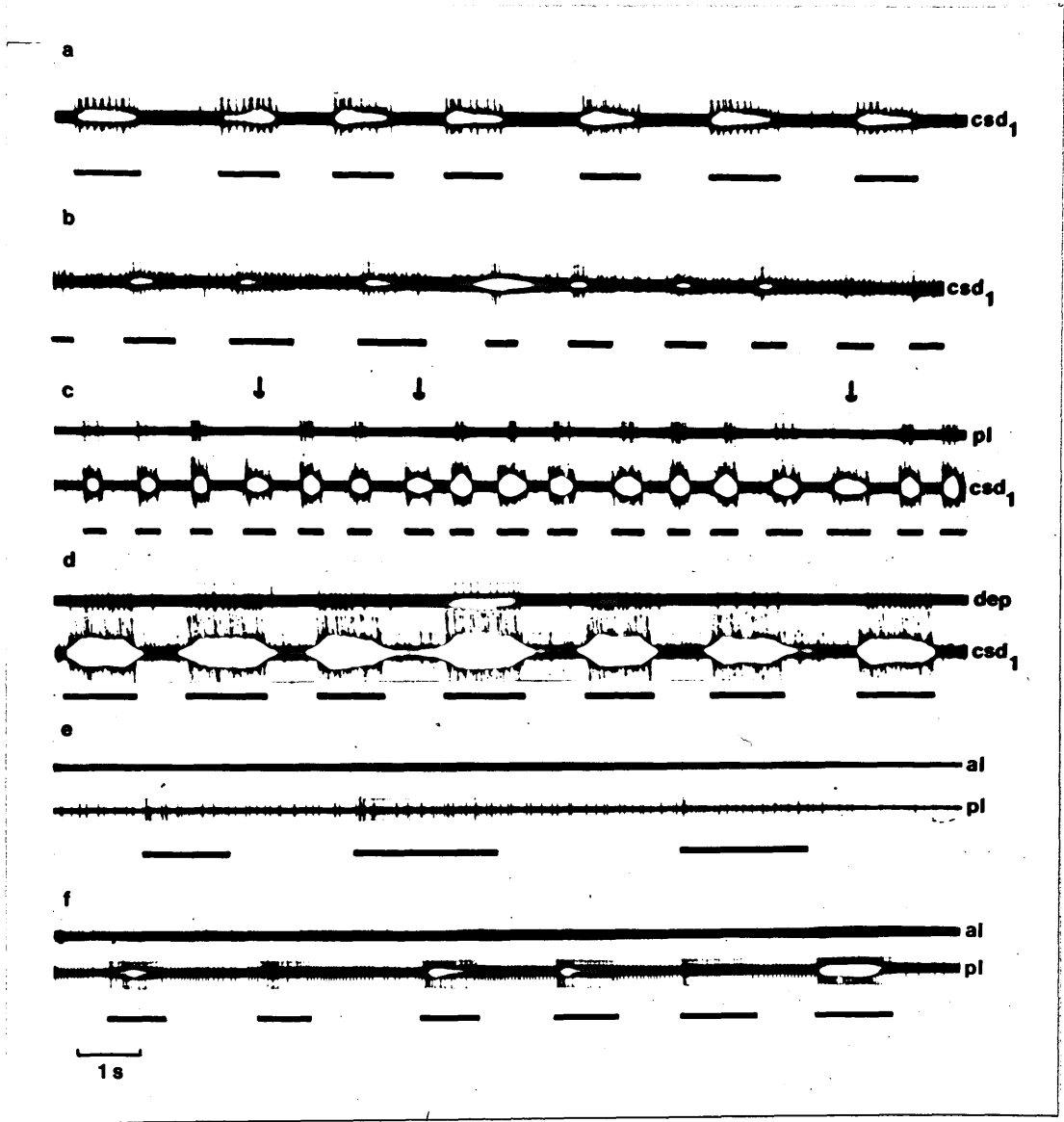

Fig. 20 : Responses of the CSD₁ sense organ and it's reflex connections with motor neurones serving the BI muscles.

- a. When the soft membrane overlying CSD₁ in Carcinus is distorted with a fine probe, sensory units fire in the CSD₁ afferent nerve.
- b. When isometric tension is applied to the AL tendon of Carcinus, it also elicits firing in the CSD₁ afferent nerve.
- c. In Pagurus, not only does distorting the CSD₁ membrane elicit firing in the CSD₁ nerve, but it also stimulates a reflex response from a motor unit serving PL. Note that on several occasions (arrowed) distortion stimulates CSD₁, but not the PL unit.
- d. In Pagurus, distorting the CSD₁ membrane elicits firing in a unit serving the BI depressor muscle.
- e. In this record of the two levator nerves of Pagurus, a small unit serving PL is firing tonically and when CSD₁ is stimulated with a fine probe a new larger unit is reflexly excited. No unit in AL responds to the distortion of the CSD₁ membrane.
- f. In Carcinus, mere distortion of the CSD₁ membrane is insufficient to excite reflex responses from the BI levator motor neurones. In this species, considerable isometric tension has to be applied by the AL muscle onto the BI before the reflex firing of the large PL unit is stimulated. As in Pagurus (e.), AL shows no response to this stimulation of CSD₁.

Bars indicate stimulation of CSD₁.



resistance reflex excitation (Fig. 19b,c). In Pagurus, this PL unit usually fires at a low tonic level, which is increased when CB is stretched (Fig. 19c).

Pressure applied with a blunt probe to the soft membrane which forms the only externally visible portion of CSD_1 , elicits firing in CSD_1 sensory units (Fig. 20a, c,d; Clarac et al., 1971; Moffett, 1975). A more natural form of stimulation for CSD_1 is strain imposed upon the dorsal rim of the BI by contraction of the AL muscle (Clarac et al., 1971), and if the AL tendon is pulled in the direction in which the AL muscle normally contracts, CSD_1 units are excited (Fig. 20b; Clarac et al., 1971; Moffett, 1975). Three categories of sensory units can be seen responding to such a stimulus. The largest units respond phasically at the onset of tension application, while intermediate sized and small units respond tonically, maintaining an enhanced firing frequency for the duration of the stimulus (Fig. 20b).

In Pagurus, distortion of the CSD_1 membrane with a blunt probe will not only stimulate CSD_1 units, but ^{can} also reflexly excite a motor neurone serving the PL muscle (Fig. 20c). The tonically active PL motor neurone which responds to resistance reflex excitation (Fig. 19c) is usually inhibited (Fig. 20e). In Fig. 20c it can be seen that while pressure applied to the CSD_1 membrane can be sufficient to stimulate sensory units, these may fail to excite the reflex loop onto PL (arrowed). Careful

application of pressure to different areas of the soft membrane revealed that, in Pagurus, the reflex loop onto PL is only stimulated when pressure is applied to the posterior margin of the membrane adjacent to the cuticular plug, pressure applied elsewhere does not initiate the reflex although it does activate some CSD₁ sensory units. Clarac et al., (1971) have shown that when different areas of the CSD₁ membrane are stimulated, different sensory units respond. In Pagurus, as well as exciting a reflex loop onto PL, stimulation of CSD₁ also reflexly excites a motor neurone serving the DEP muscle (Fig. 20d).

In Carcinus, although CSD₁ sensory units are stimulated by pressure applied to the CSD₁ membrane (Fig. 20a), this form of stimulation will not excite the reflex loop onto PL motor neurones. For this to happen, considerable tension has to be applied to the AL tendon (Fig. 20f). The reflex loop from CSD₁ exciting a unit serving the DEP muscle in Pagurus (Fig. 20d), is not found in Carcinus. In both species, AL motor neurones show no response to either pressure applied to the CSD₁ membrane (Fig. 20e), or to tension applied to the AL tendon (Fig. 20f).

These are not the only reflex responses which can be elicited from BI motor neurones. Moody (1972) described "centripetal" reflexes in which movements of peripheral limb joints excited motor neurones concerned with the coxal promotor and remotor muscles in the crayfish.

Centripetal reflexes onto BI motor neurones can be found from limb joint receptors peripheral to the breakage plane. The most obvious responses from BI motor neurones can be elicited by passive movements of the merus-carpus, and propus-dactylus joints, both of which articulate in the same plane as the coxa-BI joint. Such movements activate, to a lesser extent, the same units which respond to resistance reflex excitation from the CB chordotonal organ. Since these responses are not involved in autotomy, nor in locomotion (Barnes et al., 1972) they were not studied in any more detail.

The posterior levator muscle and innervation

The previous section revealed that the PL muscles of Pagurus and Carcinus are innervated by two axons, one small unit which may be tonically active, responding to resistance reflex excitation (Fig. 19b,c), the other, larger unit reflexly excited by CSD₁ stimulation (Fig. 20e,f).

These two units have radically different effects upon the PL muscle. In both species, the main part of the PL muscle consists of the triangular tendon blade hanging from the dorsal rim of the BI, which rotates when its muscle fibres contract (Figs. 17, 18). When the smaller PL unit is stimulated by stretching the CB chordotonal organ strand, it has no influence upon the orientation of either the PL or RPL tendon blades (Figs. 21a; 22a),

but when the larger PL unit is stimulated, the tendon blades rotate (Figs. 21b, 22b).

In Pagurus, where the PL muscle consists entirely of muscle fibres inserting onto the single triangular tendon blade, it was thought that the PL innervation might be anatomically separated, so that the small unit supplies fibres situated in dorsal regions of the muscle where their contraction would have little influence upon the orientation of the tendon blade, while the large unit might preferentially innervate muscle fibres inserting onto the ventral tip of the tendon blade where their contraction would more easily influence the orientation of the tendon because their position has an increased mechanical advantage for rotation. This hypothesis was tested by recording intracellularly from muscle fibres situated dorsally, medially and ventrally within the PL muscle while stretching the CB strand to recruit the tonic unit, and stimulating CSD₁ to recruit the large unit.

Although crustacean motor units, made up of a motor axon and its muscle fibres, can show a considerable degree of variation in elicited electrical responses within the same unit (Atwood, 1973, Sherman, 1977), in this study the electrical responses recorded from individual muscle fibres, elicited by separate stimulation of the two PL neural units, were sufficiently distinct to allow them to be grouped into three categories based

Fig. 21 : The posterior levator muscle of Pagurus
bernhardus.

a. When resistance reflex responses are elicited from the small unit in the PL nerve (bars), the PL tendon blade does not rotate.

b. On the other hand, when the large unit in the PL nerve is stimulated by distortion of the soft membrane overlying CSD₁ (bars), the PL tendon blade does rotate.

mm, rotation of the PL tendon blade was monitored by placing the wand of a Geo. Washington strain gauge against the tip of the tendon. A DC response was obtained when the tendon blade rotated.

c. An intracellular record obtained from a PL muscle fibre which shows ejp's resulting from impulses in the small PL unit. These ejp's facilitate in response to the increased rate of firing of the small PL unit when CB is stretched (bars).

d. Large, fast ejp's are elicited from a PL muscle fibre when distortion of the CSD₁ membrane stimulates firing of the large unit in the PL nerve (Bars).

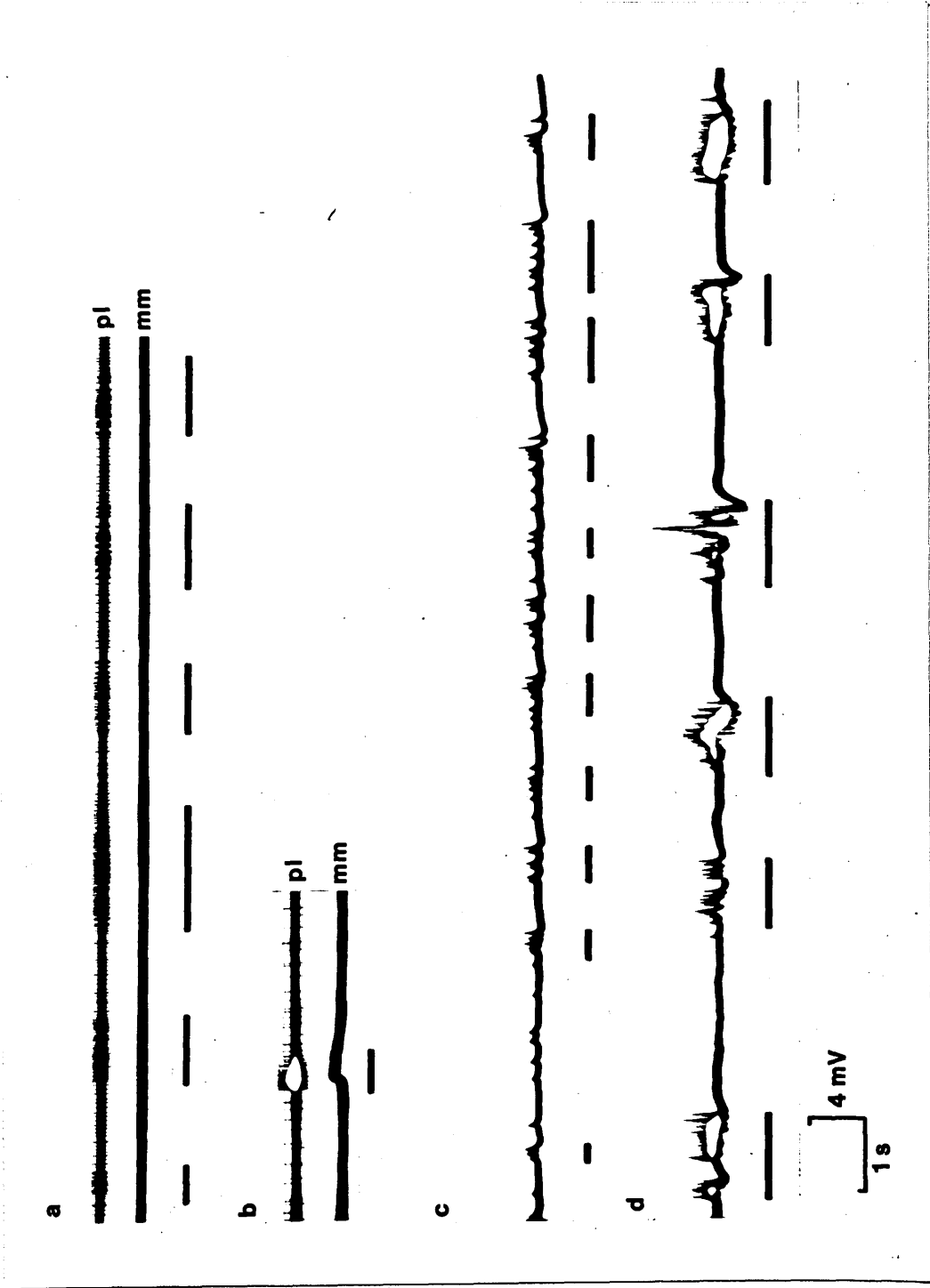

Fig. 22 : The RPL muscle in Carcinus maenas.

a. When the small PL unit is stimulated by stretching the CB strand (bars), it does not influence the position of the RPL tendon blade (mm, same as Fig. 21).

b. The RPL tendon blade does rotate when impulses in the large PL unit are stimulated when CSD_1 is stimulated by tension applied to the AL tendon (bars).

c-f. Intracellular records obtained from RPL muscle fibres.

c. This muscle fibre, situated ventrally in RPL, is only innervated by the fast PL unit (bars indicate stimulation of CSD_1).

d. This muscle fibre, found medially in RPL, is innervated by both PL units. The large, fast ejp's result when CSD_1 is stimulated by tension applied to AL tendon (bars). The small ejp's between the bursts of large ejp's result when tension being released from the AL tendon stretches the CB strand to stimulate resistance reflex responses in the small PL unit.

e. & f. Responses from a single, dorsally situated RPL muscle fibre to firing of the slow PL unit (e, bars) and stimulation of the large PL unit (f, bars).

Vertical scales : c, 4 mV, d, 8 mV, e & f, 20 mV.

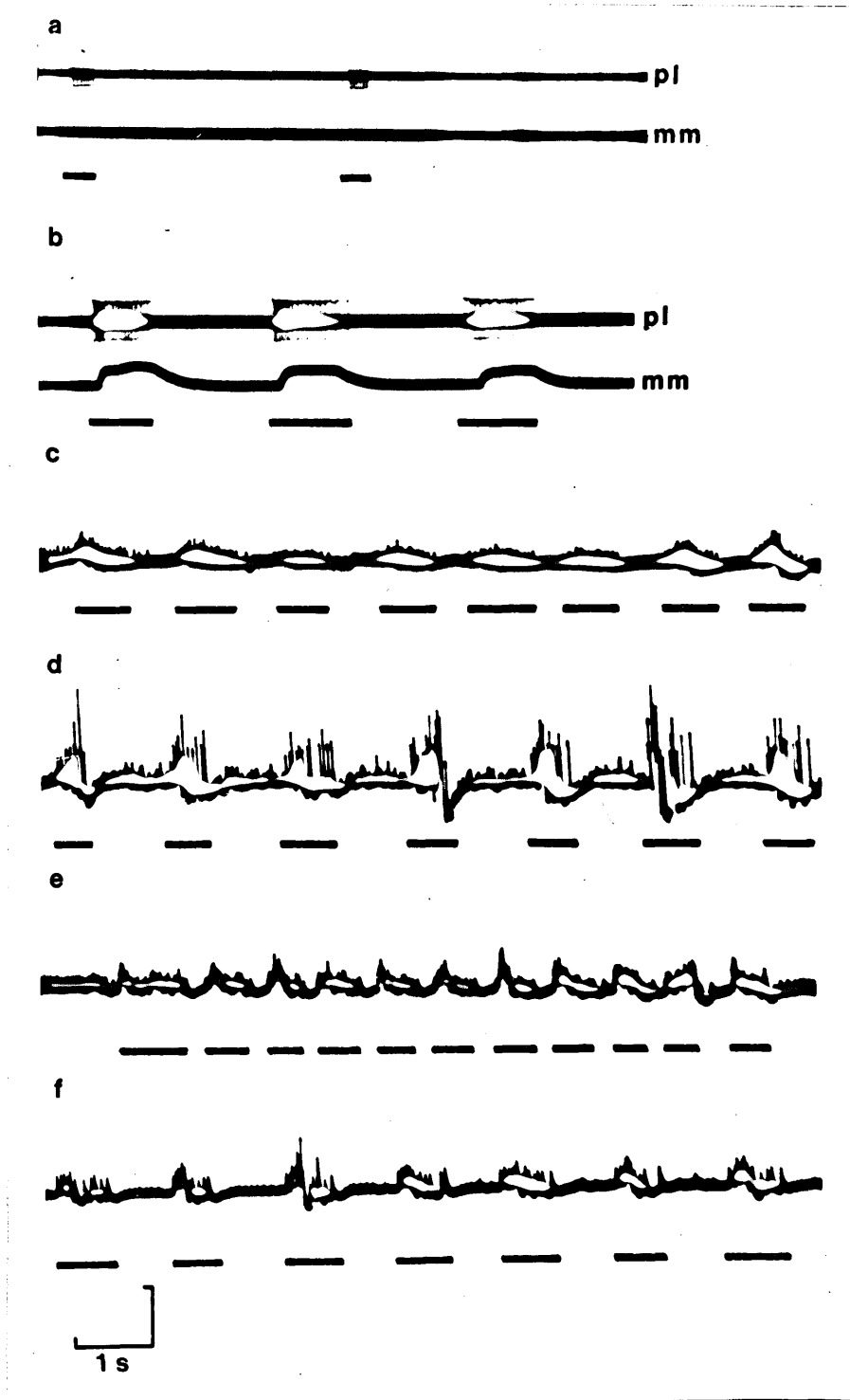

solely upon the innervation of each muscle fibre. These groups of muscle fibres in the PL muscle of Pagurus are, slow fibres innervated only by the small PL unit, intermediate fibres innervated by both PL units, and fast fibres innervated by only the large PL axon. The electrical responses of individual muscle fibres can be classified as slow when elicited by the small PL unit which stimulates small unitary ejp's showing considerable facilitation (Fig. 21c), and fast when elicited by the large PL unit (Fig. 21d).

However, the three categories of muscle fibres were found throughout the muscle. Similar experiments have also failed to reveal any anatomical segregation of electrophysiologically different types of muscle fibres in either lobster claw (Govind & Lang, 1974), or the claws of Cancer and Macropipus (Warner & Jones, 1976).

In Carcinus, where the PL muscle is separated into two parts (Fig. 13a,b), the innervation of the two PL units might also be expected to be separated so that the small unit served PPL, and the large unit supplied RPL. However, Fig. 23c,d shows that both axons are common to the two parts of the PL muscle. Therefore the hypothesis of an anatomical segregation of the two units within RPL, to account for the different effects they have upon RPL tendon blade (Fig. 22a,b), as had been suggested for the single PL of Pagurus, was examined in the same way for Carcinus RPL. The results are shown in Fig. 22 and Table 8.

Although the absolute size of ejp's varied from muscle fibre to muscle fibre, on the whole, the small PL unit of Carcinus evoked small ejp's in the fibres it innervates, which can facilitate considerably when the firing frequency of the small unit is increased (Fig. 22d, e). The large PL unit produced large, fast ejp's in RPL muscle fibres, which are usually at least twice as large as any slow ejp's which may be elicited in the same muscle fibre (Fig. 22d), facilitation is slight but summation of these fast ejp's is common (Fig. 22c,d,f). As in Pagurus (Fig. 21), three groups of muscle fibres were found, slow fibres were innervated by only the small PL unit, intermediate fibres by both small and large units, and fast fibres by only the large PL unit (Table 8).

Altho^ugh fibres from each group can be found through most of the RPL muscle, they are differentially distributed (Table 8), with the small PL unit preferentially innervating dorsal muscle fibres, the large unit ventral fibres, and fibres in between are mixed. The different effects which the two PL units have upon the orientation of the RPL tendon blade (Fig. 22a,b) may thus not only be caused by the different electrical and thus mechanical events elicited in individual muscle fibres by these neural units (Fig. 22c,d,e,f), as is the case in the single PL muscle of Pagurus (Fig. 21), but will also be enhanced by the differential distribution of the two units within the muscle (Table 8).

Table 8 : The innervation of the PL muscle of Carcinus :
the distribution of the slow and fast PL motor neurones.

		MUSCLE FIBRE INNERVATION			
		SLOW	BOTH	FAST	TOTAL
MUSCLE FIBRES	DORSAL RPL	3	12 ⁺	-	15
	MEDIAL RPL	2	9	2	13
	VENTRAL RPL	-	3*	7	10
	PPL	11	5	-	16
TOTAL		46	29	9	54

⁺ several of these fibres showed slow unit ejp's which were much larger than fast unit ejp's in the same fibre.

* these three fibres had very small slow ejp's (/ 0.1 mV amplitude) while maintaining normal sized fast ejp's.

Fig. 23 : The PPL muscle in Carcinus maenas.

a. This PPL muscle fibre, innervated by the slow unit in the PL nerve, exhibits small, facilitating ejp's when CB is stretched (bars).

b. A PPL muscle fibre, innervated by the large unit in the PL nerve, exhibits large, fast ejp's when tension is applied to the AL tendon (bars).

c. & d. Intracellular records obtained from muscle fibres in both parts of the posterior levator muscle in Carcinus maenas, showing that the innervation of both sections is common. c. shows fast unit ejp's elicited when tension is applied to the AL tendon (bars).

d. shows slow unit ejp's firing when the CB strand is stretched (bars).

Vertical scales : a,b, & lower traces of c,d, 4 mV, upper traces of c,d, 8 mV.

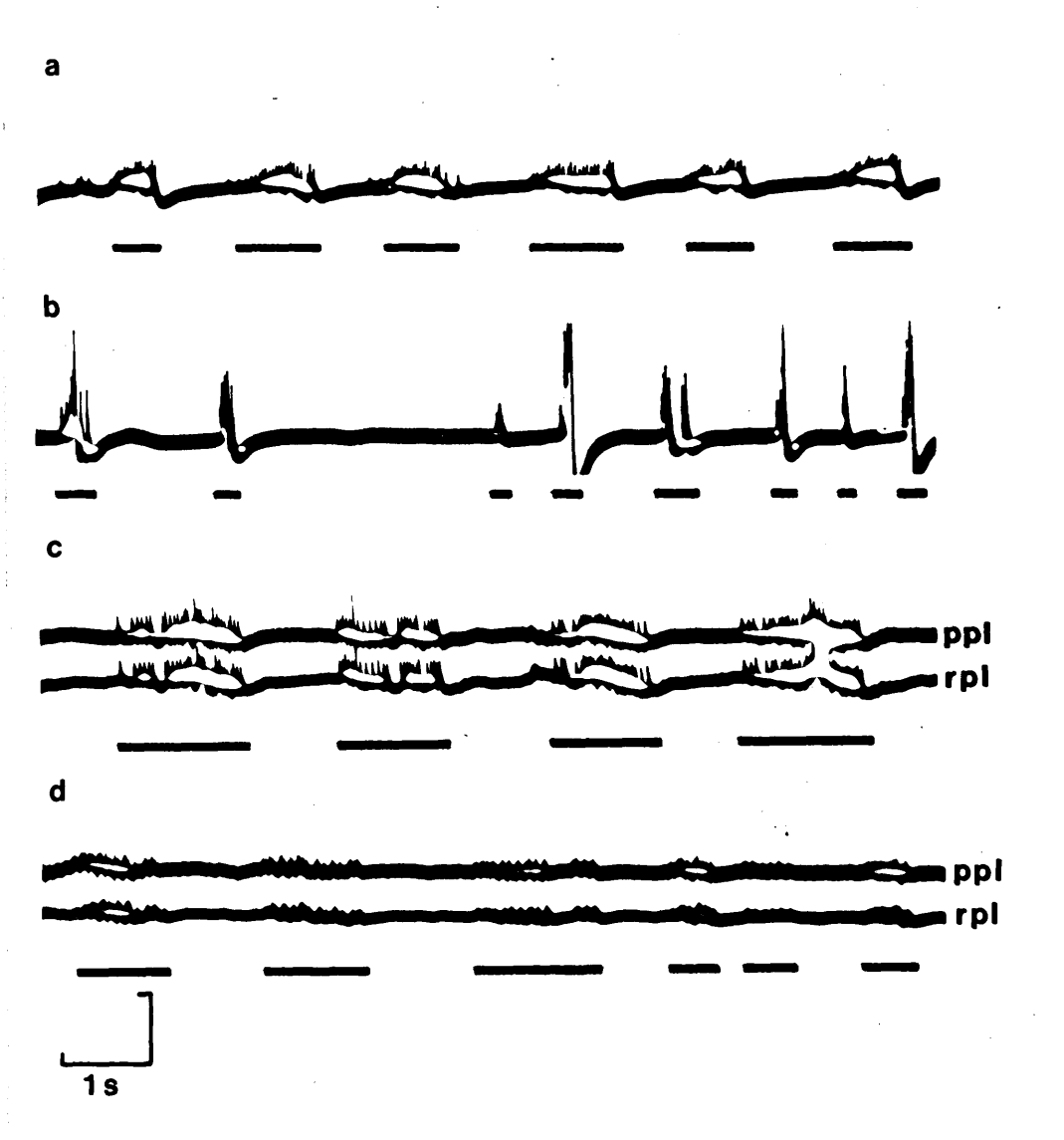

The innervation of PPL in Carcinus was also examined. Both the small and large PL neural units innervate PPL muscle fibres (Fig. 23a,b), with a preference for innervation by the small unit (Table 8).

So far in this study, the two units serving the PL muscles of Pagurus and Carcinus have been differentiated by their relative axonal spike heights, which, when recorded from the cut end of the nerve bundle by a suction electrode are usually, small for the unit responsive to CB stretching (Fig. 19b,c) which elicits small, slow, facilitating ejp's in the muscle fibres which it serves (Figs. 21c, 22d,e) and large spikes for the unit which can be reflexly excited by CSD₁ (Fig. 20c,e,f), eliciting large, fast ejp's in it's muscle fibres (Figs. 21d, 22c,d,f). The distinction between these PL axons is important because of the different effects their activity has upon the orientation of the PL tendon of Pagurus (Fig. 21a,b) and RPL tendon of Carcinus-(Fig. 22a,b), and henceforth will be distinguished on the basis of the post-synaptic events recorded from the muscle fibres which they supply, ie. slow for the small PL unit, and fast for the larger unit.

Responses of the BI levator muscles to injury and autotomy

The natural stimulus causing autotomy in both species is probably damage to the limb, caused by crushing. No specific "autotomy receptor" could be found within the peripheral limb which, when stimulated, causes autotomy. As Hoadley (1937) found, it is possible to cause considerable damage to the limb without autotomy being the immediate result if the main nerve trunks within the limb were not injured, though he did not say whether the damaged limbs were later shed. In this study, we are concerned only with "short-term autotomy" which results immediately, or almost immediately from injury. Injury consisted of crushing the limb strongly enough for the main limb nerves to be compressed or damaged, for then autotomy usually occurs (Hoadley, 1937; Easton, 1972).

Myograms from the BI levator muscles of Pagurus and Carcinus were recorded from restrained individuals where the muscles had been exposed by removing the dorsal coxa-BI arthrodistal membrane.

In Pagurus, crushing the limb elicits firing in both BI levator muscles which is maintained up to the moment of autotomy (Fig. 24a). The fast PL unit was shown to be active not only by the myogram records but also by the visual observation that the PL tendon rotated. In these records it was usually impossible to distinguish the activity of different units. However, in the first section

Fig. 24 : Extracellular myograms recorded from the BI levator muscles when injury of the peripheral limb causes autotomy.

a. Both AL and PL muscles of Pagurus are stimulated by injury of the peripheral limb, and the activity is maintained up to the moment of limb separation (arrow). After autotomy, the electrodes in PL were removed by the levation of the retained BI stump.

b. & c. In Carcinus, the responses of the AL muscle to injury and autotomy have been illustrated by McVean (1974) and Moffett (1975). These records concentrate upon the responses of the two parts of the PL muscle, PPL and RPL.

b. When a hot iron is applied to the merus of the limb it results in activity in PPL ceasing, and just prior to autotomy, firing is elicited in RPL. Cuticular separation actually occurred on the first downwards deflection of the monitor beam (am) and not the later sharp upwards deflection.

c. The post-autotomy response shown in both parts of PL some seconds after limb separation.

tb, 5 pps time base for records b,c.

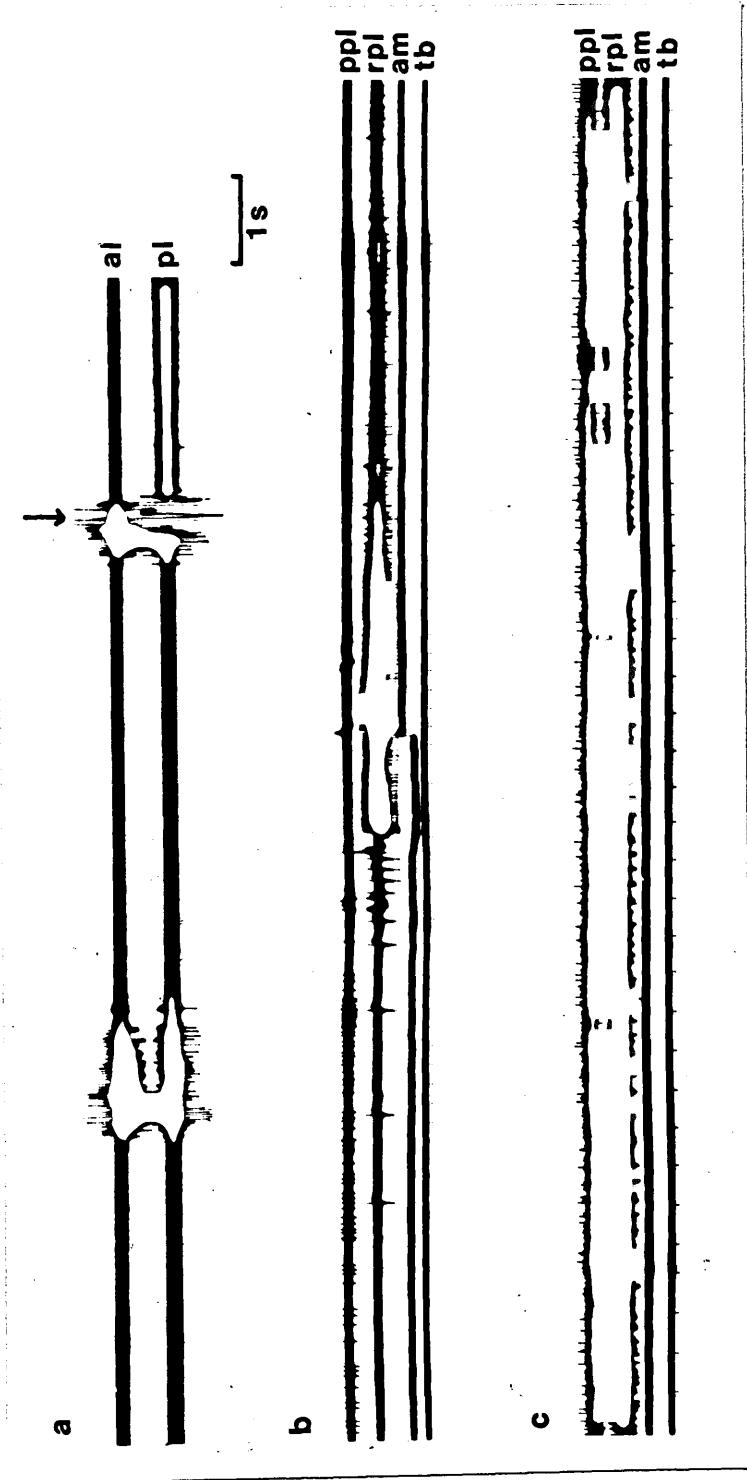

of Fig. 24a it is possible to differentiate the two units which supply the PL muscle.

In Carcinus, muscle recording was confined to the two parts of the PL muscle. McVean (1974) and Moffett (1975) have both described the injury evoked responses in the AL muscle and nerve in some detail, where large high frequency potentials follow injury, and cause considerable tension to be developed in the AL muscle which provides the force necessary to cause cuticular fracture.

The records shown here (Fig. 24b,c) were obtained before the common innervation of the two parts of PL in Carcinus was discovered (Fig. 23c,d), when it was still thought that the two parts, PPL and RPL, might be neurally and functionally separated. With the knowledge of the common innervation, and careful study of the records, what we can see, is not the activity of two separate muscles, but recordings of the separate PL neural units, the fine 50 μ m diameter wire electrodes, in these examples, being selective enough for single units to be recorded; Aided by the differential distribution of the two PL units between the two parts of the muscle, so that recording from PPL reveals it's more common slow PL unit, and the RPL record reveals activity of the fast PL unit, which is prevalent in the medial and ventral regions of that muscle (Table 8).

Attempts to cause autotomy in Carcinus by manually crushing the limb sometimes dislodged the recording

electrodes from the small muscles in which they were situated, so that the stimulus used instead was a hot soldering iron brought alongside the merus, this stimulus had previously been shown to ~~rapidly~~ cause sufficient damage to elicit autotomy (McVean, 1974). The usual responses recorded from the two parts of the PL muscle in Carcinus to such a stimulus consisted, initially, of activity in PPL being increased while RPL remained silent (Fig. 24b). Prior to autotomy, firing of the slow unit in PPL slowed down and eventually shut off, while fast unit potentials in RPL were elicited and maintained up to the moment of autotomy (Fig. 24b).

In this record, immediately following autotomy, the fast unit in RPL fires at high frequency for a short period, then activity in both PPL and RPL gradually builds up to a high frequency (Fig. 24c) which continues for a considerable time, in one example for over twenty minutes. This motor neurones' activity in the PL, which also occurs after autotomy in the AL muscle, is reflected in the dorsal rotation of the BI stump about the coxa-BI joint, which occurs in Carcinus and Pagurus as a normal post-autotomy response.

Activity in the BI muscles during locomotion

Fig. 24 shows how the BI levator muscles of Pagurus and Carcinus act to achieve limb autotomy, but also of importance to this investigation is how these muscles

achieve limb levation during normal locomotion. The role of the two PL units is again crucial. Since Fig. 24a,b shows that the fast PL unit in both species is active just prior to autotomy, if the fast PL unit is also active and thus the PL tendon rotated, during normal locomotion as Clarac & Wales (1970) and Clarac & Coulmance (1971) believe, some doubt^b would be cast upon the role of the PL muscle in autotomy that was outlined earlier.

In Carcinus, since the PPL and RPL innervation is common (Fig. 23c,d), PL muscle recordings during locomotion were obtained from the RPL section of the muscle, where innervation by the fast PL unit is more prevalent than in PPL (Table 8). The experimental arrangement, a small tank of seawater, did not allow the crab a large area in which to sustain rapid locomotion. It has been suggested (Atwood & Walcott, 1965) that slow neural units are responsible for the control of posture and slow locomotion, but that more rapid movements require the introduction of fast units. The records in Fig. 25 were obtained from Carcinus when the crab was suddenly lifted into the air. This results in the animal making rapid paddling motions with its legs when they are separated from the substrate (in these examples corresponding to stepping rates between 0.5 and 2 Hz). No difference was observed between the bursting patterns shown here for suspended paddling and those resulting in normal, but slower locomotion in the tank. This behaviour is not found in Pagurus, and therefore

Fig. 25 : Extracellular myograms recorded from the BI musculature of Pagurus bernhardus and Carcinus maenas during locomotion.

a. Alternate bursts of activity in the AL and DEP muscles of Carcinus during "paddling" motions made by a suspended animal.

b. Records from all three BI muscles of Carcinus during "paddling". The AL and PL muscles fire synergistically, and together, alternate with the DEP muscle.

c. Synergistic bursts of impulses in the two levator muscles of Carcinus during "paddling". The slow unit is mainly responsible for the bursts of firing in the PL muscle, occasional impulses from the fast PL unit are arrowed.

d. During forwards walking in Pagurus, the two levator muscles fire synergistically to levate the limb, in PL only the slow unit fires. The middle trace was not connected to the animal in this record.

e. The DEP muscle of Pagurus alternates with the two levator muscles during forwards walking, in this record alternating bursts of activity are shown by the DEP and PL muscles.

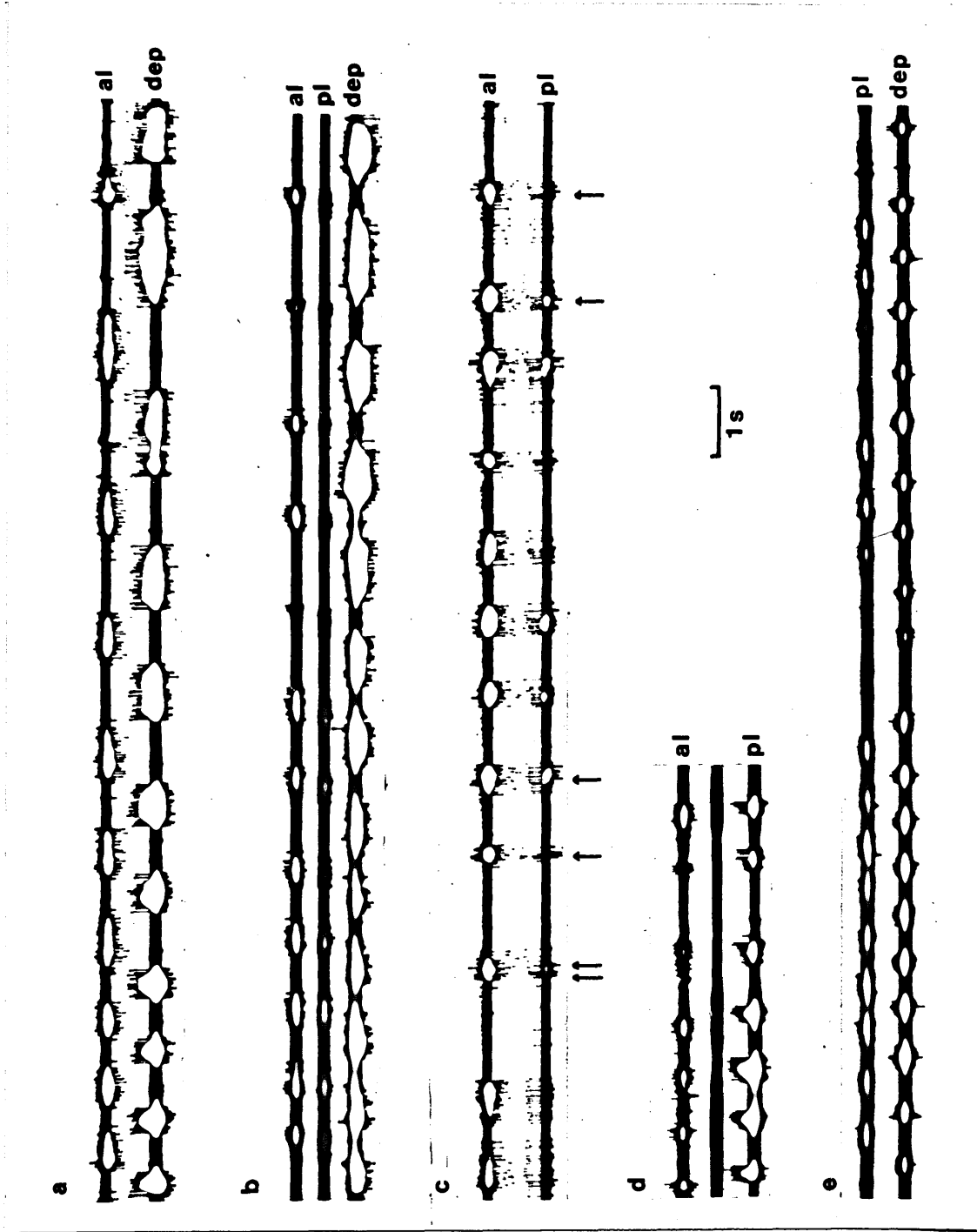

records for this animal were obtained during normal walking around the small tank.

In both animals the two BI levator muscles are antagonised by the BI depressor muscle, and during locomotion, AL and DEP muscles show alternate bursts of activity (Fig. 25a) which result in alternate levation and depression of the limb during the stepping motion. The two levator muscles fire synergistically (Fig. 25 b,c,d) and are antagonised by alternate bursts from the DEP muscle (Fig. 25b,e). In the PL muscles of both species, the levatory bursts are composed by a single unit (Fig. 25b,c,d,e), which is clearly illustrated in Fig. 25c,d where the two BI levators fire in synchronous bursts which correspond with the levatory phase of the stepping motion. This unit was identified as the slow PL unit by it's responsiveness to resistance reflex stimulation elicited from each preparation. Occasional impulses can be observed in Carcinus (arrowed, Fig. 25c) which probably result from firing of the fast PL unit, but these are few and irregular.

The mechanics of the BI cuticle during locomotion and autotomy

Earlier, the basic structure of the BI and the effects of interactions of the BI levator tendons were described (Figs. 17, 18), and two alternatives were suggested for the effect that the position of the PL tendon has upon the force exerted by the AL muscle on the BI. The evidence presented above (Figs. 24, 25) in describing the actions

of the levator muscles causing autotomy and normal levation during locomotion, now allows us to re-examine the anatomy of the BI and levator muscles in order to understand the mechanical events which lead to fracture of the cuticular plug and separation of the breakage plane.

The crucial points are, firstly whether the contractions of the AL muscle are isotonic or isometric, and then, even more important, which of the two PL units are active at which time, for they decide whether or not the PL and RPL tendons rotate (Figs. 21a,b, 22a,b) and therefore the position of the AL tendon head (Figs. 17, 18) and presumably the deployment of force exerted by the AL muscle onto the BI.

During normal locomotion the contraction of the AL muscle will be close to isotonic, where the limb is free to move about the coxa-BI joint and levation results from shortening of the AL muscle fibres (Fig. 25a,b,c,d). In these circumstances, little force would be exerted by the AL muscle onto the cuticle of the dorsal BI. The PL tendon in both species (PL and RPL) during normal locomotion will project perpendicularly from the rim of the BI because only the slow PL unit is active during the PL muscle's levatory bursts of firing (Figs. 21a, 22a, 25c,d,e). Therefore the AL tendon head will be held flush against the BI by AL muscle contraction (except for the position

Fig. 26 : A diagrammatic representation of the dorsal rim of the BI in Pagurus, showing the basic cuticular structure, levator muscle tendons, their interactions and probable effects upon the BI during locomotion and autotomy.

a. During normal locomotion, the AL muscle would shorten to levate the BI about the coxa-BI articulation, little strain would be imposed upon the dorsal BI cuticle. If the limb met an external resistance, contraction of AL could approach an isometric state, and then strain would be imposed onto the rim of the BI through the closed abutting faces (f) into the cuticular ridge (es, solid arrow) and thus around the dorsal BI.

b. When the PL tendon rotates just before autotomy, it opens the abutting faces between AL tendon head and BI, and would thus direct AL force onto the wedge-shaped area of cuticle culminating in the plug connection across the breakage plane (solid arrow), withdrawing this plug to initiate separation of the breakage plane and thus autotomy.

Although this diagram has been based upon a walking leg of Pagurus, it is applicable to Carcinus where the cuticular structure and muscle action are similar.

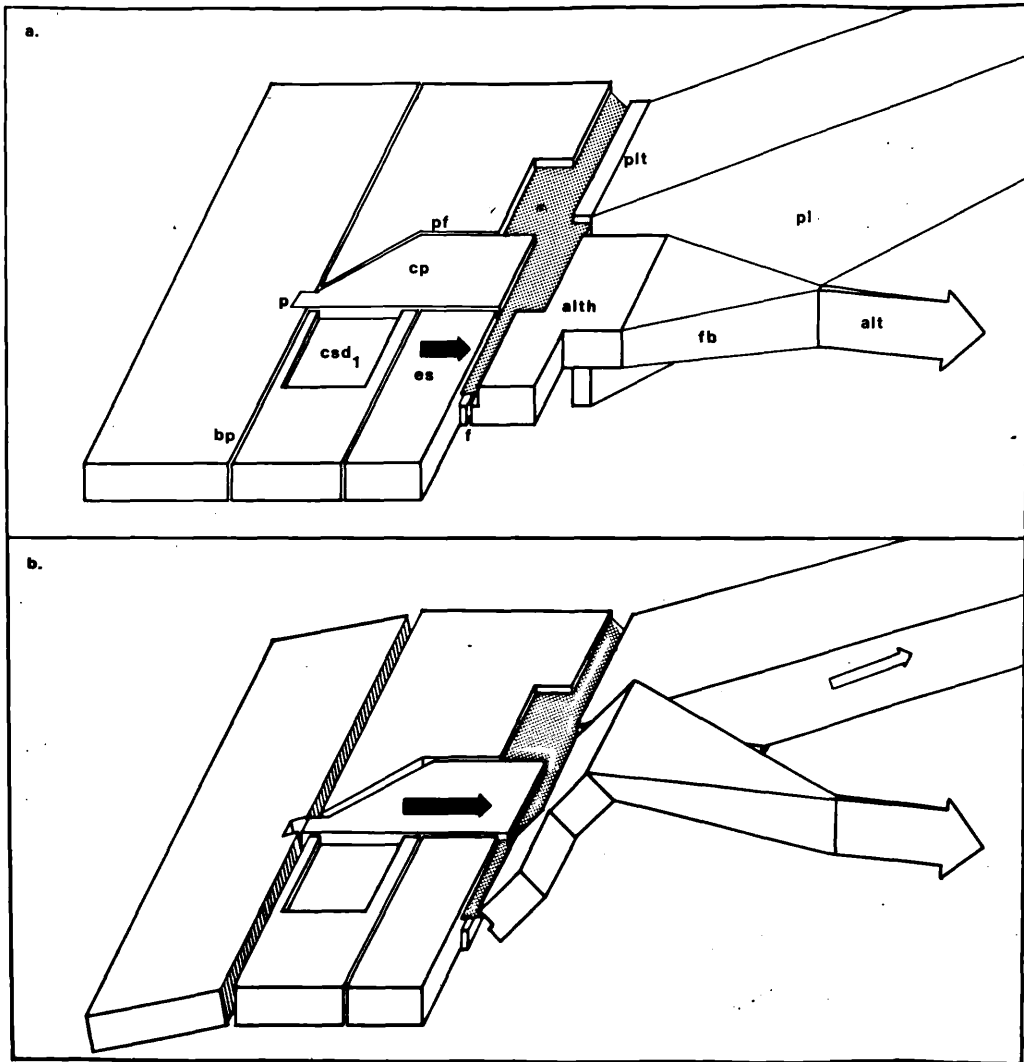
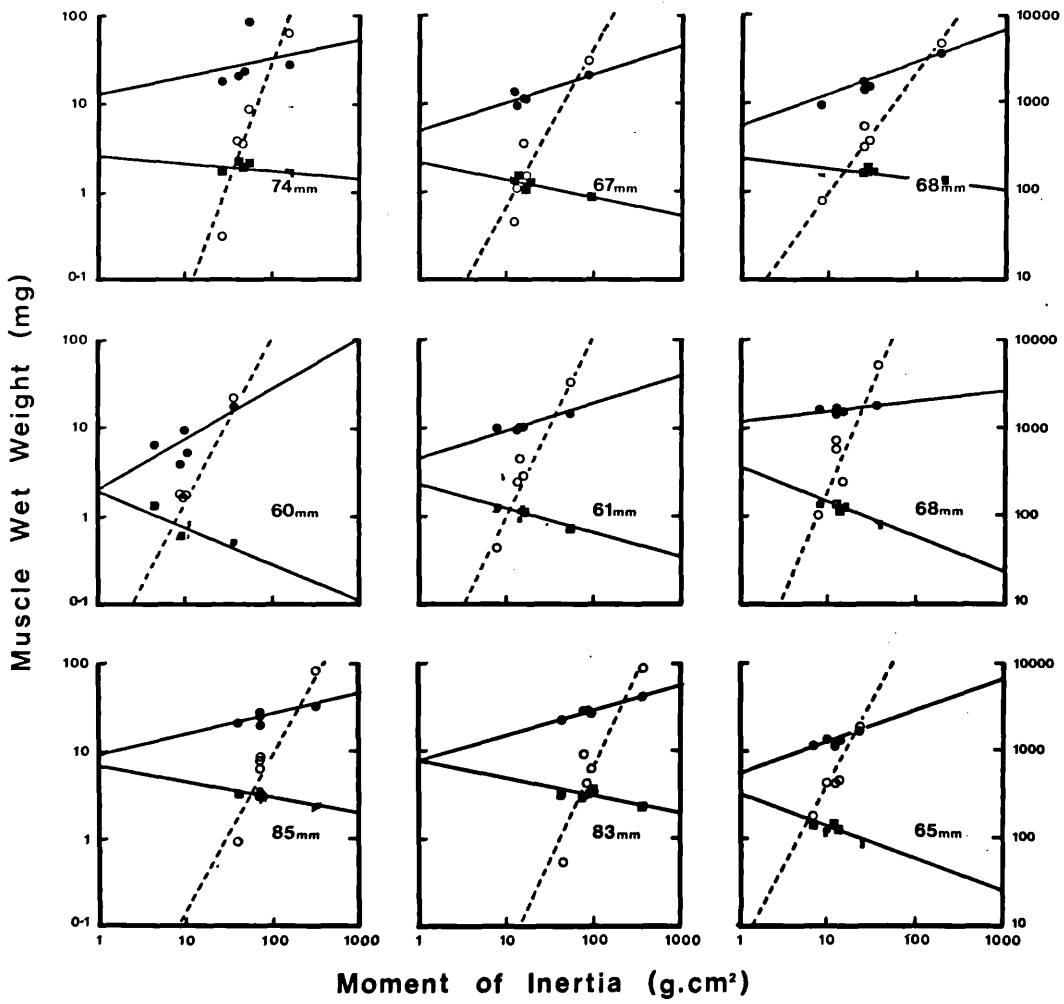

Fig. 27 : Regression of wet weight of the BI levator muscles upon the angular moment of inertia of the limb about the coxa-BI joint in Carcinus maenas. The PPL muscles were smallest in the fifth pereopods and largest in the chelipeds, but of much the same size in the middle three pereopods. These graphs are interpreted as showing that as the inertia of the limb about the coxa-BI joint increases and with it the load which the levator muscles might be expected to bear, that the PPL muscle is more directly concerned with increments in limb inertia than either the RPL or AL muscles. ~~Where~~ ~~The~~ increased wet weight of the PPL muscle, which results from an increase in the transverse section of the muscle and not an increase in it's length, indicates^{ing} that it is more able to aid limb levation than the RPL muscle.

Closed circles, RPL; open circles, PPL; squares, AL. The carapace width of each crab is inset into each graph. Left hand ordinate on each graph refers to the wet weights of PPL and RPL, the right hand ordinate refers to AL.



of extreme elevation) so that the faces between the AL tendon head and the BI are forced together (Fig. 26a).

In both species, however, before autotomy occurs, the fast unit serving the PL muscle is stimulated and the PL tendon blades rotate (Figs. 21b, 22b, 24a,b). This action separates the faces between the AL tendon head and the BI (Figs. 17, 18). At the same time, the AL muscle, excited by injury, ^{stimulating the CNS} causes autotomy (Fig. 24a,b). Since we know that to cause autotomy AL force must be concentrated onto the cuticular plug in the breakage plane, it is reasonable to assume that the rotation of the AL tendon head caused by the rotation of the PL tendon seen prior to autotomy (Fig. 24a,b) results in the AL force being directed through the posterior part of its insertion, into the cuticle triangle which culminates in the plug (Fig. 26b). Fracture of the cuticular connection and withdrawal of the plug, probably aided by shearing forces along Paul's furrow and the anterior margin of the cuticle triangle, initiates separation of the breakage plane and loss of the peripheral limb (Fig. 26b).

The role of the PPL muscle

What needs to be explained is the role of PPL in Carcinus (Fig. 13a,b). The insertion of this part of the PL muscle suggests that it aids limb levation, but since the AL muscle provides the main force for levation why should another levator muscle, which is not found in

Pagurus, be required? In normal limb levation AL muscle contraction will operate in neither perfectly isotonic nor perfectly isometric conditions but somewhere between the two. The isometric condition would be more closely approached when limb inertia is great or when the limb is suddenly accelerated upwards. These conditions could threaten the breakage plane, and the extra strain imposed by the AL muscle onto the BI could be reduced if some of the levatory effort is shared by a synergist that aids levation without straining the crucial parts of the BI. On the basis of this argument, it was predicted that the mass of PPL and thus the force which it can contribute to limb levation should be positively related to limb inertia when the five ipsilateral limbs of a single crab are compared, while the masses of RPL and AL should have less positive relationships to limb inertia increments. This would allow the extra load imposed by heavier limbs, particularly the chelipeds, to be accommodated by PPL without extra strain being imposed by the AL muscle onto the BI. This prediction was confirmed in a series of nine animals (Fig. 27) in which there was found to be a significant difference between the slopes of the regression lines for PPL on limb inertia and regression lines for either RPL or AL ($P < 0.01$, covariance analysis) on limb inertia. It seems probable therefore, that the extra weight and inertia of the heavier limbs are largely borne by increments of PPL muscle mass (Fig. 27).

In the chelipeds of Carcinus (Fig. 13b), where as

well as having increased inertia (Fig. 27), the manipulative functions of these appendages are likely to result in contractions of the AL muscle more frequently approaching an isometric state, the mass of PPL is greatly increased (Figs. 13b, 27). In other species, such as Maia squinado where the walking limbs are long, and heavy, the mass of PPL forms an even larger proportion of the total PL muscle than in Carcinus.

III. THE NERVOUS CONTROL OF AUTOTOMY AND THE ROLE OF CSD₁ IN AUTOTOMY AND LOCOMOTION

The last section described how the BI levators act to cause both autotomy and limb levation during locomotion, with the probable cuticular mechanics which differentiate these events (Fig. 26). What remains to be determined is how are these muscles and events neurally controlled. Are they solely under the command of the central nervous system, or does feedback from peripherally situated sense organs play a part?

In both Pagurus and Carcinus the fast PL unit can be reflexly excited by stimulation of CSD₁ (Fig. 20c,e,f). Such stimulation usually arises from high levels of isometric tension in the AL muscle straining the dorsal BI (Fig. 20b, Clarac & Wales, 1970, Clarac et al., 1971, Moffett, 1975). Strains of this magnitude are likely to be imposed on the BI prior to autotomy when the AL motor

neurones are stimulated by injury. So, is the fast PL unit activity which rotates the PL and RPL tendons and directs AL force onto the cuticular plug prior to autotomy stimulated by the central nervous response to injury which also causes AL muscle contraction (McVean, 1974), or do the injury-induced contractions of the AL muscle reflexly stimulate the fast PL unit via CSD₁? To answer this question the central nervous response of BI levator motor neurones to injury and the effects of AL tension causing cuticular fracture on these motor neurones have to be separated.

The central nervous response to injury

When the limb is grasped and crushed while the motor neurones supplying the BI muscles are isolated from feedback from either CB or CSD₁, the central nervous response to limb injury is revealed. This response could either be directly driven by the nervous discharge caused by peripheral damage, or such a discharge could generate, within the central nervous system, a specific command output to the BI muscle motor neurones. In either case the response is produced when isolated from sense organs situated in the BI and will be regarded as, and called, the central nervous response to injury. Isolation of this response in Pagurus was achieved by severing the attachment of the AL tendon head from the BI, so that injury induced contractions of the muscle would have no effect upon the BI. In Carcinus,

Fig. 28 : Responses of motor units serving the BI musculature to injury of the peripheral limb when isolated from sensory feedback from the BI,

a. & b. In Carcinus, injury was caused by crushing the peripheral limb between the propus and merus. If the limb is gently squeezed firing is elicited in AL and DEP units (a,b) and in PL the slow unit is stimulated (a). When the pressure is increased, units supplying PL and DEP are inhibited while AL units fire at high frequency (a,b). This change in the response of the BI motor neurones to injury of the peripheral limb results when the main nerve trunks within the limb are damaged. This stimulus results in autotomy when applied to an intact animal (Easton, 1972), and is known to occur when the peripheral nerves are damaged from earlier experiments where the peripheral nerves were exposed and then crushed.

c. When the main peripheral nerve trunks within the merus of Pagurus 3LP are severed, there is a sustained burst of high frequency firing of units serving AL, and although initially stimulated, units serving PL are silenced for most of the duration of the AL injury response (the small unit visible in PL firing through the injury response results from artifactual crosstalk with the AL muscle).

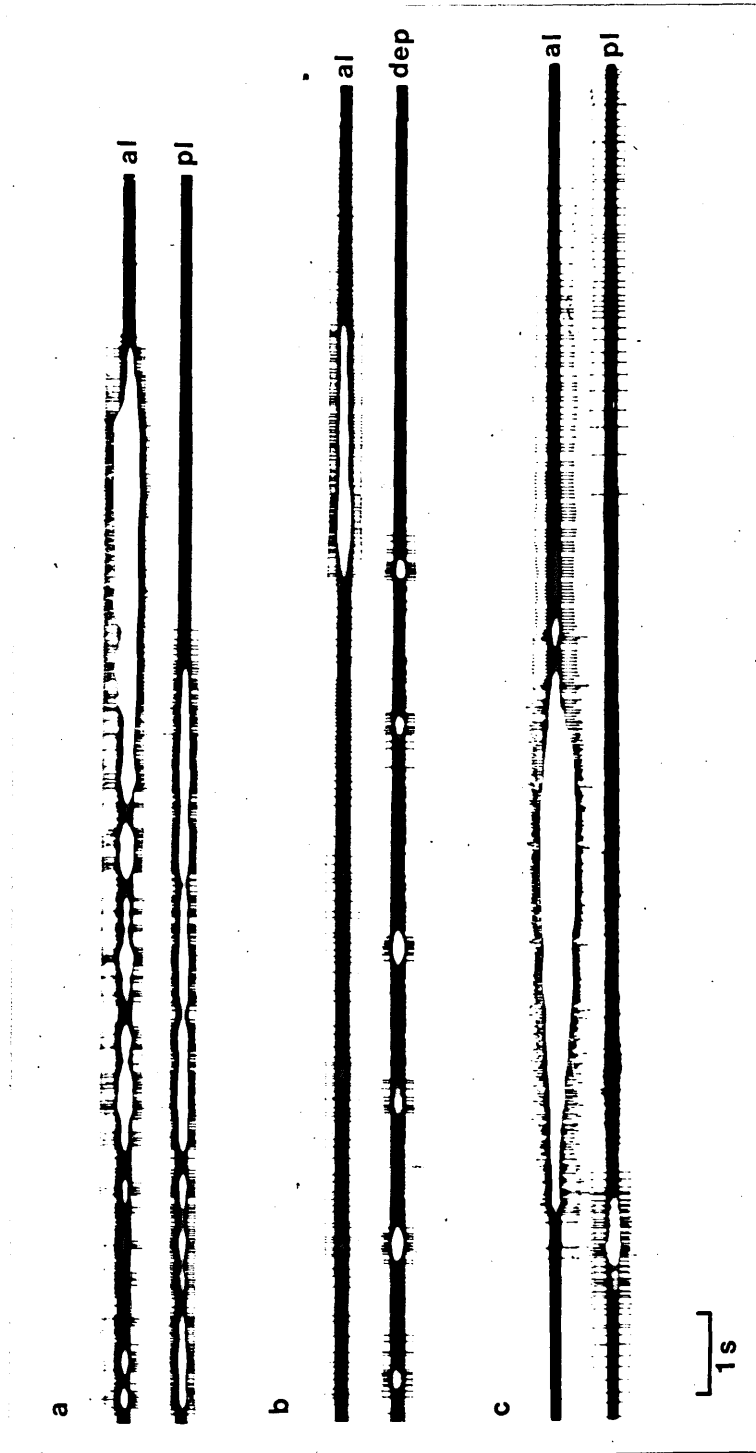

the AL muscle was immobilised by cutting the nerve bundle containing it's motor axons and recording from the severed end.

The response to injury is a two stage process, the central nervous system differentiates between gently squeezing the limb and stronger stimuli which crush the main nerve trunks within the peripheral limb (Fig. 28). Damage to the nerve trunks is usually required to cause autotomy (Hoadley, 1937; Easton, 1972), and in Carcinus, when the nerves are crushed the PL slow unit (Fig. 28a) and units serving the DEP muscle (Fig. 28b), which were both stimulated by squeezing the limb, are inhibited, while units serving the AL muscle fire a burst of very high frequency impulses which are easily distinguishable from the milder excitation caused by squeezing the limb (Fig. 28a,b). In Pagurus, a more abrupt stimulus was achieved by exposing the peripheral nerve trunks within the merus and severing them with a pair of fine scissors. The result is similar to the response seen in Carcinus (Fig. 28a), AL units fire a high frequency burst when the nerves are cut, and except for an initial short period of stimulation, the units in PL are inhibited (Fig. 28c).

These responses (Fig. 28a,c) do not correspond to the muscle activity shown to occur at autotomy in either Carcinus (Fig. 24b) or Pagurus (Fig. 24a). The difference lies in the absence of activity in the fast PL unit for Carcinus (Fig. 28a), in Pagurus although both PL units are

initially stimulated by injury, they are rapidly shut down (Fig. 28c).

Reflex responses elicited by AL tension leading to cuticular fracture

A prerequisite for successful autotomy is that the limb be held, either by another animal or externally braced (usually against the thorax), so that AL muscle contraction approaches an isometric state and may thus be directed onto the BI cuticle (Fredericq, 1883, 1892, Wood & Wood, 1932, McVean, 1973, Moffett, 1975). Isometric tension in AL tendon stimulates CSD₁ (Fig. 20b), and when that tension is maintained until fracture of the breakage plane is achieved, the CSD₁ sensory response is also maintained (Fig. 29a, Clarac et al., 1971, Moffett, 1975). Stimulation of CSD₁ in turn evokes firing in the fast PL unit (Fig. 20c,e,f, Clarac & Wales, 1970, Moffett, 1975). As such reflex firing in the fast PL unit is maintained when sufficient tension is applied to the AL tendon to cause cuticular fracture and artificial autotomy (Fig. 29c,e, Moffett, 1975), the CSD₁-PL reflex loop could be responsible for the PL muscle activity seen at autotomy (Fig. 24a,b) although it is absent from the central nervous response to injury (Fig. 28a,c).

Fig. 29d shows the responses of AL and PL motor neurones in Carcinus to a maintained tension applied to the AL tendon which resulted in cuticular fracture followed

Fig. 29 : Sensory and motor responses in BI levator units to tension applied to the AL tendon causing cuticular fracture and artificial autotomy.

a. When a strong isometric tension is applied to the AL tendon in Carcinus, CSD₁ responds with maintained firing, the sudden release of such tension when the cuticle fractures results in cessation of firing (arrow). The post-fracture response declines rapidly and may result from damage to the sense organ.

b. In Pagurus, a mild tension applied to the AL tendon (bars) increases the firing frequency of the slow unit in the PL nerve.

c. When the tension applied to the AL tendon of Pagurus is increased, the fast PL unit is recruited and the slow PL unit inhibited. On cuticular fracture a high frequency barrage of impulses occurs in both PL and AL nerves. Until this barrage, AL motor units were not stimulated by tension applied to the AL tendon.

b. & c. form a continuous record.

d. An experiment where the events of cuticular fracture and limb separation, which normally occur together as in e., were separated by nearly eight seconds. Discussed in the text.

e. In Carcinus, the response to maintained tension which produces fracture is similar to the events in Pagurus (c.), except that the slow PL unit in Carcinus does not respond to AL tension. In both species, the firing of the fast PL unit is maintained up to fracture.

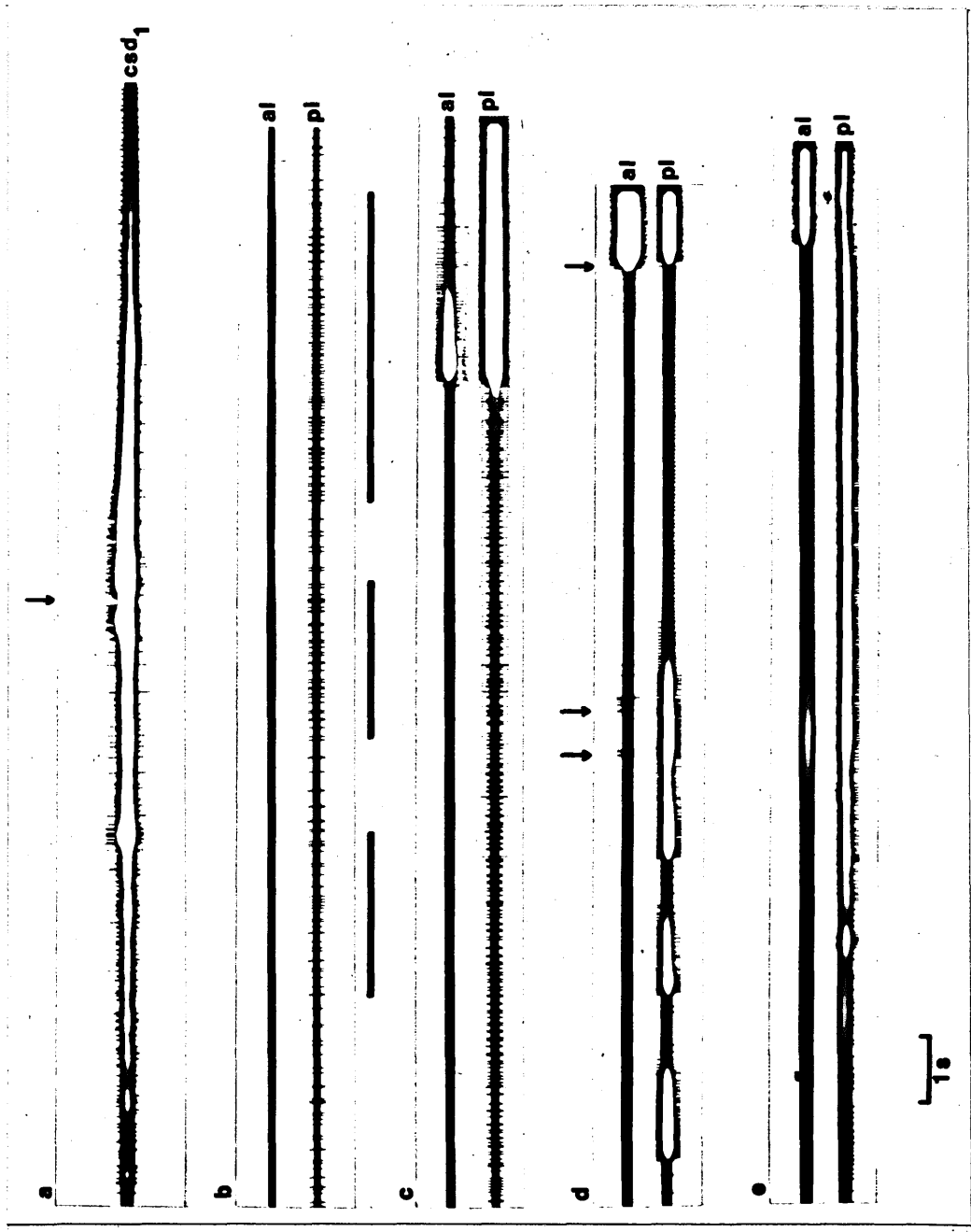

18

by separation of the limb. These two events, which constitute the act of autotomy usually occur together, but are here separated by nearly eight seconds. Cuticular fracture was initiated by the withdrawal of the cuticular plug (first arrow), the fracture then spread around the breakage plane (second arrow) and eventually the limb peripheral to the breakage plane fell away, severing the limb's main nerve trunks as they pass through the autotomy membrane (third arrow). This record reveals that when the strain is removed from CSD₁ by cuticular fracture (Fig. 29a, Moffett, 1975), the reflex loop onto the fast PL unit is no longer stimulated and the slow PL unit returns (Fig. 29d), and that the sudden silence seen in both PL units on artificial autotomy before the high frequency post-autotomy response (Fig. 29c,e) follows not from cuticular fracture as Moffett (1975) had thought, but occurs when the limb falls away and the peripheral nerves are severed.

AL units in Pagurus and Carcinus show no response to tension applied to the AL tendon except for a few potentials on cuticular fracture (Fig. 29c,d) and the post-autotomy barrage resulting from nerve severance (Fig. 29c,d,e).

The effect of CSD₁ stimulation upon AL motor neurones

While the effects of CSD₁ stimulation upon the PL muscle and the fast PL unit have been clearly demonstrated, here in Figs. 20c,e,f, 21b, 22b, 29c,d,e and elsewhere

by Clarac & Wales (1970) and Moffett (1975), available data concerning the influence of CSD₁ on AL motor neurones is less reliable (Clarac et al., 1971, Moffett, 1973, 1975). Experiments described here so far have shown no AL motor neurones responding to AL tension (Figs. 20f, 29b,c,d,e), but in none of these experiments has AL been driven by either central nervous or sensory reflex input, so that although these records fail to demonstrate a positive influence of CSD₁ upon AL units as was suggested by Clarac (cited in Clarac et al., 1971, 1976) and Moffett (1975), a possible inhibitory influence, which was suggested by Moffett (1973), has not been examined, nor the possibility of a normally sub-threshold but excitatory influence which may facilitate any ongoing activity.

An indication of the effect that CSD₁ stimulation has upon AL units was first obtained in a preparation of Pagurus where two units serving AL were firing tonically. When the CSD₁-fast PL unit reflex loop was stimulated by applying pressure to the CSD₁ membrane, activity in both AL units was inhibited (Fig. 30a,b). In the PL nerve it is difficult to see whether the PL slow unit is reflexly inhibited, excited, or ignored when the fast PL unit is stimulated, since in these slow time base records (1" per sec.), the burst of fast PL unit impulses obscures activity in the slow PL unit. These experiments originally recorded on magnetic tape, were re-filmed with a faster time base of 2" per second to spread out the events, and

from these films the instantaneous frequency was calculated and histograms plotted for each of the units active in both AL and PL nerves (Fig. 30).

In this experiment, the frequency histograms reveal that when the fast PL unit is stimulated (Fig. 30a,d), the firing frequency of the slow PL unit is reduced (Fig. 30c). Initially, both the smaller AL unit and the slow PL unit are firing at a frequency between 20-30 Hz, both are inhibited on stimulation of CSD₁ and excitation of the fast PL unit. When stimulation ceases, the slow PL unit rapidly returns to a high firing frequency and reaches the pre-stimulus rate within 3-4 seconds (Fig. 30c). The smaller of the AL units, on the other hand, does not begin to fire again until at least four seconds after the CSD₁ stimulus ceased (Fig. 30a,b) and in this record has not returned to its original firing rate after nine seconds (Fig. 30a,c). The larger AL unit is even slower to resume firing (Fig. 30a) and was not plotted.

Since tonic activity in levator motor neurones was inhibited by CSD₁ stimulation which reflexly excites the fast PL unit (Fig. 30), could this stimulation inhibit AL and PL units which were being driven by a sensory reflex input? This was investigated by driving AL units and the slow PL unit with resistance reflex excitation by alternately stretching and relaxing the CB chordotonal organ strand while stimulating CSD₁, in Carcinus by applying tension to the AL tendon and in Pagurus by applying

Fig. 30 : Tonic activity in the nerves supplying both BI levator muscles in Pagurus bernhardus is inhibited when the CSD₁-fast PL unit reflex loop is stimulated by distortion of the soft membrane overlying CSD₁ with a fine probe (bars).

a. Oscilloscope record of activity in both BI levator nerves.

b-d. Instantaneous frequency histograms of activity in individual motor units. Occasionally one of the motor units would fire at a rate greater than 100 ips, such events are shown on these histograms as firing rates of 100 ips.

b. AL tonic unit.

c. Slow PL unit.

d. Fast PL unit.

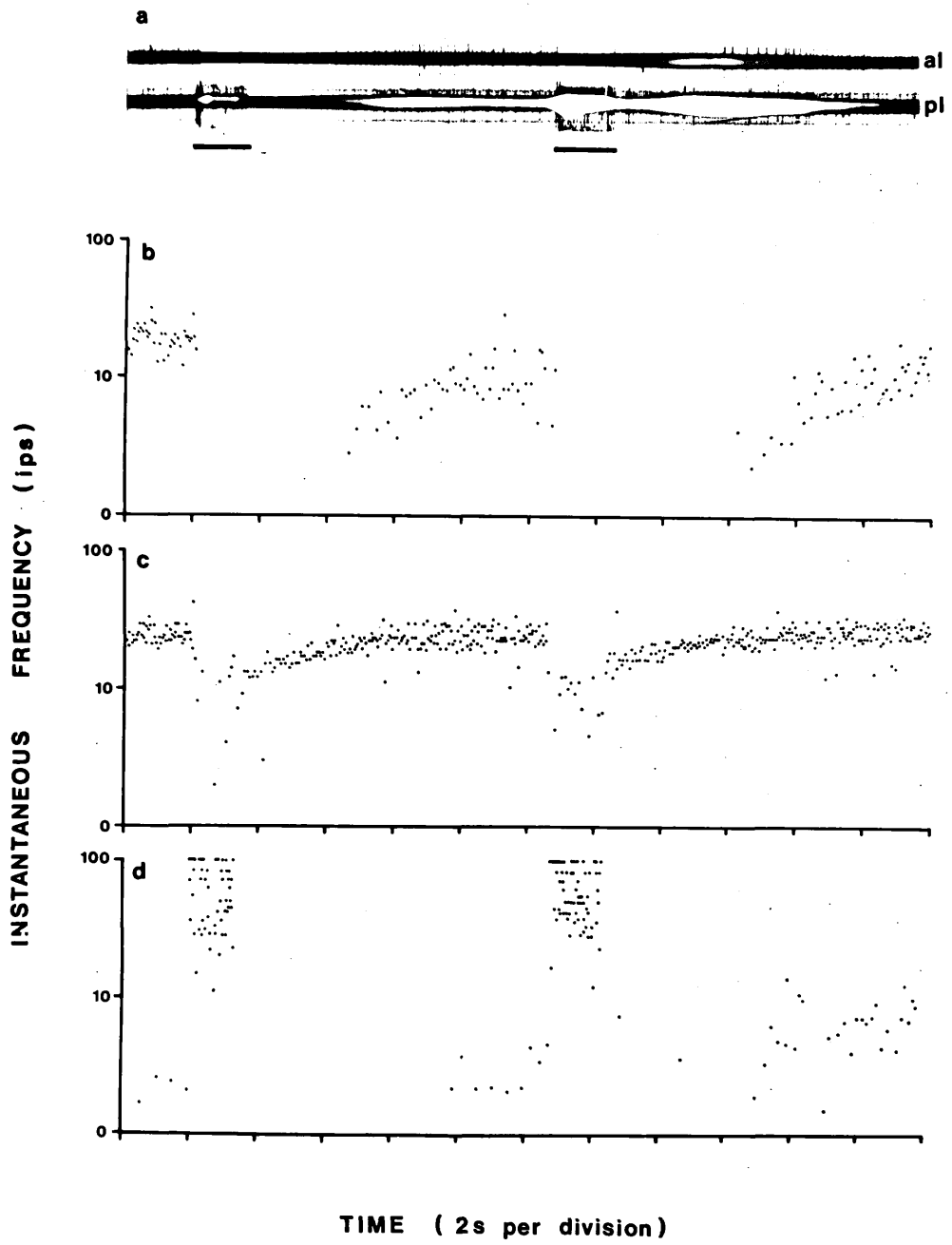

Fig. 31 : Resistance reflex activity was evoked in the nerves supplying the two BI levator muscles in Pagurus bernhardus by alternately stretching and relaxing the CB chordotonal organ strand (arrows). While such stimulation was maintained, the CSD₁-fast PL unit reflex was elicited by distorting the CSD₁ membrane with a fine probe (bars), whereupon the resistance reflex activity was inhibited.

a. Oscilloscope record of activity in both BI levator nerves.

b-e. Instantaneous frequency histograms of activity in individual levator motor units. Occasionally the motor units could fire at a rate greater than 100 ips, such events are shown on the histograms as firing rates of 100 ips.

b. Large AL unit.

c. Small AL unit, which is too small to be clearly visible on the record shown in a.

d. Slow PL unit.

e. Fast PL unit.

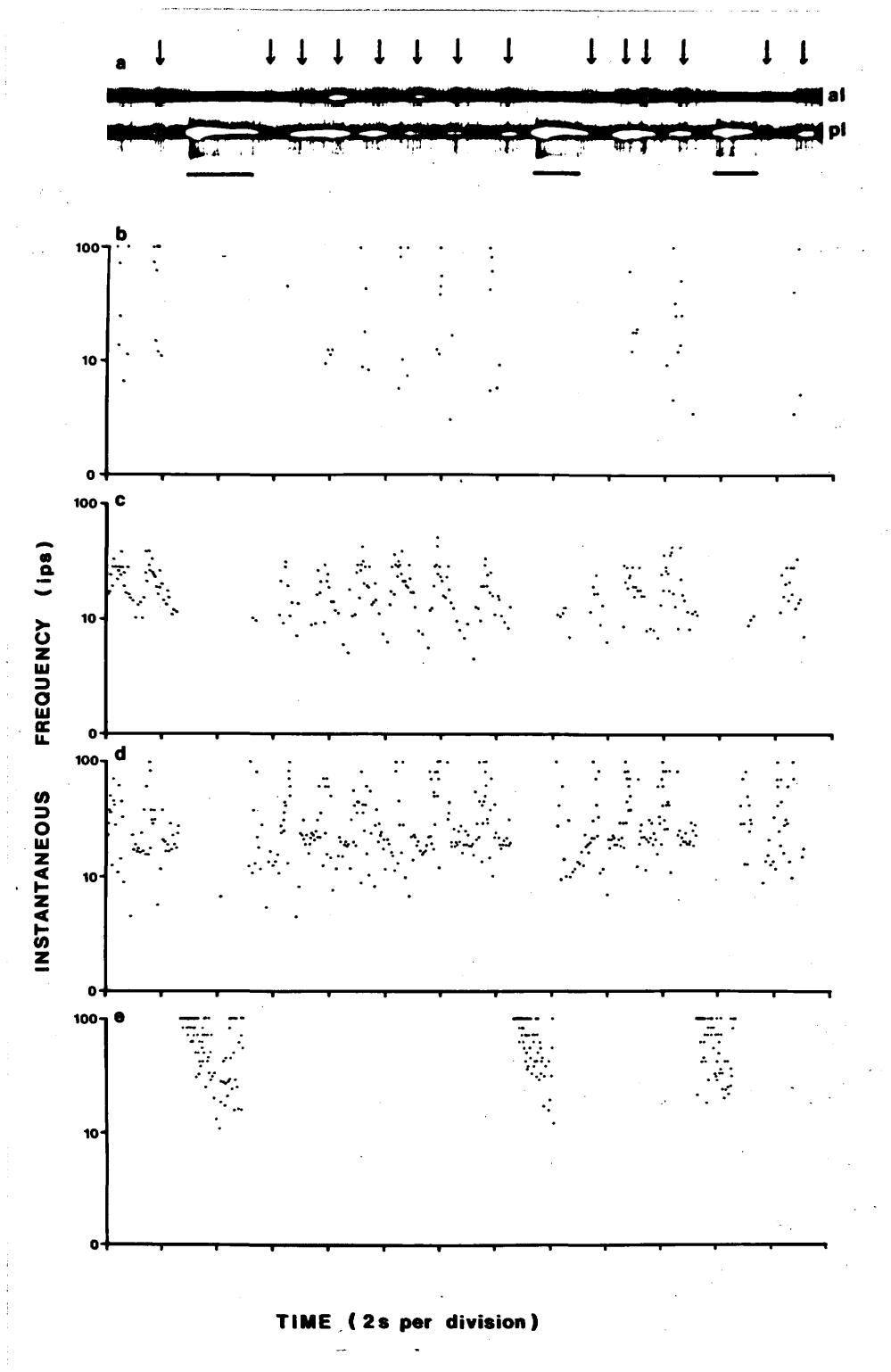

Fig. 32 : The same experiment as shown in Fig. 31, showing the effects of CSD₁ stimulation upon resistance reflex activity in BI levator motor units in Carcinus maenas. Arrows indicate stretching of the CB strand, and bars indicate tension applied to the AL tendon stimulating CSD₁.

a. Oscilloscope record of activity in both BI levator nerves.

b-e. Instantaneous frequency histograms of activity in individual levator motor units. Occasionally the motor units could fire at a rate greater than 100 ips, such events are shown on these histograms as firing rates of 100 ips.

b. Large AL unit.

c. Small AL unit.

d. Slow PL unit.

e. Fast PL unit.

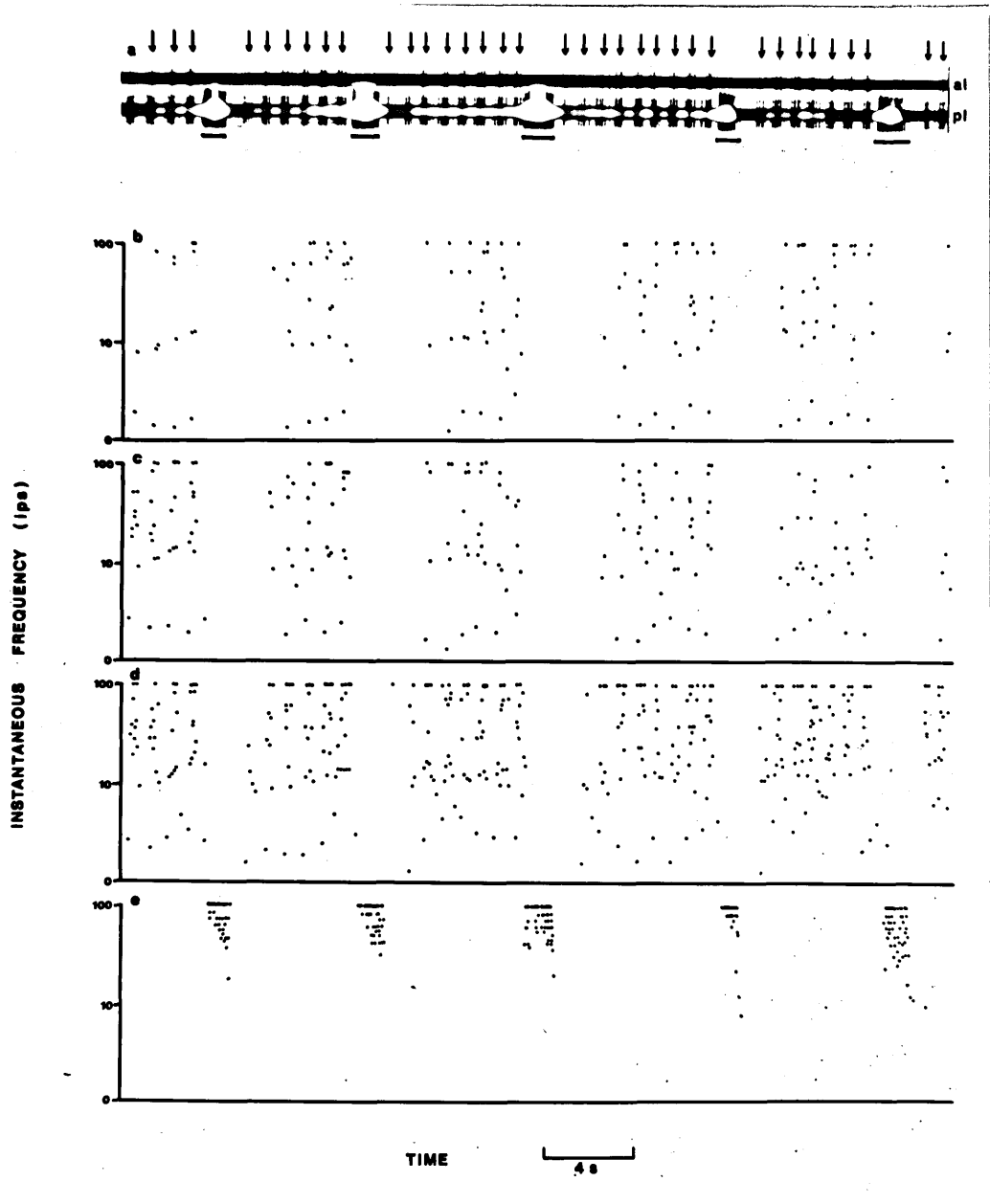

pressure to the CSD₁ membrane. Figs. 31 & 32 show the results of such experiments on Pagurus and Carcinus respectively.

When CSD₁ and the fast PL unit are stimulated (Figs. 31a,e, 32a,e) resistance reflex excitation and ongoing tonic activity in AL units and the slow PL unit are completely inhibited (Figs. 31a,b,c,d, 32a,b,c,d). The return of reflex activity after the cessation of CSD₁ stimulation is again delayed, though more so for some units than for others. In Pagurus, the slow PL unit produces it's usual resistance reflex response as soon as CSD₁ stimulation ceases (Fig. 31a,d). In Carcinus the slow PL unit usually responds normally by the second cycle of CB stretch-release (Fig. 32a,d). As far as AL units are concerned, in Pagurus the smaller unit requires two CB cycles, the larger unit three or four CB cycles (Fig. 31a,b,c). In Carcinus, both AL units take two or three cycles to return to their normal, pre-CSD₁ stimulation, resistance reflex activity (Fig. 32a,b,c).

Therefore, not only will CSD₁ reflexly excite the fast PL unit and inhibit ongoing tonic activity in AL motor neurones (Fig. 30) but it will also inhibit resistance reflex excitation of these neurones (Figs. 31, 32). This inhibition continues once the stimulation of the sense organ has ceased since normal activity is only regained after several seconds in some units. The failure

of resistance reflex responses during CSD₁ stimulation and the gradual return of full responses after cessation of CSD₁ stimulation do not result from manual bias in stimulus application.

The role of CSD₁ in limb autotomy and locomotion

In order to achieve autotomy after limb injury a crab requires a resistance against which to brace the limb (Fredericq, 1883, Wood & Wood, 1932). In such conditions contraction of the AL muscle would approach an isometric state, and if strong enough, would stimulate the CSD₁-AL inhibition loop (Figs. 30, 31, 32). The contraction of the AL muscle, however, must be maintained and concentrated onto the cuticular plug if autotomy is to take place. There are two ways in which this can be achieved. The first possibility is that the CSD₁ induced reflex loops to AL and PL are centrally inhibited on injury to the limb, as was suggested by Moffett (1975), but this would also mean that the fast PL unit would not be excited since it is absent from the central nervous response to injury (Fig. 28a,c), and the PL tendon therefore unrotated at autotomy, which, however, does occur (Fig. 24a,b). The second possibility is that the CSD₁ reflex loops remain intact, while the AL muscle contraction necessary to cause autotomy is excited by an alternative pathway.

It is possible to examine the effects of injury upon the CSD₁ reflex loops by, in Carcinus applying and

Fig. 33 : The results of experiments examining the role of CSD_1 in limb autotomy in Pagurus bernhardus.

a. & b. Applying known weights to the AL tendon blade.

a. 250 g applied to the AL tendon blade (bars) with the abutting faces between the AL tendon head and the BI separated (Fig. 17b) elicits firing in the PL nerve for the duration of the stimulus.

b. 250 g applied to the AL tendon blade (bars) with the abutting faces closed (Fig. 17a) elicits few impulses in the PL nerve.

c. A record obtained from the PL nerve when a sustained stimulus was applied to CSD_1 (bar), during which the peripheral limb is injured (arrow) shows that firing of the fast PL unit can be maintained through the normal injury response of PL motor neurones (Fig. 28c).

d. When the CSD_1 sense organ has been ablated the response of the PL muscle, (in an otherwise intact animal) to injury of the limb is cut short, compared with the maintained response shown in Fig. 24a.

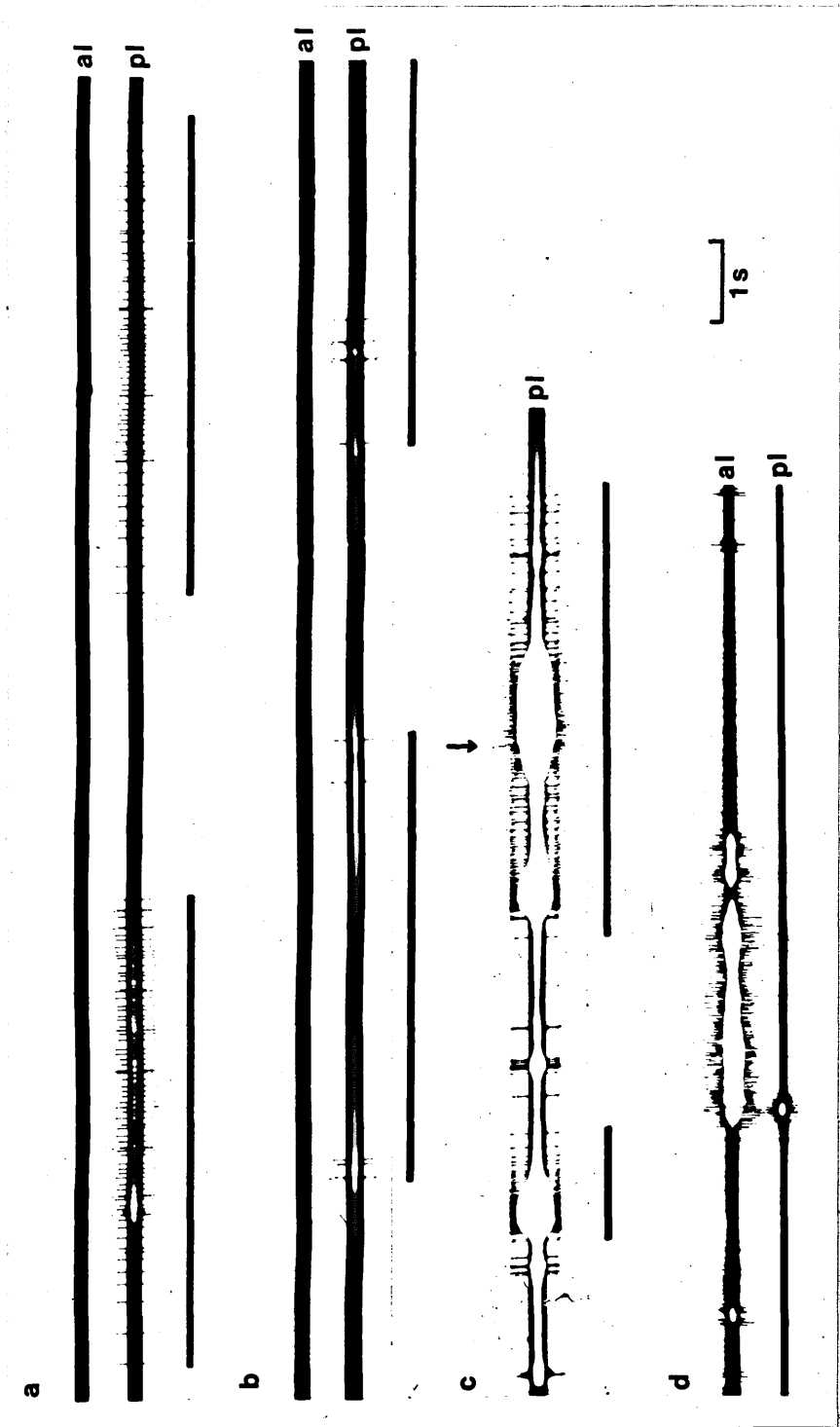

maintaining sufficient tension to the AL tendon to stimulate CSD₁ and it's reflex loops, in Pagurus operating CSD₁ and it's reflex loops by maintaining pressure on the CSD₁ soft membrane, then in both species crushing the peripheral limb to generate the central nervous response to injury. If the first alternative is correct, AL units will fire at the high frequency typical of the normal central nervous response to injury (Fig. 28a,c) while fast PL unit activity, induced by CSD₁ stimulation (Figs. 20c,e,f; 29c,d) would be inhibited on injury to the limb. However, Figs. 33c; 34a, show that when limb injury and CSD₁ stimulation are combined, the CSD₁-PL reflex loop continues to fire, and AL units are also excited by injury. The second alternative is shown to be the correct one. The CSD₁ reflex loops are not inhibited upon injury to the peripheral limb, while AL units are excited via a pathway within the central nervous system which over-rides or bypasses CSD₁ induced inhibition of AL motor neurones.

In Pagurus, the central nervous response to injury initially stimulates both PL neural units before inhibiting them (Fig. 28c), and thus the PL tendon rotates and immediately directs the AL force induced by injury onto the cuticular plug (Fig. 26b). It was noted earlier that manual stimulation of the CSD₁ membrane in Pagurus, adjacent to the plug, stimulates the CSD₁-fast PL unit reflex (Fig. 20c). Concentration of force onto the plug

should thus operate this reflex more easily than when the same force is spread around the dorsal rim of the BI. The rotation of the PL tendon which was initiated by the central nervous response to injury would be maintained by positive feedback. In essence, the CSD_1 -PL reflex should have a lower mechanical threshold when the abutting faces between the AL tendon head and the rim of the BI are separated by rotation of the PL tendon (Fig. 17b), than when they are closed and AL force directed through them into the cuticular ridge region of the dorsal BI (Figs. 17a, 26a).

This hypothesis was tested by hanging known weights onto the AL tendon blade of Pagurus when the abutting faces were closed with the AL tendon head flush with the BI, then the same weight was applied when the faces were separated with the AL tendon head in the rotated position (Fig. 17b). The results from such an experiment can be seen in Fig. 33a,b which reveals that when the same tension is applied to the AL tendon, the CSD_1 -PL reflex produces more rapid firing in the PL nerve when the faces are separated (Fig. 33a) than when the faces are together (Fig. 33b). An increased frequency can be obtained from the CSD_1 -PL reflex when the abutting faces are together, but a much greater tension has to be applied, opening the faces lowers the mechanical threshold for this reflex.

If CSD_1 , in Pagurus, is involved in the maintenance of PL tendon rotation on injury, as this evidence suggests,

Fig. 34 : Experiments designed to examine the role of the CSD₁ sense organ during autotomy and locomotion in Carcinus maenas.

a. Responses of levator motor units recorded from the severed ends of their nerve trunks when a sustained tension is applied to the AL tendon (bar) to stimulate firing of the fast PL unit during which the peripheral limb was injured (arrow).

b. & c. Recording from the CSD₁ afferent nerve in a limb which was left free to move, and levation of the BI and peripheral limb about the coxa-BI joint mimicked by pulling on the AL tendon. These two films form a continuous record. Unrestricted levation of the BI and limb elicit no clear response from CSD₁ (b.), but when levation is prevented by an external resistance (bars, c.), CSD₁ units are stimulated.

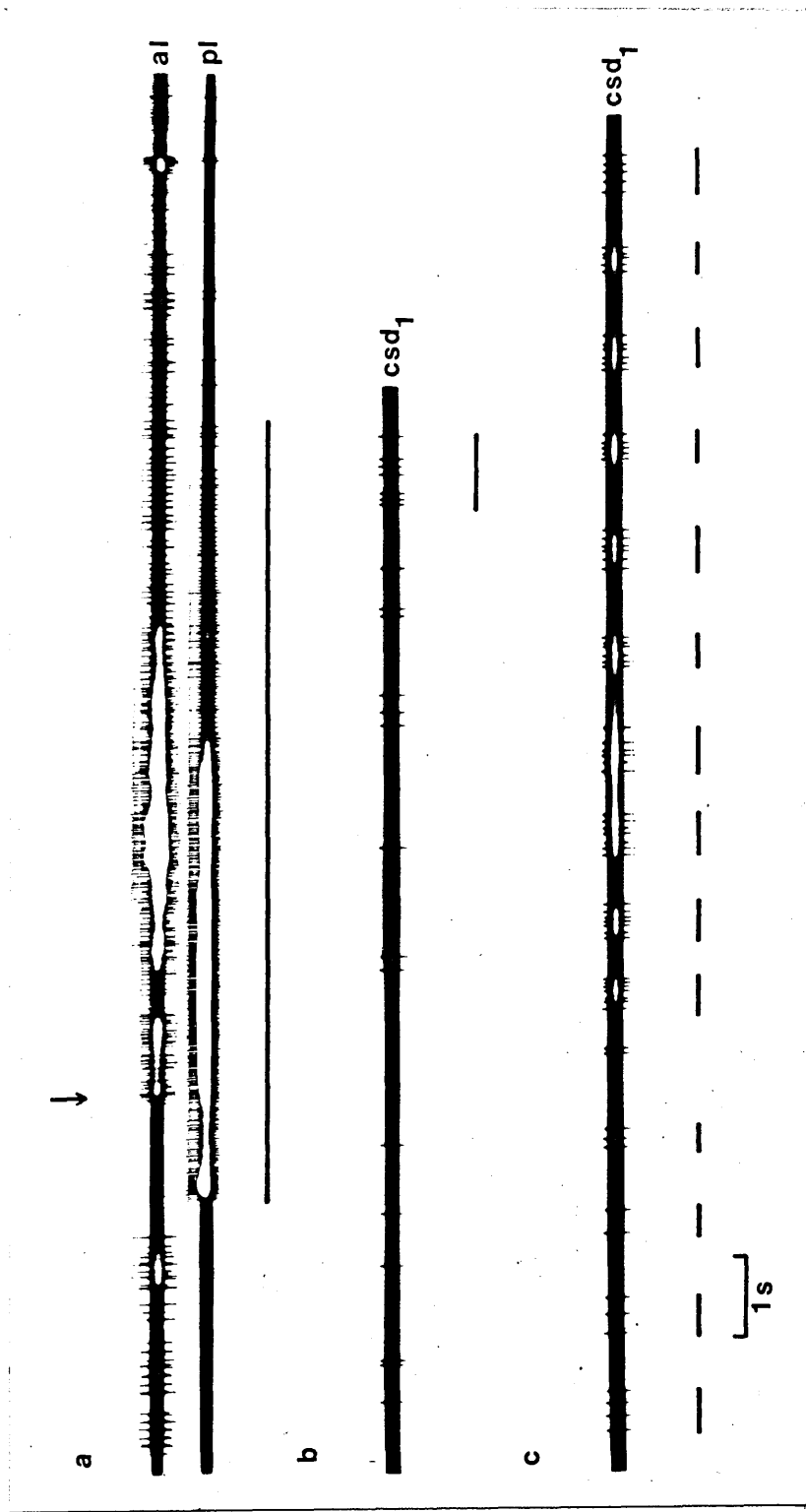

the ablation of CSD₁ should lead to a foreshortening of the muscle's response to injury in an otherwise intact animal; only the short-term excitation of PL resulting from the central response to injury should be observed. This prediction was confirmed (Fig. 33d).

In Carcinus, the fast PL unit is not stimulated during the central nervous response to injury (Fig. 28a) and is not recruited during autotomy until just before limb separation (Fig. 24b). Therefore it is thought that the CSD₁-PL reflex in Carcinus operates to achieve cuticular fracture in a slightly different manner than in Pagurus, and will be discussed in a later section.

We have seen how CSD₁ can operate under conditions of considerable cuticular strain imposed by isometric contractions of the AL muscle, but might not CSD₁ also have a more general role in locomotion? For instance it might monitor slighter strains imposed onto the limb and so organise suitable adjustments to the locomotor programme. Clarac (1976) has shown that CSD₁ does have reflex connections onto motor neurones serving muscles other than those involved in movement of the BI.

It has not proved possible to record from CSD₁ in a freely moving animal, but mimicking limb movement by pulling on the AL tendon of an unclamped limb shows that free movement, both levation and depression, of the limb about the coxa-BI joint elicits no distinct response from

CSD₁ (Fig. 34b), until the limb meets an external resistance which prevents levation so that AL muscle contraction moves from isotonic towards an isometric state and CSD₁ units are then stimulated (Fig. 34c). CSD₁ is therefore unlikely to be responsive to the contractions of the AL muscle which normally levate the limb, but rather signals when such levation is resisted (Fig. 34c). If AL muscle contraction continues, CSD₁ can then prevent accidental autotomy resulting from excess AL tension by reflexly inhibiting AL motor activity (Figs. 30, 31, 32).

DISCUSSION

The specialisation of the BI cuticle to provide a fracture plane allowing the clean separation of the peripheral limb from the retained BI stump builds an inherent weakness into the limb. This is not a structural weakness, since Fredericq (1892) showed that when the limb was subjected to large tensile stresses it was one of the limb's joints which separated and not the breakage plane. The crab uses the forces generated by contraction of the AL muscle to cause autotomy and also to levate the limb during normal locomotion and thus contains a mechanical fault which must be protected from accidental and unintentional strains. The evidence which is presented here can be used to explain how the BI muscles are organised to cause autotomy in the appropriate circumstances and to prevent it when not required.

This hypothesis, as were those of McVean (1973, 1974) and Moffett (1975), is based upon a number of mechanical assumptions. The first, is that since the plug in the breakage plane is an intact cuticular connection and not just a deflection of the preformed breakage plane (McVean, 1973, Moffett, 1975), force exerted by the AL muscle must be concentrated onto this point in order to fracture the cuticle before separation can spread around the breakage plane. The second assumption is really the obverse of the first, that is, since the AL muscle also provides the

force to levate the limb during normal locomotion, it must be directed away from the crucial regions of the BI so that autotomy will not occur accidentally in inappropriate circumstances.

It was explained earlier how this bi-functional nature of the AL muscle was not just a matter of the degree of force exerted by the muscle onto the BI in different circumstances (McVean, 1974). The PL muscle, which must, presumably, once have been a "normal" muscle acting as a levatory synergist with the AL muscle, provides a simple device which can differentiate the effects that the AL muscle has upon the BI. The PL tendon of Pagurus and the RPL tendon of Carcinus both provide little if any levatory support to the limb, but instead, influence the position of the AL tendon head (Figs. 17, 18) and thus the deployment of force generated by AL muscle contraction upon the BI. Two alternative possibilities detailing how the position of the PL tendon and the AL tendon head might influence the deployment of AL muscle force were outlined earlier (Figs. 17, 18). It has not proved possible to build a satisfactory model of the BI to test these mechanical possibilities or the efficiency of AL force deployment onto the BI. Therefore the interpretation of the mechanical events which lead, first, to autotomy, and then obversely to it's avoidance, must rely upon the behaviour of the muscles involved in the different circumstances.

McVean (1973, 1974) believed that the AL tendon head

was fused to the BI, and would only rotate when a breakage plane in the tendon head was fractured by rotation of the PL tendon. The tendon head was to remain fused to the BI during normal activity, but fractured by PL rotation to cause autotomy by directing AL force onto the plug. Moffett (1975) showed that the AL tendon head is never fused to the BI, but instead, ventral projections from each, fit closely together, and are opened or closed by the relative positions of the PL tendon blade. This investigation confirms Moffett's (1975) observation in Cardisoma, the AL tendon heads in Pagurus (Fig. 17) and Carcinus (Fig. 18) are not fused to the BI, but instead freely articulate upon movement of the PL tendon in Pagurus (Fig. 12a) and RPL tendon in Carcinus (Fig. 13a,b). Fig. 24a,b shows that when injury is caused to the peripheral limb, it not only stimulates activity in the AL muscle, but also before autotomy, the fast PL unit fires. Therefore, prior to autotomy, the PL tendon will rotate (Figs. 21b, 22b) and open the abutting faces between the AL tendon head and the BI (Figs. 17, 18). With the AL tendon head in this position therefore, the AL force must be concentrated onto the plug to achieve autotomy (Fig. 26b). Such activity in the PL muscles of Pagurus and Carcinus before autotomy, contradict the hypothesis suggested by Moffett (1975), where the PL muscle was inhibited and where AL force was supposed to be directed onto the plug when the abutting faces between tendon head and the BI are closed.

Moffett (1975) instead suggested that the PL tendon would be rotated during normal locomotion, rotating in turn the AL tendon head and spreading AL's force around the dorsal BI. This suggestion was based upon the evidence of Clarac & Wales (1970) and Clarac & Coulmance (1971), where electrical activity, recorded from the PL muscle during normal locomotion, was interpreted as resulting from activity of the fast PL unit.

Both McVean (1973, 1974) and Moffett (1975) recorded the activity of the BI levators when the peripheral limb was injured leading to autotomy, and interpreted the mechanical events causing cuticular fracture on the basis of the motor activity observed. They then assumed that since autotomy must be achieved by their interpretation of that part of the mechanical events, that the opposite alternative must hold true for normal locomotion and possible autotomy avoidance (McVean, 1973, 1974, Moffett, 1975). Neither recorded from the crucial PL muscle during normal locomotion. Such recording in this investigation (Fig. 25c,d,e) reveals that it is the slow PL unit which provides the electrical activity seen in the PL muscles of Pagurus and Carcinus and not the fast unit as was suggested by Clarac & Wales (1970), so that the PL tendons will not rotate (Figs. 21a; 22a) and the AL tendon head will be held flush against the BI during normal locomotion (Fig. 26a).

The division of the AL muscle insertion (Figs. 12a;

13a) and the influence of the PL tendon upon the deployment of force through the AL tendon head (Fig. 17) are thus shown to differentiate normal locomotion from autotomy. Force is concentrated onto the plug in the breakage plane when the abutting faces between the AL tendon head and the BI are separated by PL tendon rotation (Figs. 24a,b, 26b) and directed away from the critical area of the BI during normal locomotion when the PL muscle, although excited by one of its motor axons does not rotate (Figs. 21a; 22a; 25c,d,e) so that the AL tendon head is held flush against the BI (Fig. 26a).

Although their interpretations of the mechanical events and thus nervous recruitment of the muscles involved in causing autotomy differ, McVean (1974) and Moffett (1975) agree when they suggest that the nervous control of the BI levator muscles results solely from the central nervous system's response to sufficient injury of the peripheral limb. Both authors isolated the central nervous response to injury by preventing injury induced contractions of the AL muscle from acting upon the BI. Thus McVean (1974) stated that peripheral injury could stimulate the fast PL unit and cause PL tendon rotation. Moffett (1975), on the other hand, found that PL units were inhibited by injury to the peripheral limb. The results obtained here, when the central nervous response to injury is isolated (Fig. 28a,c), fall closer to those

obtained by Moffett (1975) than those by McVean (1974). PL units being inhibited for the greater part of the CNS response to injury (Fig. 28a,c).

The sense organ CSD₁ is ideally situated to monitor strains imposed by the AL muscle upon the critical portion of the BI (Wales et al., 1970; Wales et al., 1971) and has ~~long~~ been thought to be involved in the nervous control of the BI muscles during both limb autotomy and its avoidance in inappropriate circumstances (Clarac & Wales, 1970; Clarac et al., 1971; Moffett, 1975; Clarac, 1976). CSD₁ and the reflex loop exciting the fast PL unit, are stimulated by strains exerted onto the BI by isometric contractions of the AL muscle (Figs. 20b,f, 29c; Clarac & Wales, 1970; Moffett, 1975), and this response is maintained when such tension causes artificial fracture of the breakage plane (Fig. 29a,c,d; Moffett, 1975). Moffett (1975) suggested that this reflex was inhibited by injury of the limb since it was absent from her records of autotomy. The results obtained here, however, show that activity of the fast PL unit, stimulated by AL tension, is not inhibited upon injury of the peripheral limb (Figs. 33c, 34a). It is therefore suggested that the fast PL unit activity observed in the PL muscles of Pagurus and Carcinus just prior to limb autotomy (Fig. 24a,b) results from activation of the CSD₁-PL reflex loop by the strong isometric contractions of the AL muscle caused by limb injury (Figs. 28a,c, 29c,d).

For the greater part of this thesis, the events which culminate in limb autotomy in the hermit crab Pagurus and the shore crab Carcinus have been treated as almost identical and with the exception of the addition of the PPL muscle in Carcinus, regarding the basic features of the anatomy and physiology of the BI and associated muscles, this is true. However, in the detailed role of the CSD₁ sense organ and the reflex loop exciting the fast PL unit, in directing injury induced AL tension onto the plug to cause autotomy, the two animals do differ.

In Pagurus, the central nervous response to injury involves, prior to their inhibition, the stimulation of both slow and fast PL units (Fig. 28c), and therefore AL force, simultaneously excited by injury (Fig. 28c), would be switched immediately onto the plug region of the breakage plane. Since the CSD₁-PL reflex has a lower threshold for excitation by the AL muscle when it's force is exerted onto the plug (Fig. 33a), PL tendon rotation is more easily maintained by the initial levels of tension in the AL muscle excited by injury (Fig. 33d), which in turn maintains that same AL force onto the plug until it is sufficient to cause cuticular fracture and limb autotomy.

In Carcinus, the fast PL unit is absent from the central nervous response to injury (Fig. 28a), and is not recruited in the intact animal until just before autotomy occurs (Fig. 24b). Attempts to stimulate the CSD₁-fast PL

unit reflex in dissected preparations revealed that the reflex loop is (only) excited when considerable tension has already been applied to the AL tendon (Fig. 20f). In fact, the CSD₁-PL reflex loop is not excited until the cuticular ridge distal to the anterior half of the AL tendon head (Figs. 13a, 18) is visibly distorted by the application of isometric tension to the AL tendon. If such tension is then released from the AL tendon, the ridge resumes its original shape, it could therefore act as an elastic energy store for isometric tension exerted by the AL muscle. Force exerted by the AL muscle, when stimulated by peripheral injury, has to distort this "energy store" (Fig. 35b) before the reflex loop onto the fast PL unit is excited, and would explain the relatively late recruitment of the fast PL unit prior to autotomy in the intact animal (Fig. 24b). Therefore the AL muscle will already be under considerable tension when it is switched onto the plug to cause cuticular fracture. An action which could be aided by shearing forces resulting from the recoil of the energy store and sudden rotation of the RPL tendon onto the already stressed AL tendon head (Fig. 26b).

The Young's Modulus and tensile strength of biological materials are usually measured when strains are imposed slowly (Alexander, 1968). When strains are imposed rapidly, there is evidence that some materials have a higher yield strength (Richards, 1961; Alexander, 1975), but at

Fig. 35 : Scanning electronmicrographs of the dorsal surface of the BI of walking limbs of Pagurus bernhardus and Carcinus maenas.

a. Anterior view (x 60) of the dorsal surface of the proximal BI segment of the third left pereiopod of Pagurus bernhardus showing the breakage plane, soft membrane overlying CSD_1 and the insertion of the AL tendon head. Note that the cuticle distal to the AL insertion slopes gently down towards the breakage plane.

b. Anterior view (x 24) of the dorsal surface of the proximal BI segment of the third right pereiopod of Carcinus maenas showing the breakage plane, the soft membrane overlying CSD_1 and the anterior part of the AL muscle insertion. This photograph was taken from approximately the same position as a. and shows that instead of sloping gently down to the breakage plane as in Pagurus (a.) the cuticle distal to the insertion of the AL muscle is raised above the level of the rest of the BI and then falls away abruptly towards the breakage plane. This is the energy store region (es) of the dorsal BI described in Figs. 6 and 15.

a.



b.

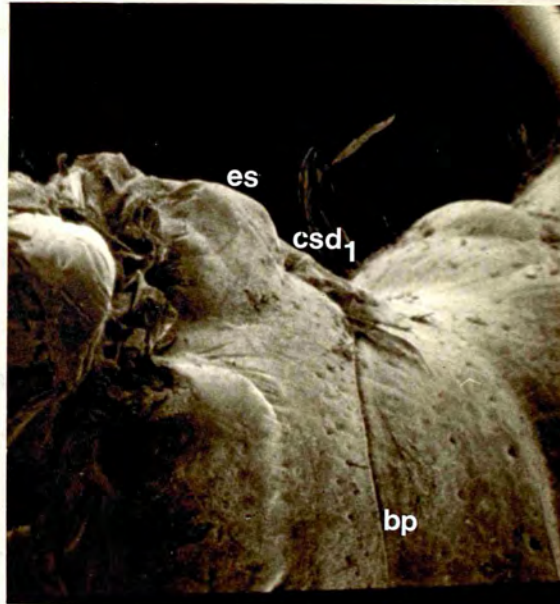

extremely high strain rates the strengths of materials may take a sudden drop (Richards, 1961). Carcinus could be taking advantage of this property to achieve fracture by imposing a strain shock onto the intact connection across the breakage plane.

A simple summary of the differences between the two species could state that where Pagurus pulls on the plug until AL tension is sufficient to achieve cuticular fracture, Carcinus springs the plug by suddenly switching accumulated AL tension from the energy store.

Part of this distinction, we have seen, derives from the different central nervous responses to injury of the two species (Fig. 28a,c). A careful examination of the structure of the BI in each species also reveals that in Carcinus the dorsal rim of the BI and the insertion of the AL muscle, are raised above the level of the rest of the BI (Fig. 35b), the region between the AL insertion and the breakage plane is also more sculptured than this area in Pagurus (Fig. 35a). These are fine structural differences which could also influence the way in which the soft membrane and sensory strand of CSD₁ are stimulated by strains imposed upon the BI by isometric contraction of the AL muscle.

The hypothesis, as it has been presented so far, involves strong isometric contractions of the AL muscle, stimulated by limb injury, being concentrated onto the

plug in the breakage plane by their reflex excitation of the fast PL unit through CSD_1 . Circumstances could arise where the contraction of AL could approach an isometric state and threaten the structural integrity of the breakage plane. If the limb was prevented from levating, strain would be exerted onto the BI by the AL muscle, stimulate CSD_1 (Figs. 20b, 34c), and in turn excite the fast PL unit, causing the AL force to be switched onto the plug. Accidental autotomy, in circumstances such as these, has to be avoided. It is an obvious disadvantage for the animal to autotomise it's limbs each time they met with a resistance to movement, which could occur if the reflex loops outlined above as causing autotomy were all that were present.

During normal locomotion, alternate levation and depression of the limb about the coxa-BI joint is under the control of central locomotor command (Clarac & Coulmance, 1971; Barnes et al., 1972; Burrows & Hoyle, 1973) causing synergistic bursts of firing from the two BI levators (Fig. 25b,c,d) and alternate, antagonistic firing in the BI depressor muscle (Fig. 25a,b,e).

The relatively isotonic contractions of the AL muscle during locomotion are unlikely to put much strain on the BI and thus do not elicit responses from CSD_1 (Fig. 34b). If limb levation is resisted by an external object, contraction of the AL muscle would move towards an isometric state and strain be exerted onto the BI,

stimulating CSD₁ (Fig. 34c). If contraction of the AL muscle continued, such strain might threaten the breakage plane. At this point CSD₁ responses cross a threshold and activate not only the reflex loop exciting the fast PL unit, but also inhibit AL motor units (Figs. 31, 32). The strain on the dorsal BI would be released and thus accidental autotomy prevented. Since CSD₁ inhibition on AL motor neurones is so long lasting, the inhibition may well work at lesser AL muscle tensions by reducing the frequency of AL motor unit firing rather than completely shutting them off.

Clarac (et al., 1971, 1976) and Moffett (1975) suggested that autotomy could be prevented when excess AL muscle tension, via CSD₁, causes the PL tendon to rotate, to spread the strain around the dorsal rim of the BI and assuming some of that load itself. Although the PPL muscle of Carcinus could assume some load (Figs. 13a,b, 27), Moffett (1975) showed that rotation of PL tendon in Cardisoma did not lead to stress lines appearing in the membrane connecting the tendon with the BI, and the PL muscle could not contribute to active limb levation. Both authors, however, also indicated that stimulation of the fast PL unit by CSD₁, simultaneously excited AL motor units (Clarac et al., 1971, Moffett, 1975, Clarac, 1976), so that excess strain exerted by the AL muscle which is threatening to cause accidental autotomy, would stimulate even gr^eater tension by a positive feedback loop from CSD₁. A more satisfactory manner for the avoidance

of accidental autotomy when AL tension is too great in such inappropriate circumstances would be for CSD₁ to activate a negative feedback loop onto AL motor units (Figs. 31, 32) to reduce the strain imposed by them on the BI as outlined here.

To cause autotomy, however, such inhibition of AL units by CSD₁ has to be avoided, isometric contractions of the AL muscle are required to cause cuticular fracture (Fig. 24a,b). Although normally such strain imposed upon the BI by the AL muscle would reflexly inhibit AL activity (Figs. 31, 32), when the fast PL unit is excited by AL tension stimulating CSD₁, AL motor unit activity is still stimulated by injury of the peripheral limb (Fig. 34a).

How injury stimulates firing of the AL units to avoid CSD₁ induced inhibition remains to be determined, although two possibilities suggest themselves. Crushing the peripheral limb excites large numbers of sensory and motor fibres contained within the main nerve trunks of the limb, these fibres send impulses into the central nervous system and generate the central nervous response to injury, involving the high frequency firing of AL motor units (Fig. 28). The high level of excitatory synaptic input to AL motor neurones could over-ride CSD₁ induced ijp's on the same motor neurones. Or since 21 axons supply the AL muscle of the fifth pereopod of Carcinus (McVean, 1974) and in Pagurus, up to 16 motor

neurones have been filled by cobalt iontophoresis of the AL nerve of the third left pereopod (Fig. 14), and usually only three physiological units are recorded from the AL nerves of both species (Fig. 19, McVean, 1974), a number of AL motor neurones could be reserved for excitation by injury and not influenced by CSD₁ inhibition. The resolution of this question will require an intracellular examination of the reflex and injury pathways within the central nervous system.

GENERAL DISCUSSION

The mechanism of limb autotomy outlined in this study is essentially that proposed by McVean (1970, 1973), relying upon coactivation of the two BI levator muscles to direct and concentrate the force exerted by the AL muscle onto the plug connection in the breakage plane. A similar hypothesis was first put forward by Paul (1915) who suggested that coactivation of the two BI levators in Homarus would prise apart the furrow which now bears his name, and thus initiate the fracture of the breakage plane on the dorsal surface of the BI. Such a mechanical effect may be caused by rotation of the RPL tendon in Carcinus against the already strained AL tendon head, but it is not thought to form the main part of the initiation of fracture of the cuticle plug. Instead, the concentration of AL force onto this small cross-sectional area of cuticle was calculated by McVean (1973) to be more than sufficient to cause fracture, even more so should the connection be subjected to a strain shock (Richards, 1961).

The AL muscle has been accepted as providing the force necessary to cause autotomy ever since Fredericq (1883, 1892) showed that pulling on the AL tendon blade when the peripheral limb is unable to move, can artificially induce fracture of the breakage plane. This observation has often been repeated (Paul, 1915, Wood & Wood, 1932, McVean, 1973, Moffett, 1975), and confirmed by muscle

ablation experiments which indicate that as long as the AL muscle is intact autotomy will occur (Wood & Wood, 1932, Moffett, 1973). Such ablation evidence led both Wood & Wood (1932) and Moffett (1975) to suggest that the AL muscle acted alone to cause autotomy. Wood & Wood (1932) proposed that the AL muscle was reserved to cause autotomy, the PL muscle levating the limb during normal locomotion, but repeating their experiments on Carcinus showed that the AL muscle is involved in the normal levation of the limb, which is confirmed by electrical activity recorded from the AL muscle during locomotion (Fig. 25).

Moffett (1973, 1975) also showed the AL muscle of Cardisoma to be active during normal locomotion, but she was unable to record from the PL muscle in similar circumstances. Instead, she relied upon the records of PL activity during locomotion provided by Clarac & Coulmance (1971). Moffett's (1975) hypothesis for the solo action of the AL muscle to cause autotomy is opposed by the records of muscle activity causing autotomy obtained during this investigation (Fig. 24).

The crucial point upon which was based the differences between McVean (1973, 1974) and Moffett (1975) was the activity and role of the PL muscle. This investigation has shown that electrical activity may be recorded from the PL muscle during both normal locomotion and limb autotomy (Figs. 24, 25), but that the effect of this electrical activity depended upon which of the two PL

motor neurones was firing at a given time (Figs. 21a,b, 22a,b). In Carcinus, the anatomical division of the PL muscle into two parts (Fig. 13) was initially thought to settle these differences. Subsequent investigation, revealed instead, that the separate physiological and mechanical effects of the two PL motor neurones on their muscle fibres (Figs. 21, 22, 23), aided by the anatomical gradation of their innervation in the PL muscle of Pagurus and RPL muscle of Carcinus (Table 8), are responsible for the differentiation of function of the two PL motor neurones.

The separate effects of the two PL motor neurones decide the distribution of the force exerted by the AL muscle in Carcinus and Pagurus, distinguishing between the mechanical requirements for normal limb levation and limb autotomy (Fig. 26). The events support the hypothesis which was outlined earlier, and is subtler than either of the two opposing suggestions of McVean (1973, 1974) and Moffett (1975). Autotomy is not just caused by the AL muscle providing more force than during locomotion, a point demonstrated by McVean (1973), it is not usually caused by the AL muscle alone as suggested by Wood & Wood (1932) and Moffett (1975), it is caused by coactivation of the two BI levator muscles (Fig. 24, Paul, 1915, McVean, 1973, 1974), but the PL muscle is also active during normal limb levation (Fig. 25, Clarac & Wales, 1970, Clarac & Coulmance, 1971, MacMillan, 1975, Ayers & Davis, 1977a).

The hypothesis of the mechanical events causing autotomy, and the nervous control of the muscles involved, described here, is complex. Yet the PL muscle, and thus the CSD₁-PL reflex and the influence it has on the direction of AL muscle force (Fig. 26) can be removed and autotomy will still occur (Wood & Wood, 1932; Moffett, 1975, personal observation). This contradiction can be best explained in terms of the development of the autotomy mechanism and reflex through the Crustacea.

It seems probable that at some time in the evolutionary development of decapod crustaceans the PL muscle tendon pointed axially in the limb and the muscle supported part of the limb load during locomotion. In macruran crustaceans such as Homarus, the PL muscle tendon does not hang perpendicularly into the limb, but projects more acutely from the dorsal rim of the basipodite. In macrurans, the chelipeds are able to autotomise, as in brachyurans, the basipodite and ischiopodite segments of the cheliped are fused and the breakage plane completely encircles the limb. In the walking legs of Homarus, however, the basipodite and ischiopodite are separate and the breakage plane is incomplete. It only runs around the dorsal surface of the ischiopodite and ends on the anterior and posterior faces of the B-I joint. Complete separation of the peripheral limb is only achieved when the ventral portion of this limb joint is torn apart (Wood & Wood, 1932; Wales et al., 1971). Therefore the actions of the two BI levator muscles,

and in this case possibly also the ischiopodite remotor muscle (Wales et al., 1971), do not lead to the total loss of the peripheral limb, only separation of the dorsal part of the breakage plane. Another agent is required before the limb is fully separated from the animal. Wood & Wood (1932) introduced two terms, "autospasy and autotilly", to define this process of incomplete autotomy. The first describes the process by which separation is completed by an outside agent, the second for circumstances in which the animal itself tears off the limb. These two inelegant categories ignore the point that functionally they are identical, and as such it is proposed to ignore them and retain autotomy as an umbrella term.

While at the laboratory of the Marine Biological Association in Plymouth, a single specimen of Homarus gammarus was examined. Complete autotomy of the chelipeds was easily evoked once sufficient damage has been inflicted to the limb, and myogram records indicated that both the BI levator muscles were active up to fracture. Although the response of the AL muscle in the walking legs to injury of the limb was easily and repeatedly evoked, the response from the PL muscle was not conclusively determined and fracture of the breakage plane did not occur. Tension applied to the AL tendon eventually resulted in cuticular fracture, but only as far as the ventral B-I articulation. The AL muscle provides the force to initiate limb autotomy but is little influenced by the PL muscle. The AL tendon head is not as well developed as in brachyurans and

movement of the PL tendon does not influence the tendon head of the AL muscle as much.

In walking legs and chelipeds of the hermit crab Pagurus bernhardus (Anomura), the PL tendon hangs perpendicularly from the BI, rotation of the tendon influences the orientation of the AL tendon head (Figs. 12a,b, 17), the basiopodite and ischiopodite segments of the limb are fused, and the breakage plane completely encircles the limb. Autotomy involves coactivation of the BI levator muscles (Fig. 24a), the AL muscle by central nervous response to injury (Fig. 28c), the PL muscle by reflex excitation via CSD₁ (Figs. 29c, 33c). The AL force is, however, switched almost immediately onto the plug in the breakage plane, and must maintain and increase strain on this portion of cuticle until fracture occurs (Figs. 24a, 33a,b,d).

In the brachyuran crab Carcinus maenas, with the exception of the addition of the PPL muscle (Fig. 13), the anatomy of the BI and levator muscles is similar to Pagurus. Functionally, the tension developed by the AL muscle on injury to the limb, is allowed to build up before it is rapidly switched onto the plug in the breakage plane (Figs. 24b, 34a).

In these three crustaceans, taken from three groups that are generally regarded to be in ascending evolutionary order, we can see the development and sophistication of the autotomy reflex. The function of the AL muscle remains relatively constant, levating the limb during walking and

also providing the force to cause fracture of the breakage plane. The function of the PL muscle, however, changes. In Homarus it probably provides some force for levation of the limb, in Pagurus, PL can provide little if any levatory support and in Carcinus, and other brachyurans, PL is subdivided so that a part of the muscle has the sole function of aiding limb levation.

The role of the PL muscle in Pagurus and RPL in Carcinus is the same, to alter the orientation of the AL tendon head and thus the direction of AL force (Figs. 17, 18, 26). The nervous control of the muscle and especially the fast PL motor neurone has undergone some sophistication. In Pagurus it is organised in such a way as to aid extraction of the plug, while in Carcinus it's action is such that the cuticular plug is rapidly snapped.

The role of the PL muscle and the CSD_1 reflex loop have developed, it is suggested, to increase the ease with which autotomy can be achieved, an achievement which does not increase the chance of limb loss in the wrong circumstances, but makes the event more certain and more rapid when it is required. From here, it is a small step to envisage the volitional elements of "attack autotomy" (Robinson et al., 1970).

The sense organ CSD_1 is sensitive primarily to strains exerted onto the cuticle of the dorsal BI by contraction of the AL muscle (Fig. 20a,b,c,d, Clarac et al.,

1971, Moffett, 1975, Clarac, 1976). It has reflex connections to the motor neurones controlling the BI muscles (Figs. 20e,f, 29, 30, 31, 32) and also to muscles peripheral in the limb (Clarac, 1976). Connections from sense organs to muscles controlling other limb segments were described as "centripetal" by Moody (1970, 1972) and "distributed" by Vedel et al., (1975) and Ayers & Davis (1977b). The CB chordotonal organ also mediates the greater part of antennal compensatory movements in Palinurus (Clarac et al., 1976). These inter-segmental reflexes have been suggested by their respective investigators to function in the control of posture. In this study, the reflex loops from CSD₁ to the BI musculature have been shown to operate only when considerable strain is exerted on the dorsal BI by the AL muscle (Figs. 20e,f, 29), whether the distributed reflex connections from this sense organ also require such a high threshold of stimulation has not been determined.

In recent years, a variety of sense organs have been described as responding to muscle tension, these include muscle apodeme sensory receptors on some crustacean muscles (MacMillan & Dando, 1972, Clarac & Dando, 1973, Dando & MacMillan, 1973), tail spine muscle receptors in Limulus (Eagles & Hartman, 1975), and campaniform sensillae in insects (Bowerman, 1977). A number of motor systems have also been shown to be modified by sensory input which arises from as yet unidentified tension sensors (Heitler & Burrows, 1977, MacMillan et al., 1976, Evoy &

Fourtner, 1973; Field, 1976; Vedel & Clarac, 1975).

These sense organs respond to isotonic (Dando & MacMillan, 1973) as well as isometric tension (MacMillan & Dando, 1972; Clarac & Dando, 1973; Eagles & Hartman, 1975) developed in the muscles on which they are situated, and they also give rise to reflex responses in certain muscle motor neurones. In Limulus tail spine muscles these reflex connections have not been identified (Eagles & Hartman, 1975). At the M-C joint of Cancer walking leg, mild stimulation of the apodeme sensory nerve inhibits activity in it's own effector muscle and may slightly increase activity in it's antagonist (Clarac & Dando, 1973), strong stimulation causes high frequency excitation of both muscles (Clarac & Dando, 1973). A series of tension receptors in the locust leg act to reinforce, via positive feedback, the coactivation of femur extensor and flexor muscles prior to defensive kicks (Heitler & Burrows, 1977). Strain exerted onto trochanteral campaniform sensillae in cockroach legs inhibits discharge of coxal levator motor neurones (Bowerman, 1977).

Other peripheral proprioceptive sense organs have been described which also limit motor activity and modify a central motor score. In cockroach locomotion the trochanteral hair plate limits femur flexion (Wong & Pearson, 1976; Pearson et al., 1976), similar sensory derived limitations of muscle activity are found in the masticatory systems of the snail (Kater & Rowell, 1973)

lobster (MacMillan et al., 1976), and in locust flight (Burrows, 1975).

CSD₁ is not, strictly speaking, a tension receptor. It is not directly associated with the apodeme or with muscle fibres of the AL muscle, and it does not respond to isotonic tension in the AL muscle (Fig. 34b). What it does respond to is cuticular strain, strain that usually results from strong isometric contractions of the AL muscle (Figs. 20b, 29a, 34c, Clarac et al., 1971; Moffett, 1975). Functionally, it is similar to the campaniform sensillae which respond to cuticular strain in insects (Pearson & Iles, 1973).

The reflex loop from CSD₁ which inhibits further AL contraction (Figs. 30, 31, 32) is another example of a sense organ acting to limit the activity of the ^{effector} muscle ~~which stimulates it~~, what is unusual, is that these type of sense organs usually also excite an antagonistic muscle (Clarac & Dando, 1973; Pearson et al., 1976; Wong & Pearson, 1976). In Pagurus, stimulation of CSD₁ will excite a single motor neurone supplying the BI DEP muscle (Fig. 20d), but in Carcinus no effect on the DEP muscle has been elicited by CSD₁ stimulation, while in both animals the synergistic PL muscle is reflexly excited (Figs. 20c,e,f, 29c,d,e, Clarac & Wales, 1970; Clarac et al., 1971; Moffett, 1975). Moffett (1975) suggested that this acted to direct excess AL force away from the breakage plane, but since AL is inhibited at the same time as PL is excited (Figs. 30, 31,

32), such a function is redundant. Instead, during autotomy, this reflex excitation of PL is used to direct AL force onto the breakage plane (Figs. 24, 26).

Positive feedback from a sense organ to its own excitor has been described by Heitler & Burrows (1977) in the locust leg, and by Clarac & Dando (1973) in the crab leg. In an interesting experiment Bassler (1976) showed that the resistance reflex from the femoral chordotonal organ in the stick insect Carausius is reversed in an "active" animal, when the CNS is in a state of high excitability the normal negative feedback resistance reflex is reversed to give positive feedback onto the muscle causing the movement. This experiment has considerable importance when considering the role of such organs in normal locomotion. Most workers have concluded that resistance reflexes are centrally inhibited during normal activity and only act when normal movement is opposed (Barnes et al., 1972, Field, 1974, Vedel & Clarac, 1975, Ayers & Davis, 1977b). Bassler (1977), however, has also shown that although ablation of chordotonal organs from the legs of a stick insect do not unduly affect the stepping performance or the locomotor programmes recorded from the muscles, when the chordotonal organs were modified to provide incorrect afferent information during locomotion, walking was fundamentally affected.

The role of chordotonal organs during active limb and joint movements must be rethought in the face of this

evidence. The classic resistance reflex (Bush, 1965a, 1965b) may be used in the maintenance of posture as the above authors have suggested, but an increase in the excitability of the CNS during active movement could alter the reflex influence of chordotonal organ stimulation to endorse ongoing movement. These sense organs must be providing important sensory information to the CNS about leg and joint positions and velocities, and at the same time allowing in-cycle modification of the central motor score with respect to the animal's immediate environment.

Why autotomy? Why have some animals developed the ability to discard a part of their body? The phenomenon is found in widely separate phylogenetic groups of animals and only in decapod crustaceans and some groups of reptiles does there appear to be a gradation in the development of the ability to autotomise a part of the body.

Referring back to the General Introduction of this thesis, it can be seen that different animals have developed the ability to discard different parts of the body. All are able, to some extent, to regenerate these structures once autotomised, and so in no case is loss a permanent condition, except perhaps for the oldest individuals (Edwards, 1958; McVean, 1976). Even so, the loss of some structures, such as crustacean limbs (this study), walking limbs of other arthropods (reviewed by McVean, 1975), molluscan "feet"

and pallial tentacles (Fishelson & Kidron, 1968; Morton, 1973), starfish and brittlestar arms (King, 1898, 1900; Wilkie, cited in McVean, 1975), sea-cucumber guts (Swann, 1966; Smith & Greenberg, 1973) and some lizard tails (Pratt, 1946), must involve the animal in a "decision" between the possible impairment of normal function or ability and the danger from the autotomy inducing agent. The loss of other structures, such as salamander (Wake & Dresner, 1967; Maiorana, 1977), lizard (Pratt, 1946) and mouse tails (Layne, 1972), on the other hand, probably cause no impairment of the animal's normal abilities. Pratt (1946) noticed in lizard tails, that as they assume more definite and specialised functions, the ability to autotomise declines and is lost.

A gradual development and sophistication of the autotomy reflex in decapod Crustacea was outlined earlier. The only other groups to show a similar development of the ability to autotomise are the salamanders and lizards. Wake & Dresner (1967), studying tail autotomy in a variety of salamanders, describe and review a number of species which differ in the ease by which they can lose their tails. These range from a reaction of extreme agitation when the tail is held so that it appears to be torn off, to situations in which a light grasp of the tail is sufficient. Examining the incidence of tail autotomy in these species, Wake & Dresner (1967) did not find an increased occurrence of autotomy in the more "advanced"

species and concluded that anatomical specialisation had developed to control tail autotomy rather than to cause it per se. A similar conclusion has been reached by the author with regard to the development of the limb autotomy reflex in the decapod Crustacea.

Another classification of the occurrence of autotomy in different phylogenetic groups can be made upon the basis of what appears to be the function and circumstances leading to the loss of part of the body. Escape from the grasp of a predator has obvious advantages and could be the sole reason for the autotomy of tails in mice (Layne, 1972), lizards (Pratt, 1946) and salamanders (Wake & Dresner, 1967), for the loss of arms by echinoderms (King, 1898, 1900; Delage & Herouard, 1903; Wilkie, cited in McVean, 1975), mollusc "feet" (Fishelson & Kidron, 1968), and in some cases the loss of arthropod limbs. A proportion of the limb autotomies in Carcinus caught in the Yealm estuary probably occur to allow the crab to escape the grasp of either another crab or a predator. Other examples seem less directed towards escape from predators but more to deter them, the pallial tentacles of Galeomma and other bivalves are thought to secrete noxious substances (Morton, 1973), and gut eversion by sea-cucumbers could also distract a potential predator (Swann, 1966; Smith & Greenberg, 1973).

In the arthropods, other reasons may have played a part in the development of autotomy. Damage inflicted to

the limbs by the environment could lead to the impairment of function, and also possibly bleeding to death of the animal. Paul (1915) and McVean (1976) cite damage inflicted by the environment as causing a significant proportion of the limb autotomies they observed in natural populations of Carcinus. In this study the high incidence of autotomy in Carcinus caught in the lower reaches of the Yealm estuary (Fig. 4a) may also result from damage caused by the movement of stones and boulders. Limb autotomy in such circumstances allows for the limb to be replaced by a fully functional regenerate. When lost, the BI stump is sealed and thus blood (Fredericq, 1892; Paul, 1914) and metabolite losses (Raja et al., 1976) are prevented.

ACKNOWLEDGEMENTS

I would like to express my gratitude to Dr. Alistair McVean for his encouragement and supervision of this work.

I am indebted to the Director and staff of the laboratory of the Marine Biological Association (U.K.), Plymouth for providing space and facilities between January 1976 and February 1977, and also to Mr. Tony Maskell for allowing me to store the dinghy and trapping equipment on his premises at Steer Point on the Yealm estuary.

I would also like to thank Mr. Z. Podhorodecki who assisted in the preparation of the figures and Mrs. L. Rolphe who assisted with the scanning electronmicroscopy shown in Fig. 35.

This work was supported by an S.R.C. grant awarded to Dr. A.R. McVean.

APPENDIX 1 : AXONAL IONTOPHORESIS OF COBALT CHLORIDE

INTRODUCTION

The technique of intracellular staining was first developed for intracellular micro-iontophoretic injection of dye into neurone somata to enable the anatomical identification and structural examination of the projections of single neural units within the central nervous system (see Kater & Nicholson, 1973, for reviews of early work). A less selective technique was introduced by Iles & Mulloney (1971) to introduce dye into the central projections of neurones by backfilling from their peripheral axons. The number of units filled by this technique depends upon the number of axons contained within the particular nerve trunk chosen, and if necessary the number can be reduced by splitting the trunk (Altman & Tyrer, 1974; Tyrer & Altman, 1974). Axonal iontophoresis, as developed by Iles & Mulloney (1971) became more widely used once cobalt chloride was introduced as an intracellular marker (Pitman *et al.*, 1972) and until recently Iles & Mulloney's (1971) was the basic technique used to introduce cobalt to the central nervous system. Simply, it consists of two chambers connected by a narrow channel. The piece of CNS is placed in one chamber and bathed in a suitable saline while the nerve trunk containing the axons to be backfilled is draped across a connecting channel into a second chamber and placed onto a pool of cobalt solution. Early attempts provided an electrical bias across the two

chambers, and although necessary for the transport of Procion dyes, it is not normally required for the iontophoresis of cobalt. The apparatus is left for the dye to pass centripedially up the axons towards the CNS.

APPARATUS

In this investigation, after much trial and error, the most effective apparatus was found to consist of two chambers cut in a wax base. These were constructed by melting wax in a crystallising dish, inserting two steel rods into the molten wax, then bringing the rods together so they were separated by a thin layer of wax, and holding them in place until the wax had hardened. When removed, the two rods left two chambers separated by a thin wall. A channel was then cut between the chambers with a sharp scalpel and in this way the channel could be 1 mm or less in length.

TECHNIQUE

The entire thoracic ganglion of Pagurus bernhardus and the nerve trunk required for iontophoresis were dissected rapidly from the animal and washed in saline, blood vessels and unwanted nerve trunks were trimmed close to the ganglion. The isolated tissue was placed into one chamber of the iontophoresis bath and covered with saline. The connecting channel was lined with vaseline and the

nerve trunk draped across into the second chamber. The channel was then sealed with more vaseline. A small pool of cobalt chloride solution (400 mM in distilled water) was pipetted into the second chamber and the nerve trunk placed into it. The whole dish would then be covered to prevent evaporation and incubated at 10°C for 18-24 hours.

After incubation, the nerve trunk was severed on the ganglion side of the channel to prevent the leakage of cobalt when the ganglion was lifted from the bath. The ganglion was then washed in fresh saline and placed into a solution of 0.1 ml ammonium sulphide and 10 ml saline for 15 minutes to deposit the cobalt chloride as a black cobalt sulphide precipitate. This treatment is necessary since cobalt chloride is not itself visible within nervous tissue. The ganglion was then again washed in fresh saline, this time to remove excess sulphide from its surface and fixed in Alcoholic Bouin for one hour. The tissue was further dehydrated in 90% and 100% alcohol and placed in reagent grade creosote to clear.

The best results were obtained when the tissue was allowed to remain in creosote for at least a week and then examined as whole mount in creosote. They were photographed under a Nikon tri-nocular photomicroscope and drawn with a Wild drawing tube.

Reagent grade creosote (BDH supplies) was used as clearing agent since xylene, toluene and methylbenzoate were unable to completely clear the whole mount ganglion,

while creosote resulted in the nervous tissue becoming almost transparent leaving the black cobalt filled profiles in high relief. Although creosote was used for whole mounts it is not satisfactory for preparations which are to be sectioned as creosote is not miscible with paraffin wax. It causes the tissue block to shrink and wax will not properly impregnate the tissue, so when the material is to be sectioned another clearing agent must be used.

Several specimens were selected for preservation as permanent whole mounts, they were impregnated and mounted in DPX, but did not survive for more than 3-4 months. Gradually the sharpness of the profiles was lost, and as the whole tissue assumed a reddish tinge the filled profiles eventually disappeared. In tissue kept in creosote the process takes 2-3 weeks, with a slight extension if kept refrigerated. The cobalt sulphide precipitate probably gradually diffuses out of the cells into the surrounding tissue.

There are several variables within the procedure outlined above which must be taken into account when applying this technique to other animals. One is the concentration of cobalt chloride solution. The concentration used here (400 mM) was arrived at empirically. In early experiments various concentrations were used and 400mM appeared to give optimum intensity fills. Lower concentrations revealed neurone outlines faintly, and

stronger concentrations tended to obscure the ganglion by travelling up extra-axonal spaces within the nerve trunks. Extra-axonal transport is enhanced when an electric bias is applied to the preparation.

Another factor which must be determined carefully when using this technique is the time allowed for the dye to pass centrally and completely fill the neurones. When using isolated pieces of nervous system, as in this study, the problem is to balance the time taken to achieve a complete fill while preventing autolytic digestion of the tissue. A suitable ionic and osmotic environment must be provided for the isolated nervous tissue. The ionic environment is provided by using a known reliable saline for the species concerned, and osmotic balance by adding a small quantity of albumin to the saline. Even with a suitable saline, however, autolytic digestion can disrupt ganglionic structure before a good cobalt fill is achieved. Digestion can be delayed by incubating the tissue at low temperatures. At room temperature (approximately 20°C) isolated Pagurus and Carcinus tissues will not last longer than a couple of hours, at 10°C up to 30 hours incubation is possible before serious degeneration is visible, and at approximately 1°C it is possible to hold the tissue for up to 48 hours. However, the lower the temperature, the longer it takes the cobalt to migrate so that a suitable balance has to be achieved.

These variables have to be determined for each type

of preparation and several externally visible indicators of disintegration can be used to develop the optimum technique. The first of these is the external appearance of the ganglion after incubation, if it is swollen and opaque, it should be discarded, a good preparation should appear as it does in the animal, ie. not swollen and with transparent areas in the ganglion surrounding the opaque neuropilar regions. Once the cobalt has been deposited as black precipitate, several signs indicate the beginning of autolytic digestion. One is excessive "blobbing" of axon projections which is easily distinguished from real alterations in the diameter of projections. The other is discolouration of the tissue around black profiles which results from cobalt diffusing across the axon membrane. Any preparations showing such signs should be interpreted with care.

DISCUSSION

Recent advances have taken the power of axonal iontophoresis of cobalt as a neuroanatomical tool several stages further than described here. One is a method of improving the viability of the technique and is unfortunately not applicable to an examination of the thoracic nervous systems of crustaceans such as Pagurus and Carcinus, since it relies upon the use of "live" whole animals. It has been developed using insects where it has proved possible to dissect the animal and isolate parts of the nervous

system, while the animal at least continues to respire. This prevents the greater part of autolytic digestion and allows long incubation times at temperatures suitable for the animal (Kater & Nicholson, 1973; Strausfeld & Obermayer, 1976).

A recent development which is applicable to all cobalt filled nervous tissue is a modification of the Timm's sulphide-silver technique developed by Tyrer & Bell (1974). Tyrer & Bell's (1974) technique involves the replacement of cobalt in tissue sections with silver granules which do not diffuse out of the filled profiles as readily as cobalt. The technique also intensifies nerve profiles which contain only a very low concentration of cobalt, and thus previously invisible or indistinctly filled projections are revealed (Tyrer & Bell, 1974).

Strausfeld & Obermayer (1976) have modified this intensification method so that it is now applicable to tissue in whole mount. When they applied block intensification to cobalt fills of neurones of the fly optic lobe which had been incubated for long periods at low temperatures, Strausfeld & Obermayer (1976) found that the cobalt had migrated across synaptic connections to reveal several orders of interconnected neurones. This is a new and powerful aspect of the technique of intracellular staining as a means of examining now not only the structure and arborizations of particular neurones but also their connections with other neurones within the central nervous

system. In this study, although low temperature, long incubation periods were used, tissue blocks were not intensified as shown by Strausfeld & Obermayer (1976) and obvious cases of cross-synaptic migration of cobalt were not observed.

BIBLIOGRAPHY

- Alexander, R.McN. (1968) "Animal mechanics" Sidgwich & Jackson. London.
- Alexander, R.McN. (1975) "Biomechanics" Chapman & Hall. London.
- Alexandrowicz, J.S. & Whitear, M. (1957) Receptor elements in the coxal region of decapod Crustacea. J. Mar. Biol. Ass. U.K. 36, 603-628.
- Altman, J.S. & Tyrer, N.M. (1974) Insect flight as a system for the study of the development of neuronal connections. In "The experimental analysis of insect behaviour" L. Barton Browne (Ed.), Springer-Verlag. Berlin. pp. 157-179.
- Atwood, H.L. (1973) Crustacean motor units. In "Control of posture and locomotion" Stein, R.B., Pearson, K.G., Smith, R.S. & Redford, J.B. (Editors), Plenum Press (Advances in Behavioural Biology, Vol. 7). pp. 87-104.
- Atwood, H.L. & Walcott, B. (1965) Recording of electrical activity and movement from legs of walking crabs. Can. J. Zool. 43, 657-665.
- Ayers, J.L.Jr. & Davis, W.J. (1977a) Neuronal control of locomotion in the lobster, Homarus americanus. I. Motor programs for forward and backward walking. J. comp. Physiol. 115, 1-27.

- Ayers, J.L.Jr. & Davis, W.J. (1977b) Neuronal control of locomotion in the lobster, Homarus americanus.
II. Types of walking leg reflexes. J. comp. Physiol. 115, 29-46.
- Barnes, W.J.P., Spirito, C.P. & Evoy, W.H. (1972)
Nervous control of walking in the crab, Cardisoma guanhumi. II. Role of resistance reflexes in walking. Z. vergl. Physiol. 76, 16-31.
- Bassler, U. (1976) Reversal of a reflex to a single motoneuron in stick insect, Carausius morosus. Biöl. Cybernetics 24, 47-50.
- Bassler, U. (1977) Sensory control of leg movement in stick insect, Carausius morosus. Biol. Cybernetics 25, 61-72.
- Bauer, K.H. (1972) Funktionmechanismus de autotomie bei spinnem (Araneae) und seine morphologischen voraussetzungen. Z. Morph. Okol. Tiere 72, 173-202.
- Bliss, D.E. (1961) Autotomy and regeneration. In "Physiology of Crustacea, Vol. 1." Waterman, T.H. (Ed.), Academic Press. London & New York. pp. 561-589.
- Bowerman, R.F. (1977) The control of arthropod walking. Comp. Biochem. Physiol. 56A, 231-247.
- Broekhuysen, G.J. (1936) On development, growth, and distribution of Carcinides maenas. Arch. Neerl. Zool. 2, 257-399.

- Burrows, M. (1975) Monosynaptic connexions between wing stretch receptors and flight motoneurons of the locust. J. exp. Biol. 62, 189-219.
- Burrows, M. & Hoyle, G. (1973) The mechanism of rapid running in the ghost crab, Ocypode ceratophthalma. J. exp. Biol. 58, 327-349.
- Bush, B.M.H. (1965a) Proprioception by the coxo-basal chordotonal organ, CB, in legs of the crab, Carcinus maenas. J. exp. Biol. 42, 285-297.
- Bush, B.M.H. (1965b) Leg reflexes from chordotonal organs in the crab, Carcinus maenas. Comp. Biochem. Physiol. 15, 567-587.
- Carlisle, D.B. (1957) On the hormonal inhibition of moulting in decapod Crustacea. II. The terminal anecdyesis of crabs. J. mar. biol. Ass. U.K. 36, 291-307.
- Chapple, W.D. (1973) Role of the abdomen in the regulation of shell position in the hermit crab Pagurus pollicarus. J. comp. Physiol. 82, 317-332.
- Clarac, F. (1976) Crustacean cuticular stress detectors. In "Structure and function of proprioceptors in the invertebrates" Mill, P.J. (Ed.), Chapman & Hall. London. pp. 299-321.
- Clarac & Coulmance, M. (1971) Le marche laterale du crabe (Carcinus) : Co-ordination des mouvements articulaires et regulation proprioceptive, Z. vergl. Physiol. 73, 408-438.

- Clarac, F. & Dando, M.R. (1973) Tension receptor reflexes in the walking legs of the crab, Cancer pagurus. Nature (Lond.) 243, 94-95.
- Clarac, F., Neil, D.M. & Vedel, J.P. (1976) Control of antennal movements by leg proprioceptors in rock lobster, Palinurus vulgaris. J. comp. Physiol. 107, 275-292.
- Clarac, F. & Wales, W. (1970) Controle sensorial des muscles elevateurs au cours de la marche et de l'autotomie chez certains crustaces decapodes. C.R. Acad. Sci. Paris 271, 2163-2166.
- Clarac, F., Wales, W. & Laverack, M.S. (1971) Stress detection at the autotomy plane in the Decapod Crustacea. II. The function of receptors associated with the cuticle of the basi-ischiopodite. Z. vergl. Physiol. 73, 357-382.
- Dando, M.R. & MacMillan, D.L. (1973) Tendon organs and tendon organ reflexes in decapod Crustacea. J. Physiol. (Lond.) 234, 52-53P.
- Delage, Y. & Herouard, E. (1903) Les Echinodermes, Tome III. Traite de zoologie concrete. Schleicher. Paris.
- Demeusey, N. (1958) Recherches sur la mue de puberte du Decapode Brachyoure Carcinus maenas Linne. Archs. Zool. exp. gen. 95, 253-492.
- Eagles, D.A. & Hartman, H.B. (1975) Tension receptors

associated with the tailspine muscles of the Horseshoe crab, Limulus polyphemus. J. comp. Physiol. 101, 289-307.

- Easton, D.M. (1972) Autotomy of walking legs in the Pacific shore crab, Hemigrapsus oregonesis. Mar. Behav. Physiol. 1, 209-217.
- Edwards, R.L. (1958) Movements of individual members in a population of the shore crab, Carcinus maenas L., in the littoral zone. J. Anim. Ecol. 27, 37-45.
- Evoy, W.H. & Fournier, C.R. (1973) Nervous control of walking in the crab, Cardisoma guanhumi. III. Proprioceptive influences on intra- and inter-segmental coordination. J. comp. Physiol. 83, 303-318.
- Field, L.H. (1974) Sensory and reflex physiology underlying cheliped flexion behaviour in hermit crabs. J. comp. Physiol. 92, 397-414.
- Field, L.H. (1976) The effects of proprioceptive disruption on the motor program for cheliped flexion behaviour in hermit crabs. J. comp. Physiol. 105, 313-338.
- Fishelson, L. & Kidron, G. (1968) Experiments and observations on the histology and mechanism of autotomy and regeneration in Gena varia (Prosobranchia : Trochidae). J. Exp. Zool. 169, 93-106.
- Fredericq, L. (1883) Sur l'autotomie. Ou mutilation par voie reflexe comme moyen de defense chez les animaux. Arch. Zool. exp. gen. 2^e ser. 1, 413-426.

- Fredericq, L. (1892) Nouvelles recherches sur l'autotomie chez le crabe. Arch. Biol. 12, 169-197.
- Gomez, R. (1964) Autotomy and regeneration in the crab Paratelphusa hydrodromous. J. Anim. Morph. Physiol. 11, 97-104.
- Govind, C.K. & Lang, F. (1974) Neuromuscular analysis of closing in the dimorphic claws of the lobster Homarus americanus. J. Exp. Zool. 190, 281-304.
- Heitler, W.J. & Burrows, M. (1977) The locust jump. II. Neural circuits of the motor programme. J. exp. Biol. 66, 221-241.
- Hoadley, L. (1934) Autotomy in the anomuran Porcellana platycheles (Pennant). Biol. Bull. 67, 494-503.
- Hoadley, L. (1937) Autotomy in the brachyuran, Uca pugnax. Biol. Bull. 73, 155-163.
- Hoyle, G. & Burrows, M. (1973) Correlated physiological and ultrastructural studies on specialised muscles. IIIa. Neuromuscular physiology of the power-stroke muscle of the swimming leg of Portunus sanguinolentus. J. Exp. Zool. 185, 83-96.
- Iles, J.F. & Mulloney, B. (1971) Procion yellow staining of cockroach motor neurones without the use of microelectrodes. Brain Res. 30, 397-400.
- Jackson, H.G. (1913) Eupagurus! L.M.B.C. Memoirs No, 21. Williams & Norgate. London. pp. 79.

- Kater, S.B. & Nicholson, C. (Eds.) (1973) "Intracellular staining in neurobiology" Springer-Verlag. Berlin.
- Kater, S.B. & Rowell, C.H.F. (1973) Integration of sensory and centrally programmed components in the generation of cyclical feeding activity of Helisoma trivolis. J. Neurophysiol. 34, 142-155.
- King, H.D. (1898) Regeneration in Asterias vulgaris. Arch. EntwMeck. Org. 7, 351-363.
- King, H.D. (1900) Further studies on regeneration in Asterias vulgaris. Arch. EntwMech. Org. 9, 724-737.
- Kuris, A.M. & Mager, M. (1975) Effect of limb regeneration on size increase at moult of the shore crab Hemigrapsus oregonensis and Pachygrapsus crassipes. J. Exp. Zool. 193, 353-360.
- Layne, J.N. (1972) Tail autotomy in the Florida mouse, Peromyscus floridanus. J. Mammal. 53, 62-71.
- MacCulloch, J. (1825) On the means by which crabs throw off their claws. Q. J. Sci. Litt. Arts R. Inst. 20, 1-11.
- MacMillan, D.L. (1975) A physiological analysis of walking in the american lobster (Homarus americanus). Phil. Trans. R. Soc. B. 270, 1-59.
- MacMillan, D.L. & Dando, M.R. (1972) Tension receptors associated with the apodemes of muscles in the walking legs of the crab Cancer magister. Mar. Behav. Physiol. 1, 185-208.

- MacMillan, D.L., Wales, W. & Laverack, M.S. (1976)
Mandibular movements and their control in Homarus
gammarus. III. Effects of load changes.
J. comp. Physiol. 106, 207-221.
- Maiorana, V.C. (1977) Tail autotomy, functional conflicts
and their resolution by a salamander. Nature (Lond.)
265, 533-535.
- McVean, A.R. (1970) Neuromuscular co-ordination in Carcinus
maenas. Ph.D. Thesis, University of Wales, Cardiff,
Wales.
- McVean, A.R. (1973) Autotomy in Carcinus maenas (Decapoda :
Crustacea). J. Zool., Lond. 169, 349-364.
- McVean, A.R. (1974) The nervous control of autotomy in
Carcinus maenas. J. exp. Biol. 60, 423-436.
- McVean, A.R. (1975) Autotomy. Comp. Biochem. Physiol.
51A, 497-505.
- McVean, A.R. (1976) The incidence of autotomy in Carcinus
maenas L. J. exp. mar. Biol. Ecol. 24, 177-187.
- Moffett, S.B. (1973) The motor pattern of the basi-ischial
muscles in walking and autotomy in the land crab,
Cardisoma guanhumi. Ph.D. Thesis. University of
Miami, U.S.A.
- Moffett, S.B. (1975) Motor patterns and structural
interactions of basi-ischiopodite levator muscles
in routine limb elevation and production of autotomy

- in the land crab, Cardisoma guanhumi.
J. comp. Physiol. 96, 285-305.
- Moody, C.J. (1970) A proximally directed intersegmental reflex in a walking leg of the crayfish. Amer. Zool. 10, 501.
- Moody, C.J. (1972) Some aspects of the reflex organisation of a crustacean walking limb. Ph.D. Thesis, University of Miami, U.S.A.
- Morton, B. (1973) The biology and functional morphology of Galeomma (Paralepida) takii (Bivalvia : Leptonacea). J. Zool., Lond. 169, 133-150.
- Naylor, E. (1962) Seasonal changes in a population of Carcinus maenas (L.) in the littoral zone. J. Anim. Ecol. 31, 601-609.
- Needham, A.E. (1953) The incidence and adaptive value of autotomy and of regeneration in Crustacea. Proc. zool. Soc. Lond. 123, 111-122.
- Paul, J.H. (1914) Regeneration of the legs of Decapod Crustacea from the preformed breaking plane. Proc. Roy. Soc. (Edin.) B. 35, 78-94.
- Paul, J.H. (1915) A comparative study of the reflexes of autotomy in decapod Crustacea. Proc. Roy. Soc. (Edin.) B. 35, 232-262.
- Pearson, K.G. & Iles, J.F. (1973) Nervous mechanisms underlying intersegmental coordination of leg

- movements during walking in the cockroach.
J. exp. Biol. 58, 725-744.
- Pearson, K.G., Wong, R.K.S. & Fournier, C.R. (1976)
Connexions between hair-plate afferents and motoneurons
in the cockroach leg. J. exp. Biol. 64, 251-266.
- Pilgrim, R.L.C. (1973) Axial skeleton and musculature in
the thorax of the hermit crab, Pagurus bernhardus
(Anomura : Paguridae). J. mar. biol. Ass. U.K.
53, 363-396.
- Pitman, R.M., Tweedle, C.D. & Cohen, M.J. (1972)
Branching of central neurones : Intracellular cobalt
injection for light and electron microscopy.
Science 176, 412-414.
- Possompes, B. (1961) Structures et mecanismes lies a
l'autotomie chez les Phasmes. Le niveau d'autotomie.
C.R. Acad. Sci. Paris 253, 3089-3091.
- Pratt, C.W.M. (1946) The plane of fracture of the caudal
vertebrae of certain lacertilians. J. Anat. 80, 184-188.
- Raja, P.V., Ravindranath, M.H. & Ramalingam, K. (1976)
Studies on autotomy in Crustaceans. II. Changes
in hemolymph sugars of shore crab Ocypode platytarsis
in response to autotomy and bleeding stress.
Physiol. Zool. 49, 389-397.
- Richards, C.W. (1961) "Engineering materials science"
Chapman & Hall. London.

- Robinson, M.H., Abele, L.G. & Robinson, B. (1970)
Attack autotomy : a defense against predators.
Science 169, 300-301.
- Sandeman, D.C. (1969) The site of synaptic activity and
impulse initiation in an identified motoneurone in
the crab brain. J. exp. Biol. 50, 771-784.
- Shen, C.J. (1935) An investigation of the post-larval
development of the shore crab Carcinus maenas with
special reference to secondary sexual characters.
Proc. zool. Soc. Lond. 1, 1-33.
- Sheppard, L. & Bellairs, A. d'A. (1972) The mechanism of
autotomy in Lacerta. Br. J. Herpetol. 4, 276-286.
- Sherman, R.G. (1977) Comparative analysis of an excitatory
motor unit in Crustaceans. J. comp. Physiol. 144, 91-101.
- Smith, G.N. & Greenberg, M.J. (1973) Chemical control of
the evisceration process in Thyone briareas.
Biol. Bull. 144, 421-436.
- Strausfeld, N.J. & Obermayer, M. (1976) Resolution of
intraneuronal and transynaptic migration of cobalt
in the insect visual and central nervous systems.
J. comp. Physiol. 110, 1-12.
- Swann, E.F. (1966) Growth, autotomy and regeneration.
In "Physiology of Echinodermata" Booloottian, R.A. (Ed),
Interscience. New York. pp. 417-434.
- Tyrer, N.M. & Altman, J.S. (1974) Motor and sensory

- flight neurones in a locust demonstrated using cobalt chloride. J. comp. Neurol. 157, 117-138.
- Tyrer, N.M. & Bell, E.M. (1974) The intensification of cobalt-filled neurone profiles using a modification of Timm's sulphide-silver method. Brain Res. 73, 151-155.
- Vedel, J.P. & Clarac, F. (1975) Neurophysiological study of the antennal motor patterns in the rock lobster Palinurus vulgaris. II. Motoneuronal discharge patterns during passive and active flagellum movements. J. comp. Physiol. 102, 223-235.
- Vedel, J.P., Clarac, F. & Bush, B.M.H. (1975) Proximo-distal motor coordination in locomotor appendages of the rock lobster. C.R. Acad. Sci. Paris 281, 723-726.
- Wake, D.B. & Dresner, I.G. (1967) Functional anatomy and evolution of tail autotomy in salamanders. J. Morph. 122, 265-306.
- Wales, W., Clarac, F., Dando, M.R. & Laverack, M.S. (1970) Innervation of the receptors present at the various joints of the pereopods and third maxilliped of Homarus gammarus (L.) and other Macruran decapods (Crustacea). Z. vergl. Physiol. 68, 345-384.
- Wales, W., Clarac, F. & Laverack, M.S. (1971) Stress detection at the autotomy plane in the decapod Crustacea. I. Comparative anatomy of the receptors

- of the basi- ischiopodite region. Z. vergl. Physiol. 73, 357-382.
- Walne, P.R. (1976) Studies at Conwy on predation by the shore crab. Report, MAFF Fisheries Experiment Station, Conwy, Gwynedd.
- Warner, G.F. & Jones, A.R. (1976) Leverage and muscle type in crab chelae (Crustacea : Brachyura). J. Zool. 180, 57-68.
- Weis, J.S. (1976) Effects of environmental factors on regeneration and moulting in fiddler crabs. Biol. Bull. 150, 152-162.
- Whitear, M. (1962) The fine structure of crustacean proprioceptors. I. The chordotonal organs in the legs of the shore crab, Carcinus maenas. Phil. Trans. R. Soc. B. 245, 291-324.
- Wong, R.K.S. & Pearson, K.G. (1976) Properties of the trochanteral hair plate and its function in the control of walking in the cockroach. J. exp. Biol. 64, 233-249.
- Wood, F.D. & Wood, H.E. (1932) Autotomy in decapod Crustacea. J. Exp. Zool. 62, 1-55.